

# PRODUCT CATALOG

## Industrial Filters

SFN, SFL, SFM, SFS, SFB



### *We are 30*

*We were the first in the USSR to start the production of local exhaust ventilation systems for industrial companies. At the outset, most of our team consisted of young employees from the Occupational Health and Safety Institute.*

*We had to overcome many obstacles, including the collapse of the USSR, financial crises, market instability, and bureaucratic roadblocks. The company put its soul and efforts in the training of qualified personnel. We improved processes, expanded our production facilities, and opened new offices in Russia and abroad.*

*This helped us become leaders in this market segment in Russia. Over the years we have grown manifold in a professional, technological, industrial, and geographic sense. Today, our capabilities allow us to solve almost any problem in the area of industrial ventilation and air purification at the modern level and in compliance with international quality standards.*

*We achieved success in cooperation with many foreign partners, leaders of the global market, because initially our company had been established as a joint venture with an excellent Swedish company. We learned a lot from them, and we tried to adapt their experience and knowledge to the Russian environment. I would like to extend our special gratitude to our customers who have trusted us to handle their environmental and OH&S issues at their companies, and we did so, with their cooperation.*

*The result of 30 years of hard work are tens of thousands of successfully implemented projects, vast experience, professional knowledge, and high qualifications of our large team. These results multiply our strengths and make our progress natural and meaningful!!!*

Director General of  
SovPlym JSC  
A. M. Khanin





Yesterday... 1989

Today... 2019



SovPlym JSC production team



Production launch



SovPlym JSC production team

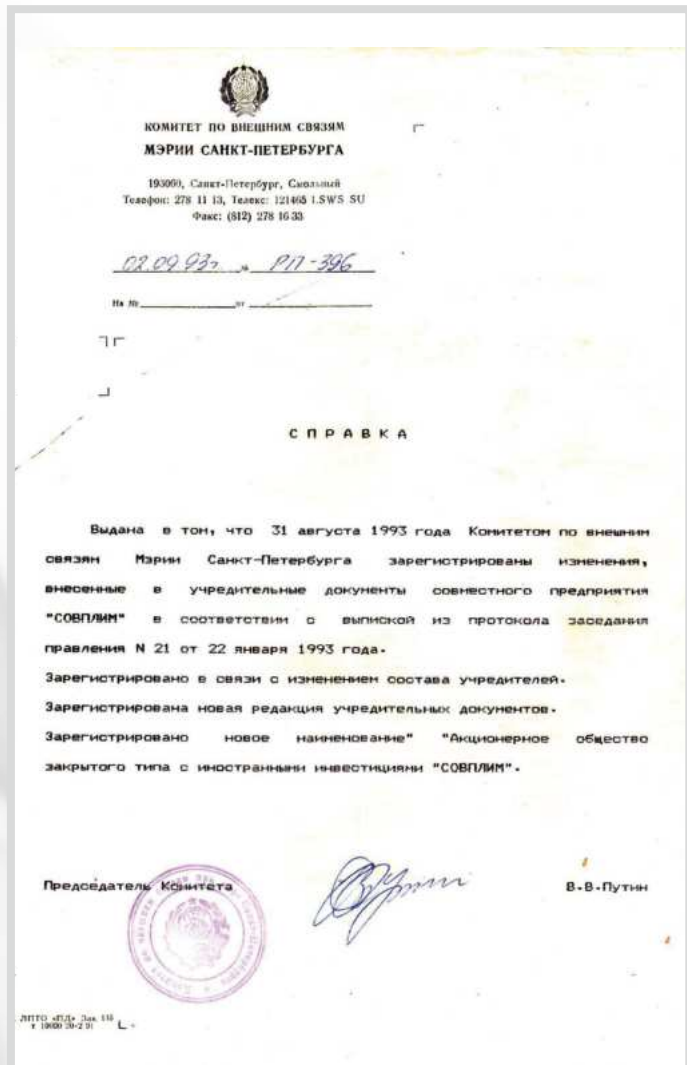

Signing a cooperation agreement

## The company was founded in 1989

SovPlym was the first company in Russia to start a series production of local exhaust ventilation systems for various production processes.

SovPlym was one of the first joint ventures with foreign investments in Leningrad.



Blank section



Paint section



Mechanical assembly section



Finished product warehouse



## Product development

## Facility design



Product is developed in **SolidWorks** 3D design framework using aerodynamic flow calculation module **Flow Simulation**.

Each product undergoes the following stages:

- 3D modeling;
- calculations of strength and aerodynamics;
- release of work design documentation;
- issuance of operational documentation;
- laboratory testing.

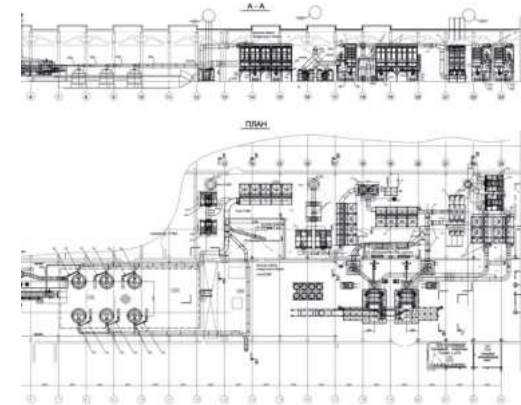
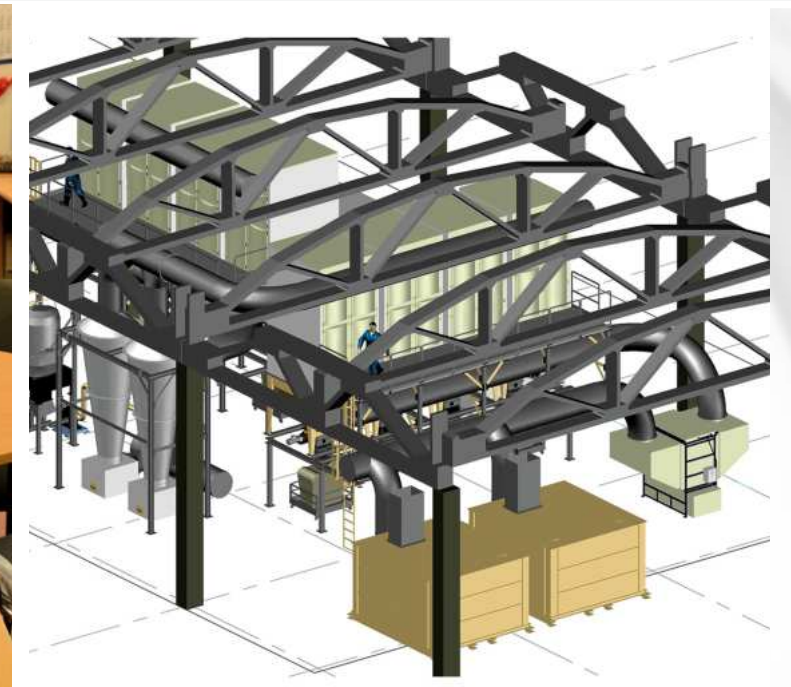

SOVPLYM JSC PERFORMS ALL SYSTEM DESIGN WORKS:

- ventilation;
- aspiration;
- dust extraction;
- dust and gas treatment.

1. PRE-DESIGN AUDIT:

- inspecting a facility;
- collecting input data;
- drafting a technical assignment.

2. DESIGN:

- development of design documentation outlining basic technical solutions;
- development of work documentation with basic sets of drawings and specifications of equipment, products and materials required for construction and installation works.

3. OBTAINING APPROVALS TO PASS EXPERT ASSESSMENTS

4. DESIGNER'S SUPERVISION

SovPlym JSC is a SRO member

SovPlym JSC specialists are listed in the national registry of the National Association of Researchers and Designers (NOPRIZ).

We use the following modeling software:





## Manufacturing capacities

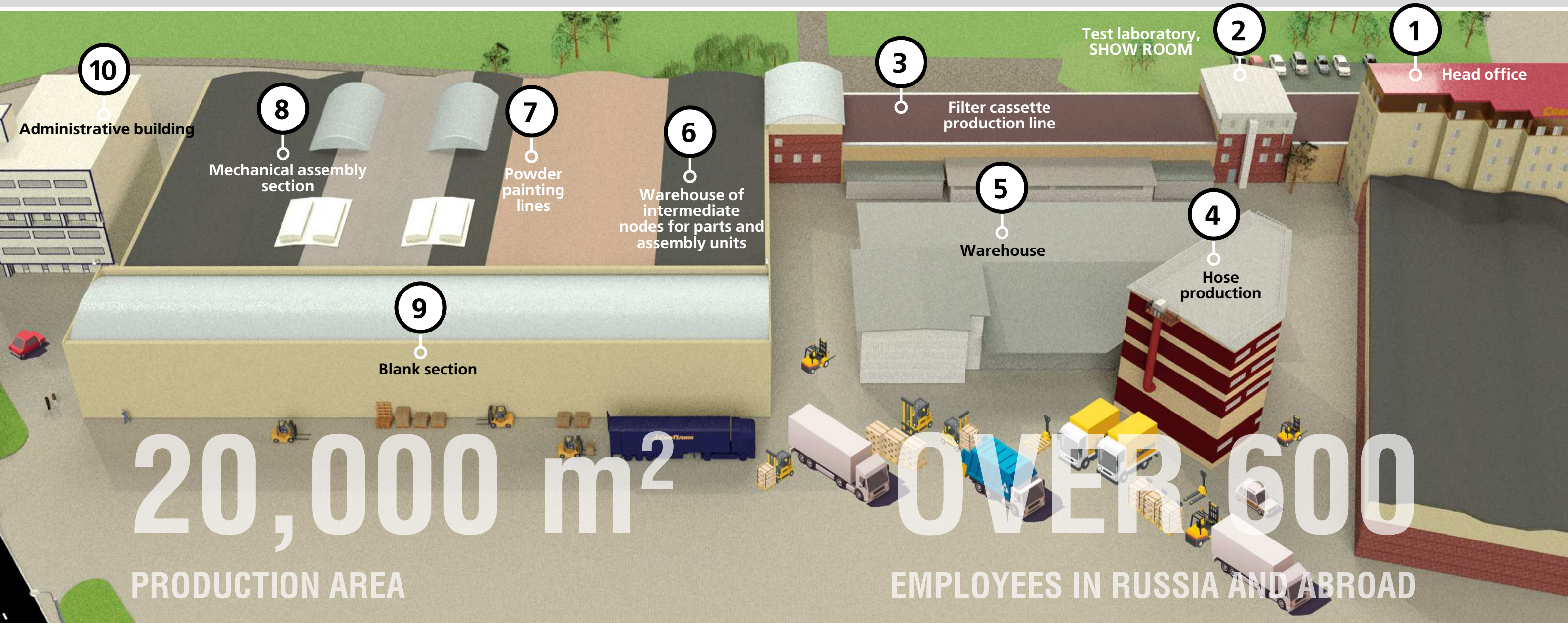

The blank production is based on machines made by Japanese company **AMADA**, the world-known leader in equipment manufacture for sheet metal processing. Laser cutting machines and a coordinate turntable press are used to make parts of a sheet up to 16 mm thick, with a processing precision of  $\pm 0.1$  mm, and high-quality surface. High-precision machines of well-known companies such as **Haco, Deka, and Finn Power** are used to chip, bend, and cut metal.

Welding equipment made by such companies as **Air Liquide Welding, WECO, and Kemppi** is used for welding, providing first-class weld joints, and only certified Western consumables are applied.

Three semi-automatic powder painting lines use paints of well-known Finnish company **Teknos** and Dutch company **AkzoNobel**, which provide reliable polymer coating, long-term service life, and good appearance of products.

Paint is sprayed by electrostatic method ensuring top-quality coating of basic parts. Coating pistols of Swiss company **Gemma** are used for spraying. These lines allow to paint products any color up to 7 m long.

There is strict incoming inspection of assemblies ordered and consumables used in the production. All manufactured products undergo regulatory tests for compliance with quality standards in own test laboratory.

**Production is based on international standards, the quality management system is certified for compliance with ISO 9001:2015.**



# Table of Contents

<b>1. ABOUT US</b>	3
<b>2. GENERAL DESCRIPTION</b>	12
<b>3. PURPOSE</b>	12
<b>4. APPLICATIONS</b>	12
<b>5. MODEL RANGE AND MARKING</b>	12
<b>6. SUMMARY SPECIFICATIONS</b>	13
<b>7. SFN SERIES FILTERS</b>	14
Description	14
Applications of SFN filters	15
Restrictions in the use of SFN filters	15
Design versions of SFN series filters	16
Filter elements of SFN series filters	16
Delivery set	18
Technical drawing of pocket filter SFN-36/..-GV/DB	19
Technical drawing of pocket filter SFN-54/..-GV/DB	20
Technical drawing of pocket filter SFN-72/..-GV/DB	21
Technical drawing of pocket filter SFN-90/..-GV/DB	22
Technical drawing of pocket filter SFN-108/..-GV/DB	23
Technical drawing of pocket filter SFN-126/..-GV/DB	24
Technical drawing of spot pocket filter SFN-FH	25
<b>8. SFL SERIES FILTERS</b>	26
Description	27
Applications of SFL filters	27
Restrictions in the use of SFL filters	27
Filter elements of SFL series filters	27
Design versions of SFL series filters	29
Delivery set	29
General technical drawing of filter SFL-36/..-GV/DB	31
General technical drawing of filter SFL-54.-GV/DB	32
General technical drawing of filter SFL-72.-GV/DB	33
General technical drawing of filter SFL-108W.-GV/DB	34
General technical drawing of filter SFL-108/..-GV/DB	35
General technical drawing of filter SFL-144/..-GV/DB	36
General technical drawing of filter SFL-162/..-GV/DB	37
General technical drawing of filter SFL-216/..-GV/DB	38
Example of alternative version of filter SFL-360/..-GV/DB.	39
General technical drawing of SFL spot (silo, pipelined) cartridge filter	40
Configuration of inlet/outlet flanges in SFN and SFL filters	41
<b>9. SFM SERIES FILTERS</b>	42
Description	43
Applications of SFM filters	43
Restrictions in the use of SFM filters	43
Filter elements of SFM series filters	43
Special features of SFM filter regeneration	44
Marking of SFM series filters	44
General technical drawing of SFM series filter	45
SFM-20 spot pressure filter	46
Delivery set	46
Drawing of SFM (silo, conveyor) filter	47

<b>10. SFS SERIES FILTERS</b>	48
Description	49
Applications of SFS filters	49
Restrictions in the use of SFS filters	49
Design versions of SFS series filters	50
Filter elements of SFS series filters	51
Marking of SFS series filters	52
SFS filter configurations in sets	53
Technical drawing of bag filter SFS-50 100	54
Technical drawing of bag filter SFS-75 150	55
Technical drawing of bag filter SFS-75 225	56
Technical drawing of bag filter SFS-75 450	57
Technical drawing of bag filter SFS-75 1800	58
<b>11. SFB SERIES FILTERS</b>	60
Description	61
Applications of SFB filters	61
Filter elements of SFB series filters	61
Restrictions in the use of SFB filters	62
Specifications of SFB series filters	62
Marking of SFB series filters	63
Versions of SFB filters	63
Delivery set	63
General technical drawing of SFB series filter	64
<b>12. ADDITIONAL FILTER DATA</b>	65
Compressed-air requirements	65
Pre-separator	65
Filter painting	65
Dust discharge methods	65
<b>13. FANS FOR SERIES FILTERS</b>	66
<b>14. FAN SPECIFICATIONS</b>	68
<b>15. CHECKLIST</b>	69

SFN, SFL,  
SFM, SFS, SFB

WWW.SOVPLYM.RU  
8 (800) 555-83-03





# Foreword

This catalog contains technical information on a new line of industrial filters manufactured by SovPlym JSC, which series production started in 2017. As part of piece production, the industrial filters presented in this catalog were first released at the end of 2015.

## 1. General Description

The model range is represented by a wide selection of self-cleaning filter units, both with regeneration by compressed-air pulse purge and mechanical stirring. Smooth pockets, flat pleated cartridges, and cylindrical cartridges are used as filter elements. On a case-by-case basis, a wide range of the most advanced filter materials provide optimal working conditions, with purification degree up to 99.99 %.

## 2. Purpose

The equipment is designed to clean air from dust of various types, namely: wood, textile, food, paper, glass, and coal. As well as construction dust, lime, chalk, gypsum, dolomite, cement, etc. Particle size of captured dust is from 0.1 microns.

### Filter Model Range

Model range marking		Brief equipment description
Short	Full	
SFN	SovPlym Filter Normal	Filter with flat smooth pockets on lattice frames, with pulse purge.
SFL	SovPlym Filter Lamellar	Filter with flat pleated cartridges, with pulse purge.
SFM	SovPlym Filter Mechanical	Filter with woven pockets on mesh frames, with mechanical stirring.
SFS	SovPlym Filter Sleeve	Bag filter with pulse purge.
SFB	SovPlym Filter Barrel	Filter with cylindrical pleated cartridges, with pulse purge.

## 3. Applications

Filters are used to clean air removed from workplaces and process equipment: crushers, screens, mills, conveyors, bunkers, barrels, etc. Applications: metallurgical, chemical, mining, processing, construction, and other production industries. Filter units are designed both for indoor and outdoor use in low ambient temperatures.

## 4. Filter Model Range and Marking

The model range consists of four types of filters described in the table below.

### Example of filter marking

## SFL-108/2-GV/DB-WP ant

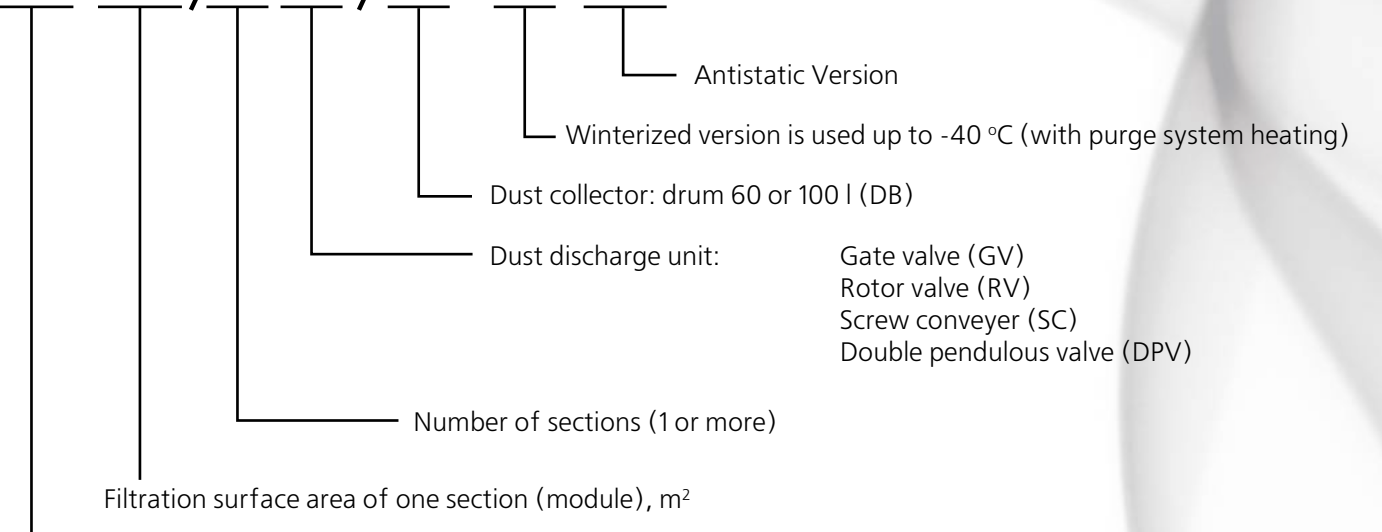

Model range: SFN, SFL, SFB, SFM, SFS

## 5. Summary Specifications

### Specifications of Filter Series

Parameter	Filter				
	SFN	SFL	SFB	SFM	SFS
Maximum capacity, m³/h	2,000–60,000	2,000–78,000	2,000	3,500	2,000,000
Permissible load (filtration rate), m³/m² min.	1.6	1.25	1.25	1.30	1.0–2.0
Filter resistance, operating/maximum, Pa	800–1200/2000				
Type of filter elements	Smooth pockets	Flat cartridges	Round cartridges	Smooth pockets	Cylindrical bags
Filter element regeneration method	Pulse purge			Mechanical stirring	Pulse purge
Maximum input dust concentration, g/m³	50		20		60
Standard residual dust concentration, mg/m³	<10–20	<10		<20	<20
Potential residual dust concentration, mg/m³	<0.01*		<1.0*	<0.1*	<0.01*
Maximum flow temperature, °C	80 (180*)	80		60	260
Minimum ambient temperature, °C	-20 -40*				
Operation mode	Continuous			Non-continuous	Continuous
Is antistatic version available?	Yes				

\* Non-series parameter (optional).

Technical characteristics and parameters of products listed in this catalogue may be changed without prior notice.



# SFN

Series



Filters with flat smooth pockets and pulse purge

# SFN Series Filters



## Description

SFN series filters represent versatile equipment used to perform various aspiration tasks in a wide range of processes. These are cost-effective, fully automatic self-cleaning modular continuous pocket filters with compressed-air pulse regeneration. Pockets are installed in one section horizontally, 12 pieces in a row, from 1 to 7 rows up. Filtration surface area of one module ranges from 18 to 126 m<sup>2</sup>. The filter is designed for continuous operation to clean air or gases from various types of dry loose, fibrous and slightly sticky dust, with an input concentration of up to 50 g/m<sup>3</sup>. The SFN filter is suitable for indoor and outdoor installations. Its modular design allows to achieve the required capacity by choosing the size and number of sections.

For dust discharge, the series uses containers for dust collection (drums of 60 and 100 l), equipped with manual cut-off valves to block the dust discharge point when the drum is removed from the running filter.

## Applications

- Aspiration of furnaces, cast houses
- Aspiration of silo and bunker loading/unloading
- Aspiration of process and associated equipment
- Aspiration of pouring sites, conveyor belts, conveyors, and elevators
- Aspiration of crushers, mills, screens, refrigerators, mixers, and dispensers
- Aspiration of thermal and mechanical metal cutting
- Aspiration of shot blasting and surface treatment
- Aspiration of welding processes

## Industries

- Chemical
- Metallurgical
- Metal working
- Mining
- Food
- Pharmaceutical
- Machine building
- Production of construction materials
- Cement production
- Other industries

## Restrictions in the use of SFN filters

(of series and piece production)

- Filters have no structural protection against explosion
- Not designed for the temperature of flow to be cleaned above 80 °C



Technical characteristics and parameters of products listed in this catalogue may be changed without prior notice.



## Filter Elements

Filter element for a SFN filter is a smooth pocket made of non-woven needle-punched material (such as fiber or sheet felt) stretched on a metal lattice frame (see the photo). The frame is fitted with an inlet reducer.

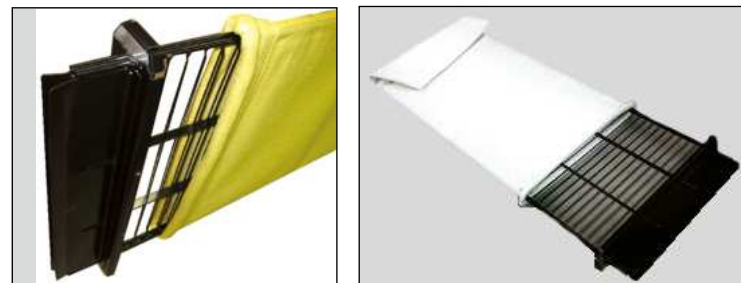

## Type of Filter Elements

Designation	Filtration surface, m <sup>2</sup>	Pocket material
PF-D-1.5-SFN	1.5	Polyester
PF-C-1.5-SFN		Antistatic polyester
PF-T-1.5-SFN		Teflon
PF-TC-1.5-SFN		Antistatic Teflon
PF-H-1.5-SFN		Water-repellent
PF-HC-1.5-SFN		Water-repellent antistatic
PF-A-1.5-SFN		Aramid (heat-resistant)
PF-AC-1.5-SFN		Antistatic aramid (heat-resistant)

## Design Versions of SFN Series Filters

SFN filters consist of a body divided into “clean” and “dirty” areas, a pyramidal dust collector, supports and a dust collection container with a manual cut-off gate. The filters are equipped with a compressed-air pulse purge system. Following are possible filter configurations, relevant filtration areas, and rated capacities.

## Summary Specifications of SFN Series Filters

Filter	Filtration area, m <sup>2</sup>	Capacity at a rated load, m <sup>3</sup> /h	Number of pockets in a filter, pcs.			Compressed-air flowrate, nm <sup>3</sup> /h	Weight, kg
			Horizontally	Vertically	General		
SFN-36/1	36	3,500	12	2	24	12	1,160
SFN-36/2	72	7,000	24	2	48	24	1,960
SFN-36/3	108	10,500	36	2	72	36	2,760
SFN-36/4	144	14,000	48	2	96	48	3,560
SFN-54/1	54	5,200	12	3	36	12	1,410
SFN-54/2	108	10,400	24	3	72	24	2,390
SFN-54/3	162	15,600	36	3	108	36	3,370
SFN-54/4	216	21,800	48	3	144	48	4,350
SFN-72/1	72	7,000	12	4	48	12	1,610
SFN-72/2	144	14,000	24	4	96	24	2,760
SFN-72/3	216	21,000	36	4	144	36	3,910
SFN-72/4	288	28,000	48	4	192	48	5,060
SFN-90/1	90	8,650	12	5	60	14	1,960
SFN-90/2	180	17,300	24	5	120	28	3,310
SFN-90/3	270	25,950	36	5	180	42	4,660
SFN-90/4	360	34,600	48	5	240	56	6,010
SFN-108/1	108	10,500	12	6	72	16	2,210
SFN-108/2	216	21,000	24	6	144	32	3,760
SFN-108/3	324	31,500	36	6	216	48	5,310
SFN-108/4	432	42,000	48	6	288	64	6,860
SFN-126/1	126	12,000	12	7	84	18	2,410
SFN-126/2	252	24,000	24	7	168	36	4,210
SFN-126/3	378	36,000	36	7	252	54	6,010
SFN-126/4	504	48,000	48	7	336	72	7,810

# SFN Series Filters

## Configurations available

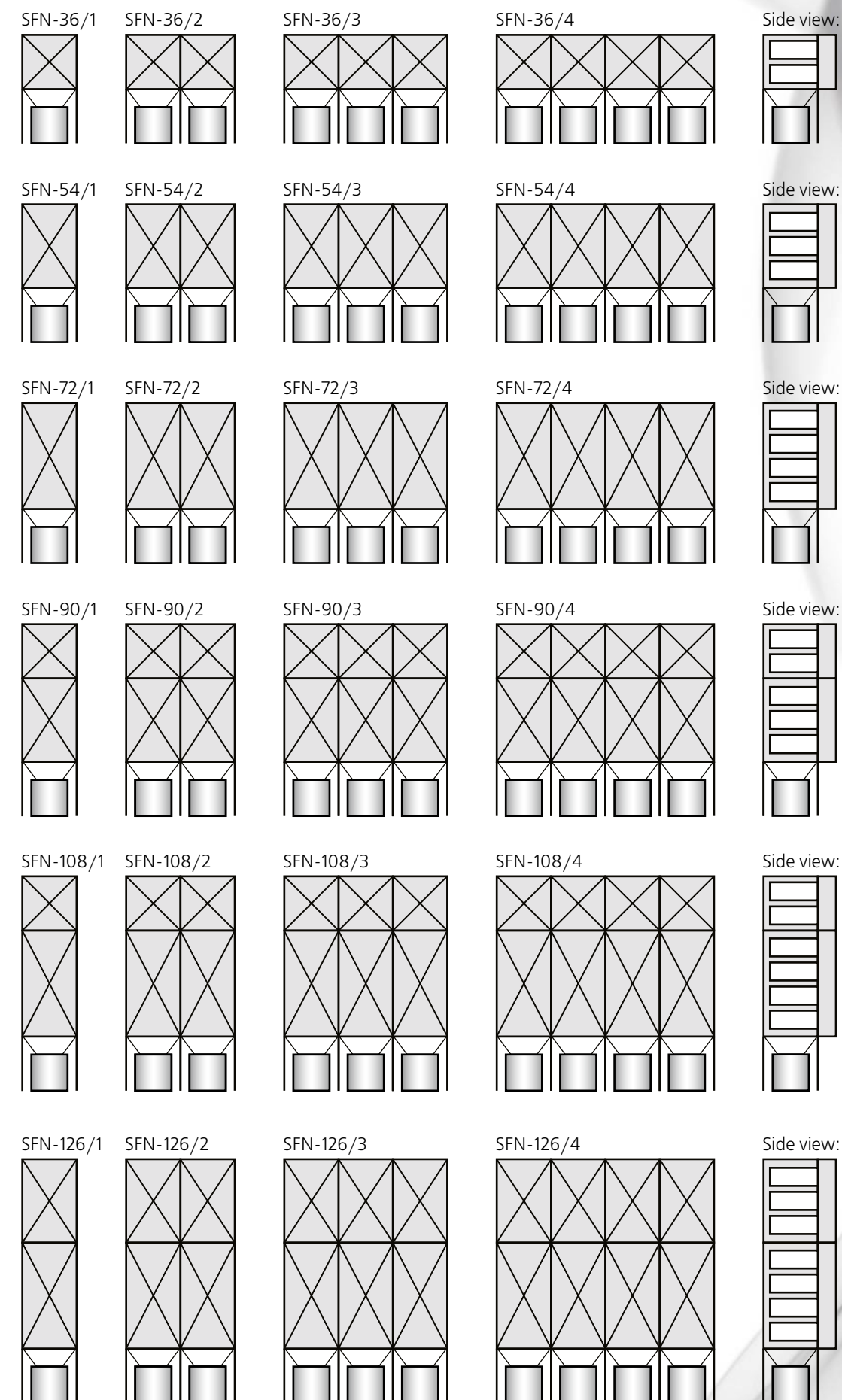



Series delivery set	
Filter body (dirty and clean areas)	
Gas inlet/outlet flanges on top (standard)	
Purge system included:	<ul style="list-style-type: none"> <li>– compressed-air receiver</li> <li>– purge pipes</li> <li>– pulse valves</li> </ul>
	<ul style="list-style-type: none"> <li>– KF-3 control unit (CONT-S)</li> <li>– differential pressure sensor</li> <li>– pre-separator with reducing gear</li> </ul>
Access doors	
Inspection hatch on the rear wall (by the number of sections)	
Filter pockets PF-D-1.5-SFN or PF-C-1.5-SFN	
Filter frames (painted)	
Pyramidal bunker (by the number of sections)	
Supports	
Manual cut-off gate valve (by the number of sections)	
Dust collector of 60 or 100 l (by the number of sections)	
Earthing line (for antistatic filters)	
Filter Painting	

Additional configuration	
Purge system heating included:	<ul style="list-style-type: none"> <li>– heat-insulated box (by the number of sections)</li> <li>– heating with thermostat (by the number of sections)</li> </ul>
Specific filter pockets	
Galvanized/stainless steel filter frames	
Body heat insulation	
Bunker heat insulation	
3-layer anti-corrosion treatment of body and dust collector	
Bunker heating	
Combined bunker	
Alternative dust discharge devices:	<ul style="list-style-type: none"> <li>– rotary valve (lock feeder)</li> <li>– double pendulous valve (flasher)</li> <li>– screw conveyor (for combined dust collector)</li> </ul>
	<ul style="list-style-type: none"> <li>– level sensor (in dust collector)</li> <li>– rotation sensor (for screw conveyor and rotary valve actuators)</li> <li>– compressed-air pressure control sensor</li> </ul>
Control sensors:	
Body-mounted fan	
Control and monitoring cabinet (under additional technical assignment)	



## General technical drawing of pocket filter SFN-36/..-GV/DB

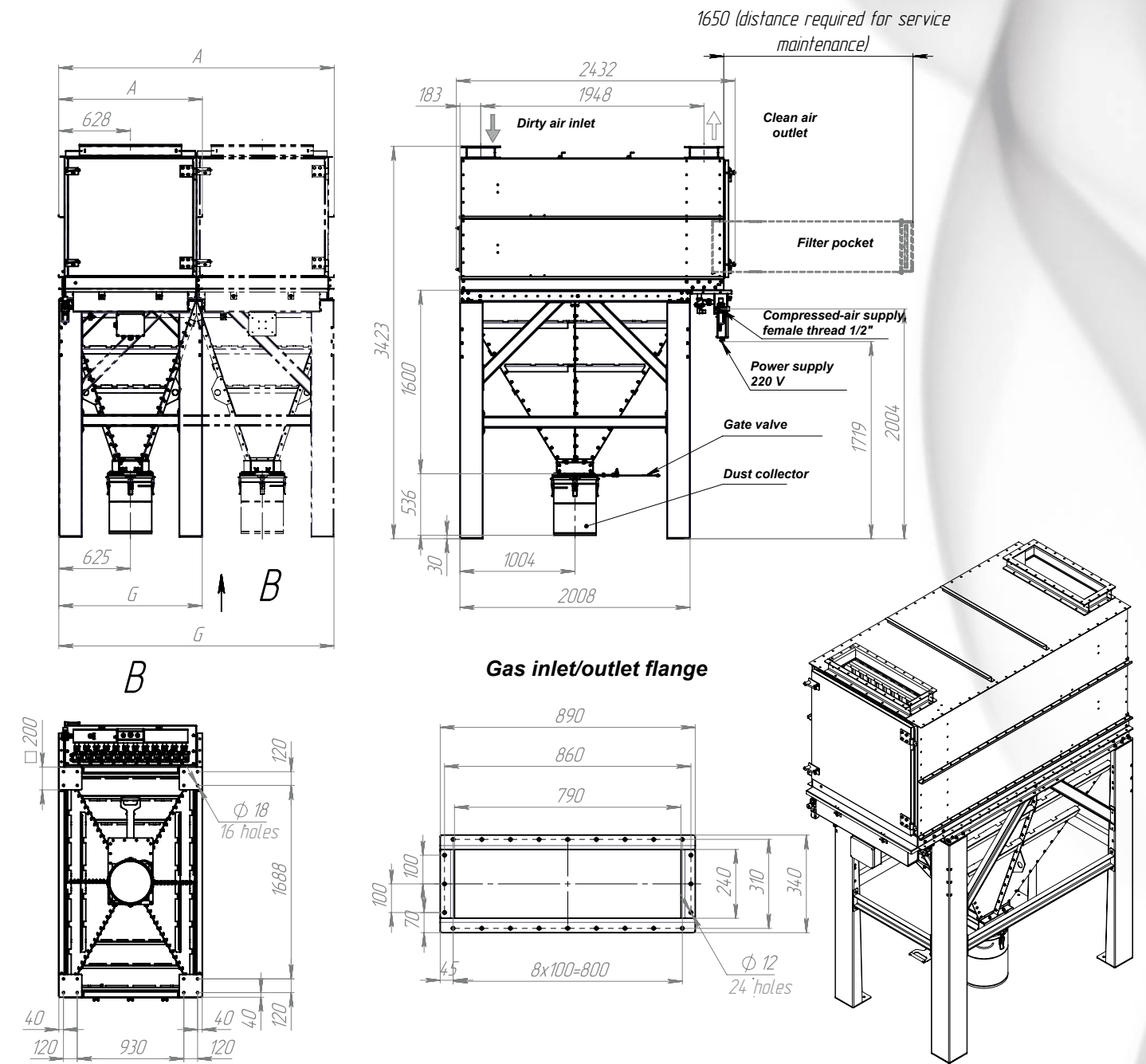

## Dimensions and specifications of SFN-36/.. series filters

Filter type	Capacity, m <sup>3</sup> /h	Filtration surface area, m <sup>2</sup>	Compressed-air flowrate, nm <sup>3</sup> /h	Number of pockets, pcs.	Weight, kg	A, mm	G, mm
SFN-36/1	3,500	36	12	24	1,160	1,255	1,250
SFN-36/2	7,000	72	24	48	1,960	2,405	2,400
SFN-36/3	10,500	108	36	72	2,760	3,555	3,350
SFN-36/4	14,000	144	48	96	3,560	4,705	4,700

A standard filter is equipped with a manual cut-off gate valve and a drum.

Technical characteristics and parameters of products listed in this catalogue may be changed without prior notice.



## General technical drawing of pocket filter SFN-54/..-GV/DB

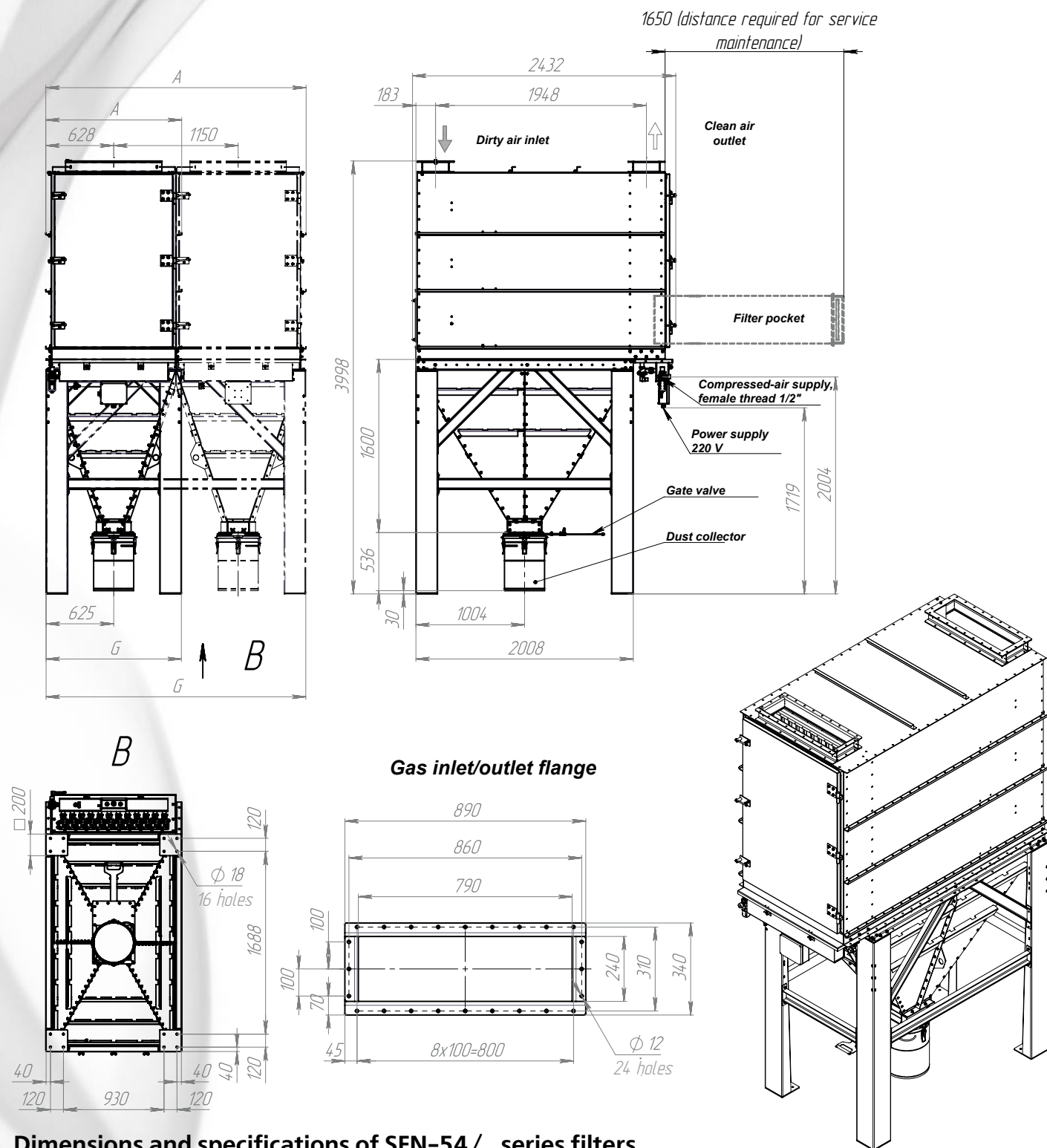

Dimensions and specifications of SFN-54/.. series filters

Filter type	Capacity, m <sup>3</sup> /h	Filtration surface area, m <sup>2</sup>	Compressed-air flowrate, nm <sup>3</sup> /h	Number of pockets, pcs.	Weight, kg	A, mm	G, mm
SFN-54/1	5,200	54	12	36	1,410	1,255	1,250
SFN-54/2	10,400	108	24	72	2,390	2,405	2,400
SFN-54/3	15,600	162	36	108	3,370	3,555	3,350
SFN-54/4	21,800	216	48	144	4,350	4,705	4,700

A standard filter is equipped with a manual cut-off gate valve and a drum.  
 Technical characteristics and parameters of products listed in this catalogue may be changed without prior notice.

## General technical drawing of pocket filter SFN-72/..-GV/DB

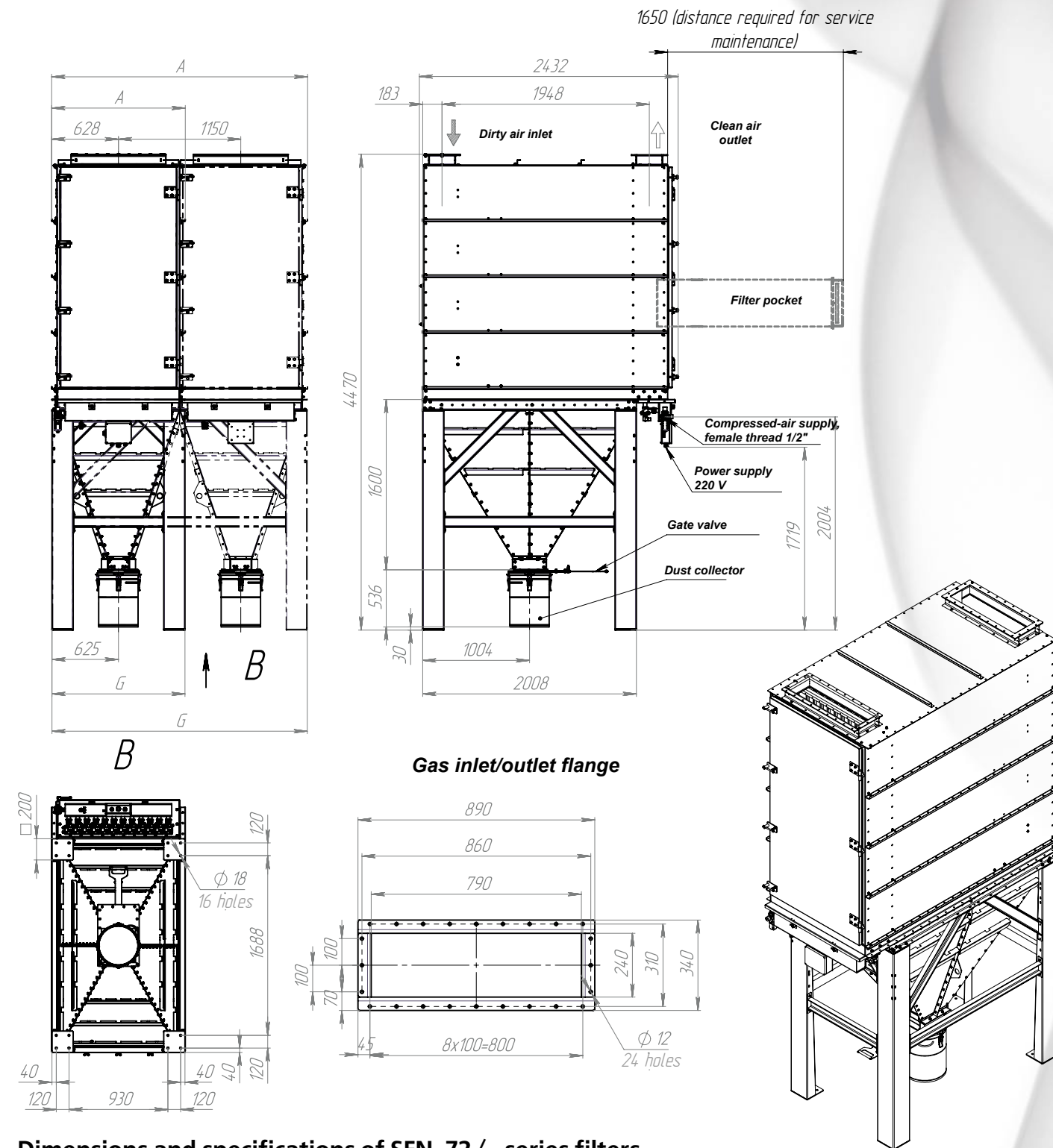

Dimensions and specifications of SFN-72/.. series filters

Filter type	Capacity, m <sup>3</sup> /h	Filtration surface area, m <sup>2</sup>	Compressed-air flowrate, nm <sup>3</sup> /h	Number of pockets, pcs.	Weight, kg	A, mm	G, mm
SFN-72/1	7,000	72	12	48	1,610	1,255	1,250
SFN-72/2	14,000	144	24	96	2,760	2,405	2,400
SFN-72/3	21,000	216	36	144	3,910	3,555	3,350
SFN-72/4	28,000	288	48	192	5,060	4,705	4,700

A standard filter is equipped with a manual cut-off gate valve and a drum.  
 Technical characteristics and parameters of products listed in this catalogue may be changed without prior notice.



## General technical drawing of pocket filter SFN-90/..-GV/DB

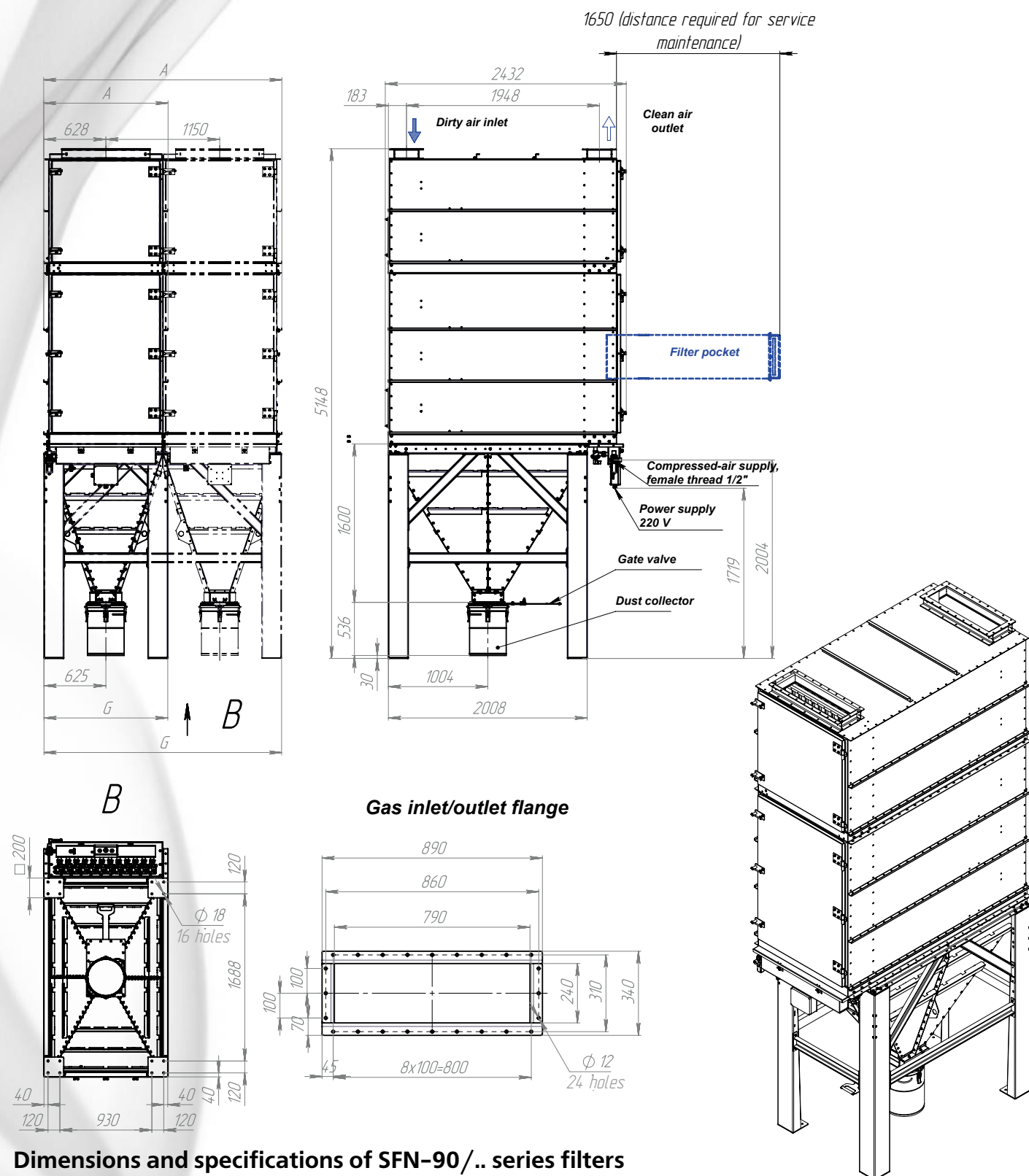

Dimensions and specifications of SFN-90/.. series filters

Filter type	Capacity, m <sup>3</sup> /h	Filtration surface area, m <sup>2</sup>	Compressed-air flowrate, nm <sup>3</sup> /h	Number of pockets, pcs.	Weight, kg	A, mm	G, mm
SFN-90/1	8,650	90	14	60	1,960	1,255	1,250
SFN-90/2	17,300	180	28	120	3,310	2,405	2,400
SFN-90/3	25,950	270	42	180	4,660	3,555	3,350
SFN-90/4	34,600	360	56	240	6,010	4,705	4,700

## General technical drawing of pocket filter SFN-108/..-GV/DB

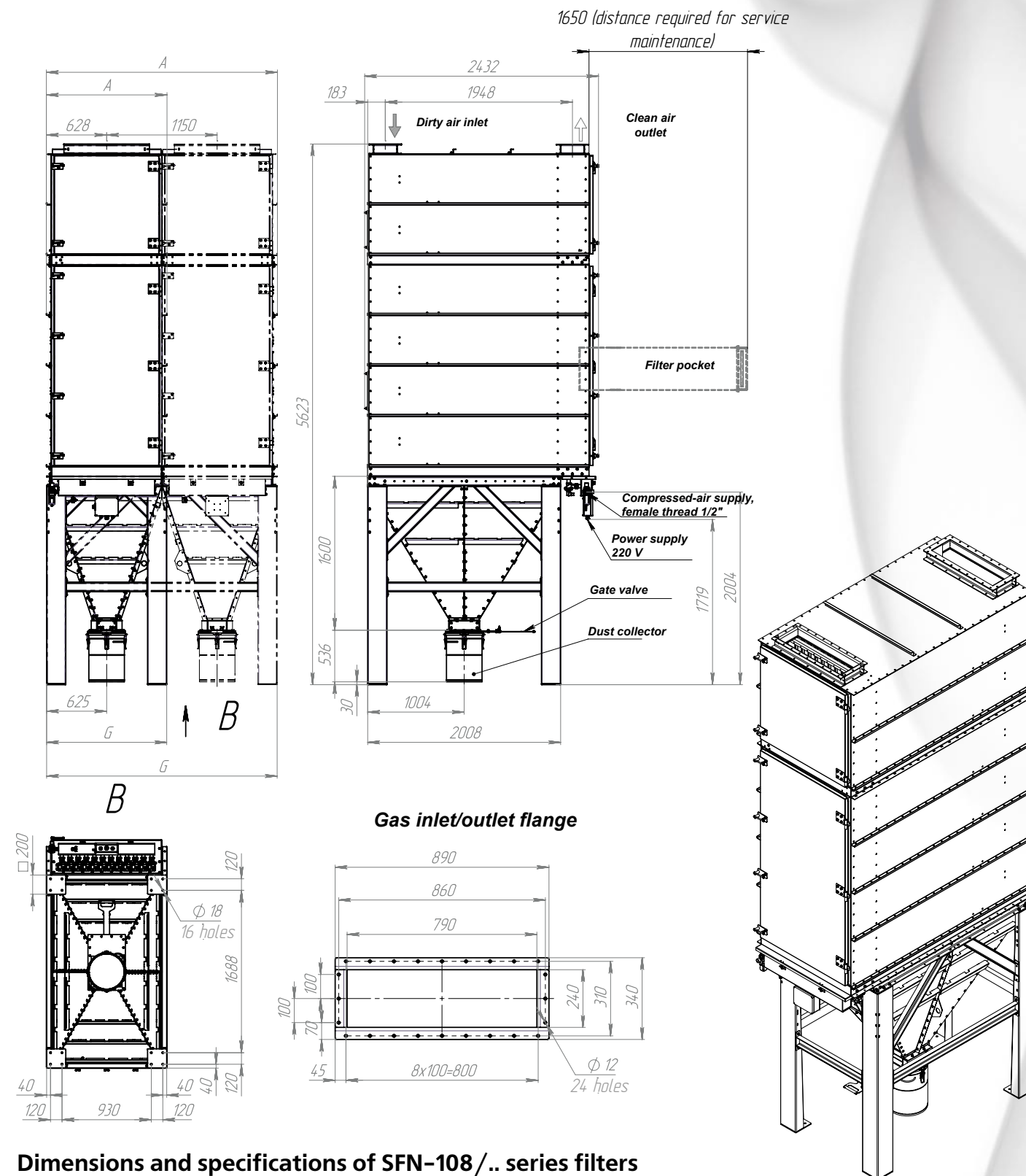

Dimensions and specifications of SFN-108/.. series filters

Filter type	Capacity, m <sup>3</sup> /h	Filtration surface area, m <sup>2</sup>	Compressed-air flowrate, nm <sup>3</sup> /h	Number of pockets, pcs.	Weight, kg	A, mm	G, mm
SFN-108/1	10,500	108	16	72	2,210	1,255	1,250
SFN-108/2	21,000	216	32	144	3,760	2,405	2,400
SFN-108/3	31,500	324	48	216	5,310	3,555	3,350
SFN-108/4	42,000	432	64	288	6,860	4,705	4,700



## General technical drawing of pocket filter SFN-126/..-GV/DB

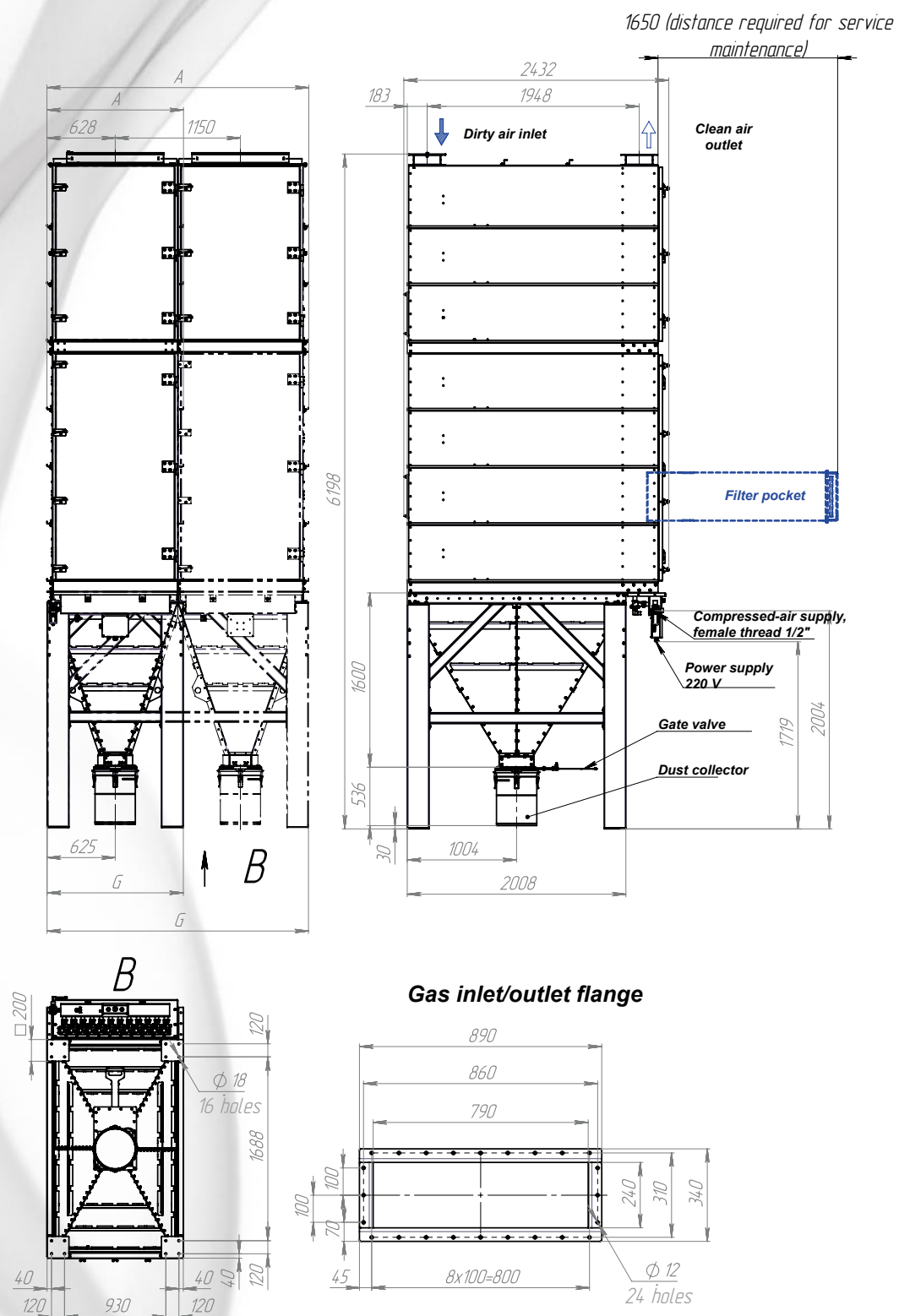

### Dimensions and specifications of SFN-126/.. series filters

Filter type	Capacity, m <sup>3</sup> /h	Filtration surface area, m <sup>2</sup>	Compressed-air flowrate, nm <sup>3</sup> /h	Number of pockets, pcs.	Weight, kg	A, mm	G, mm
SFN-126/1	12,000	126	18	84	2,410	1,255	1,250
SFN-126/2	24,000	252	36	168	4,210	2,405	2,400
SFN-126/3	36,000	378	54	252	6,010	3,555	3,350
SFN-126/4	48,000	504	72	336	7,810	4,705	4,700

A standard filter is equipped with a manual cut-off gate valve and a drum.  
 24 Technical characteristics and parameters of products listed in this catalogue may be changed without prior notice.

## General technical drawing of SFN-FH spot (conveyor, bunker, silo) pocket filter

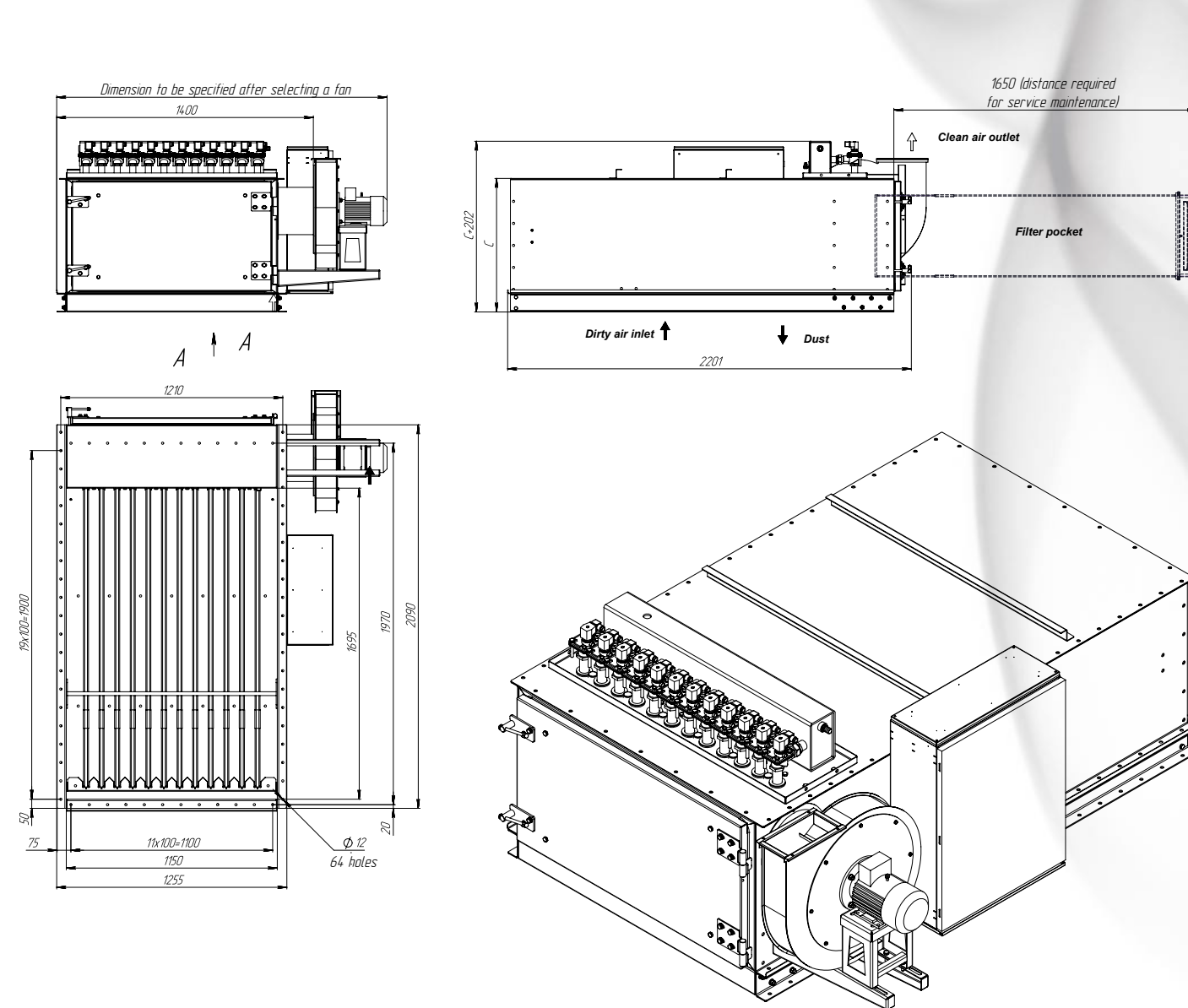

### SFN-FH Filters

SFN spot filters are manufactured both in a pressure version (without a fan) to ventilate pressurized silos, bunkers, etc. and in a negative-pressure version (with a fan) to be installed at pouring sites and silos, which require negative pressure.

### Dimensions and specifications of SFN-..-FH series bunker filters

Filter type	Capacity, m <sup>3</sup> /h	Filtration surface area, m <sup>2</sup>	Compressed-air flowrate, nm <sup>3</sup> /h	Number of pockets, pcs.	Weight, kg	C, mm
SFN-18-FH	1,800	18	18	12	450	728
SFN-36-FH	3,600	36	18	24	670	1,253
SFN-54-FH	5,400	54	18	36	890	1,778
SFN-72-FH	7,200	72	18	48	1,110	2,303

Technical characteristics and parameters of products listed in this catalogue may be changed without prior notice.



# SFL

Series



Filters with flat pleated cartridges and pulse purge

# SFL Series Filters



## Description

SFL filters are versatile, cost-effective, fully automatic self-cleaning modular continuous filters with compressed-air pulse regeneration. Flat pleated cartridges are used as filter elements. Cartridges are installed horizontally, 6 and 9 pieces in a row, from 1 to 4 rows up. Filtration surface area of one module ranges from 36 to 216 m<sup>2</sup>. The filter is designed for continuous operation to clean air or gases from various types of dry loose dust, with an input concentration of up to 50 g/m<sup>3</sup>. The SFL filter is suitable for indoor and outdoor installations.

Its modular design allows to achieve the required capacity by choosing the size and number of sections.

For dust discharge, the series uses containers for dust collection (drums of 60 and 100 l), equipped with manual cut-off valves to block the discharge point when the drum is removed from the running filter.

## Applications

- Aspiration of process and associated equipment
- Aspiration of pouring sites, conveyor belts, conveyors, and elevators
- Aspiration of crushers, mills, screens, refrigerators, mixers, and dispensers
- Aspiration of thermal and mechanical metal cutting
- Aspiration of shot blasting and surface treatment
- Aspiration of welding processes

## Restrictions in the use of SFL filters

(of series and piece production)

SFL series filters are not intended for the following types of dust:

- for smoldering and self-igniting dust;
- for fibrous dust;
- for sticky dust;
- for dust with a moisture content of more than 5 %;
- for cleaning air with temperatures above 80 °C.

## Industries

- Chemical
- Metallurgical
- Metal working
- Mining
- Food
- Pharmaceutical
- Machine building
- Production of construction materials
- Cement production
- Other industries

## Filter Elements

Filter element of a SFL filter is a flat pleated non-woven cartridge.



## Type of Filter Elements

Description	Filtration surface, m <sup>2</sup>	Pocket material
CART-D-SFL	6.0	Polyester
CART-C-SFL		Antistatic polyester
CART-T-SFL		Teflon (diaphragm)
CART-TC-SFL		Antistatic Teflon (diaphragm)



## Summary Specifications of SFL Series Filters

Filter	Filtration area, m <sup>2</sup>	Capacity at a rated load, m <sup>3</sup> /h	Number of cartridges in a filter, pcs.			Compressed-air flowrate, nm <sup>3</sup> /h	Weight, kg
			Horizontally	Vertically	General		
SFL-36/1	36	2,700	6	1	6	20	750
SFL-36/2	72	5,400	12	1	12	20	1,340
SFL-36/3	108	8,100	18	1	18	20	1,930
SFL-36/4	144	10,800	24	1	24	20	2,520
SFL-54/1	54	4,050	9	1	9	30	920
SFL-54/2	108	8,100	18	1	18	30	1,680
SFL-54/3	162	12,150	27	1	27	60	2,440
SFL-54/4	216	16,200	36	1	36	60	3,200
SFL-72/1	72	5,400	6	2	12	20	1,070
SFL-72/2	144	10,800	12	2	24	20	1,920
SFL-72/3	216	16,200	18	2	36	40	2,770
SFL-72/4	288	21,600	24	2	48	40	3,620
SFL-108W/1	108	8,100	9	2	18	30	1,340
SFL-108W/2	216	16,200	18	2	36	60	2,460
SFL-108W/3	324	24,300	27	2	54	90	3,580
SFL-108W/4	432	32,400	36	2	72	120	4,700
SFL-108/1	108	8,100	6	3	18	20	1,380
SFL-108/2	216	16,200	12	3	36	20	2,480
SFL-108/3	324	24,300	18	3	54	40	3,580
SFL-108/4	432	32,400	24	3	72	40	4,680
SFL-144/1	144	10,800	6	4	24	20	1,670
SFL-144/2	288	21,600	12	4	48	20	3,000
SFL-144/3	432	32,400	18	4	72	40	4,330
SFL-144/4	576	43,200	24	4	96	40	5,660
SFL-162/1	162	12,150	9	3	27	30	1,750
SFL-162/2	324	24,300	18	3	54	60	3,220
SFL-162/3	486	36,450	27	3	81	90	4,690
SFL-162/4	648	48,600	36	3	108	120	6,160
SFL-216/1	216	16,200	9	4	36	30	2,170
SFL-216/2	432	32,400	18	4	72	60	3,660
SFL-216/3	648	48,600	27	4	108	90	5,490
SFL-216/4	864	64,800	36	4	144	120	7,320
SFL-360/1	360	27,000	6+9	4	60	50	3,700

## Design Versions of SFL Series Filters

SFL filters consist of a body divided into “clean” and “dirty” areas, a pyramidal dust collector, supports and a dust collection container with a manual cut-off butterfly valve. The filters are equipped with a compressed-air pulse purge system. Following are possible filter configurations, relevant filtration areas, and rated capacities.

Standard delivery set	Additional configuration
Filter body (dirty and clean areas)	Purge system heating included: <ul style="list-style-type: none"> <li>– heat-insulated box (by the number of sections)</li> <li>– heating with thermostat (by the number of sections)</li> </ul>
Gas inlet/outlet flanges on top (standard)	
Purge system included: <ul style="list-style-type: none"> <li>– compressed-air receiver</li> <li>– purge pipes</li> <li>– control valves</li> <li>– KF-3 control unit (CONT-S)</li> <li>– differential pressure sensor</li> <li>– pre-separator with reducing gear</li> </ul>	Specific filter cartridges
Access doors	Body heat insulation
Inspection hatch on the rear wall (by the number of sections)	Bunker heat insulation
CART-D-SFL or CART-C-SFL filter cartridges	3-layer anti-corrosion treatment of body and dust collector
Pyramidal bunker (by the number of sections)	Bunker heating
Supports	Combined bunker
Manual cut-off gate valve (by the number of sections)	Alternative dust discharge devices: <ul style="list-style-type: none"> <li>– rotary valve (lock feeder)</li> <li>– double pendulous valve (flasher)</li> <li>– screw conveyer</li> </ul>
Dust collector of 60 or 100 l (by the number of sections)	
Earthing line (for antistatic filters)	Control sensors: <ul style="list-style-type: none"> <li>– level sensor (in dust collector)</li> <li>– rotation sensor (for screw conveyer and rotary valve actuators)</li> <li>– compressed-air pressure control sensor</li> </ul>
Filter Painting	Body-mounted fan
	Control and monitoring cabinet (under additional technical assignment)

## SFL Series Filters

### Configurations available

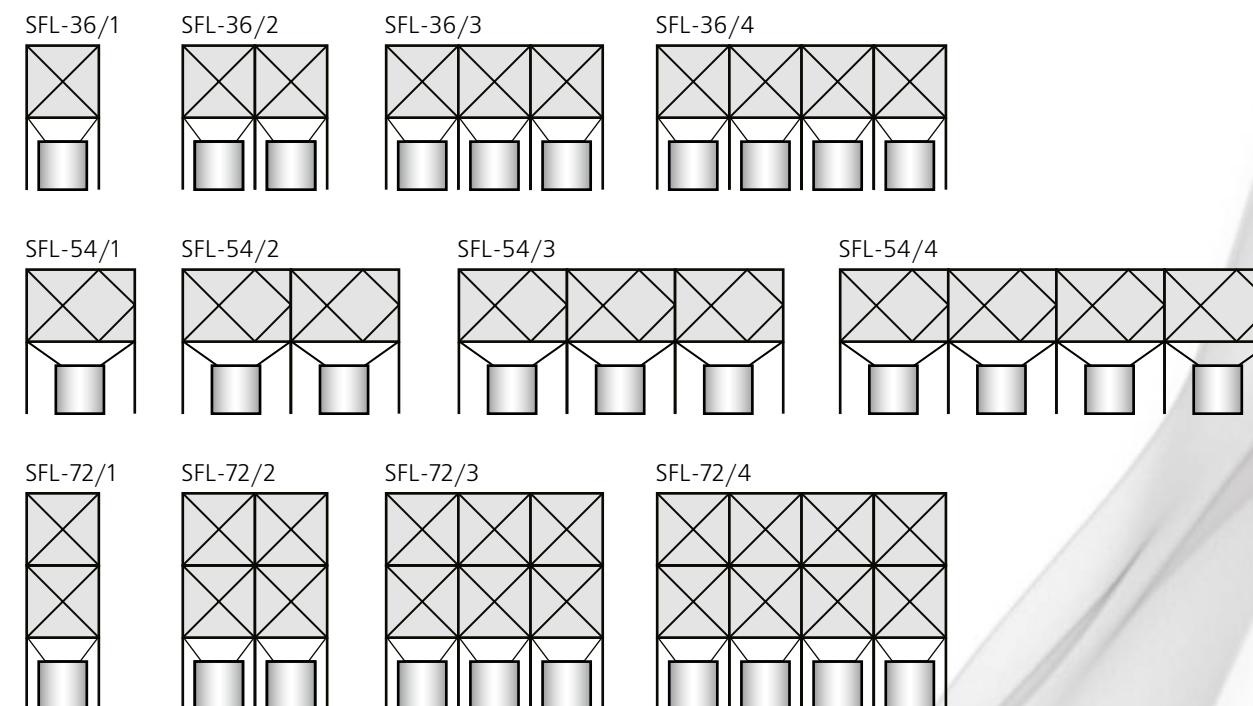



# SFL Series Filters

Configurations available

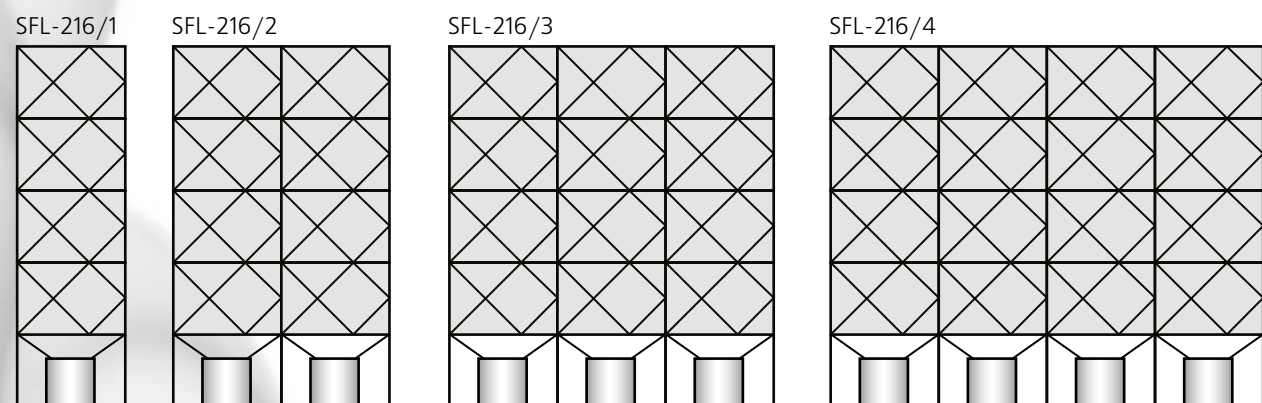
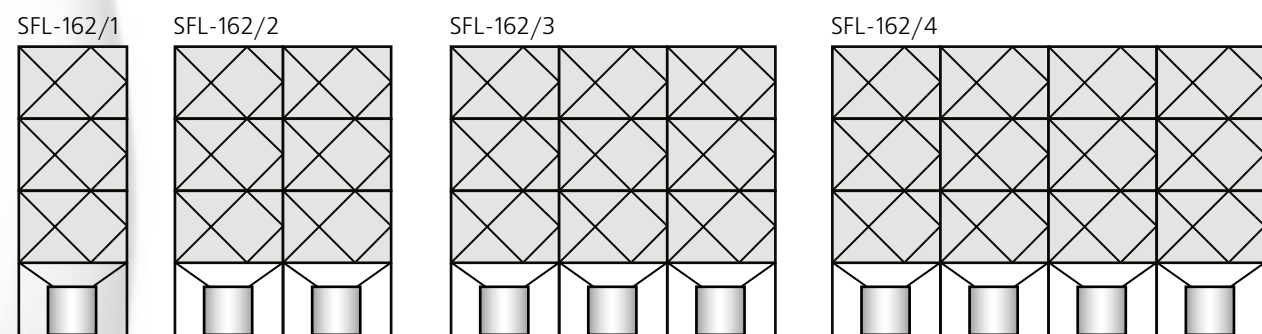
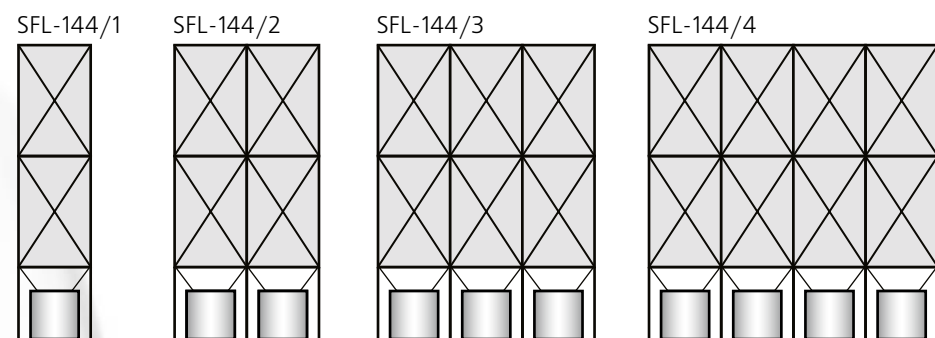
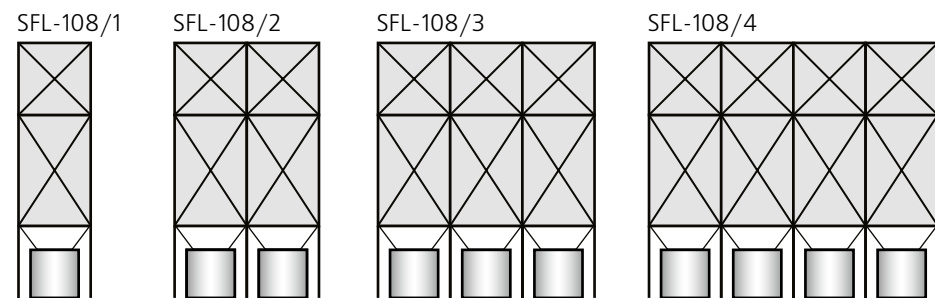
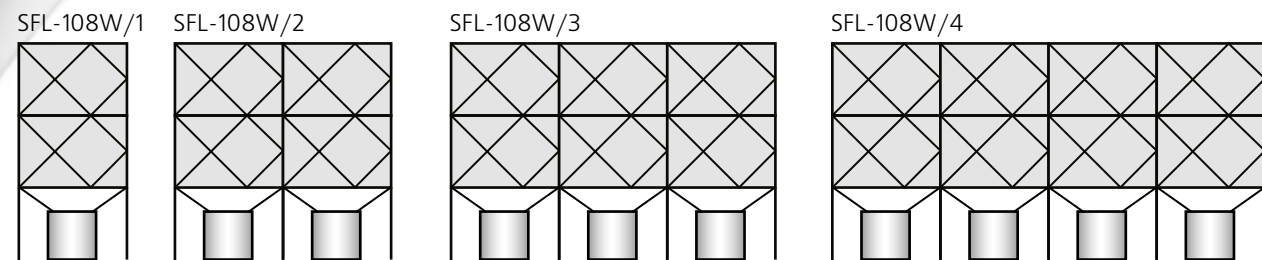

## General technical drawing of cartridge filter SFL-36/..-GV/DB

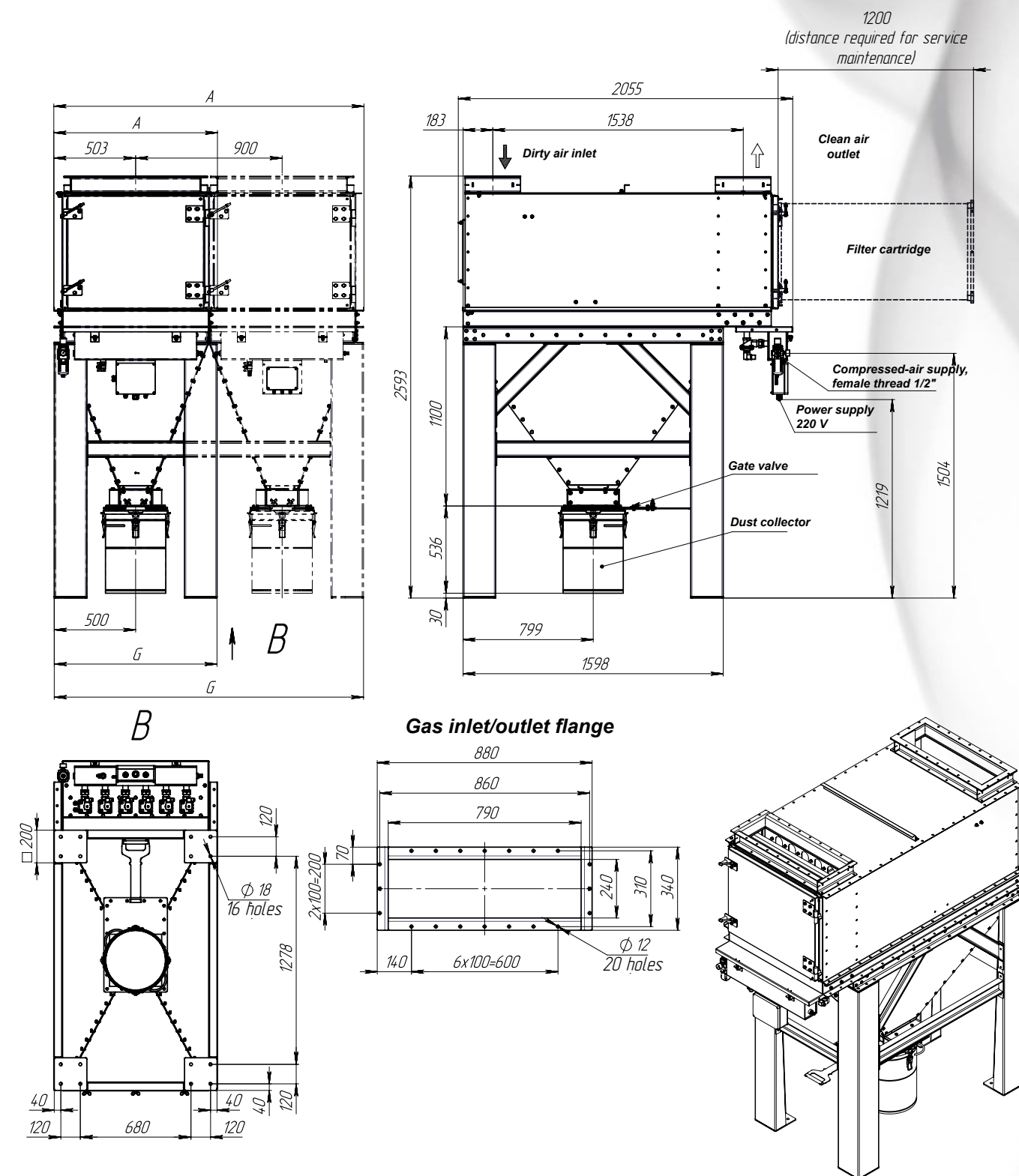

### Dimensions and specifications of SFL-36/.. series filters

Filter type	Capacity, m <sup>3</sup> /h	Filtration surface area, m <sup>2</sup>	Compressed-air flowrate, nm <sup>3</sup> /h	Number of cartridges, pcs.	Weight, kg	A, mm	G, mm
SFL-36/1	2,700	36	20	6	750	1,005	1,000
SFL-36/2	5,400	72	20	12	1,340	1,905	1,900
SFL-36/3	8,100	108	20	18	1,930	2,805	2,800
SFL-36/4	10,800	144	20	24	2,520	3,705	3,700

A standard filter is equipped with a manual cut-off gate valve and a drum.

Technical characteristics and parameters of products listed in this catalogue may be changed without prior notice.



## General technical drawing of cartridge filter SFL-54/..-GV/DB

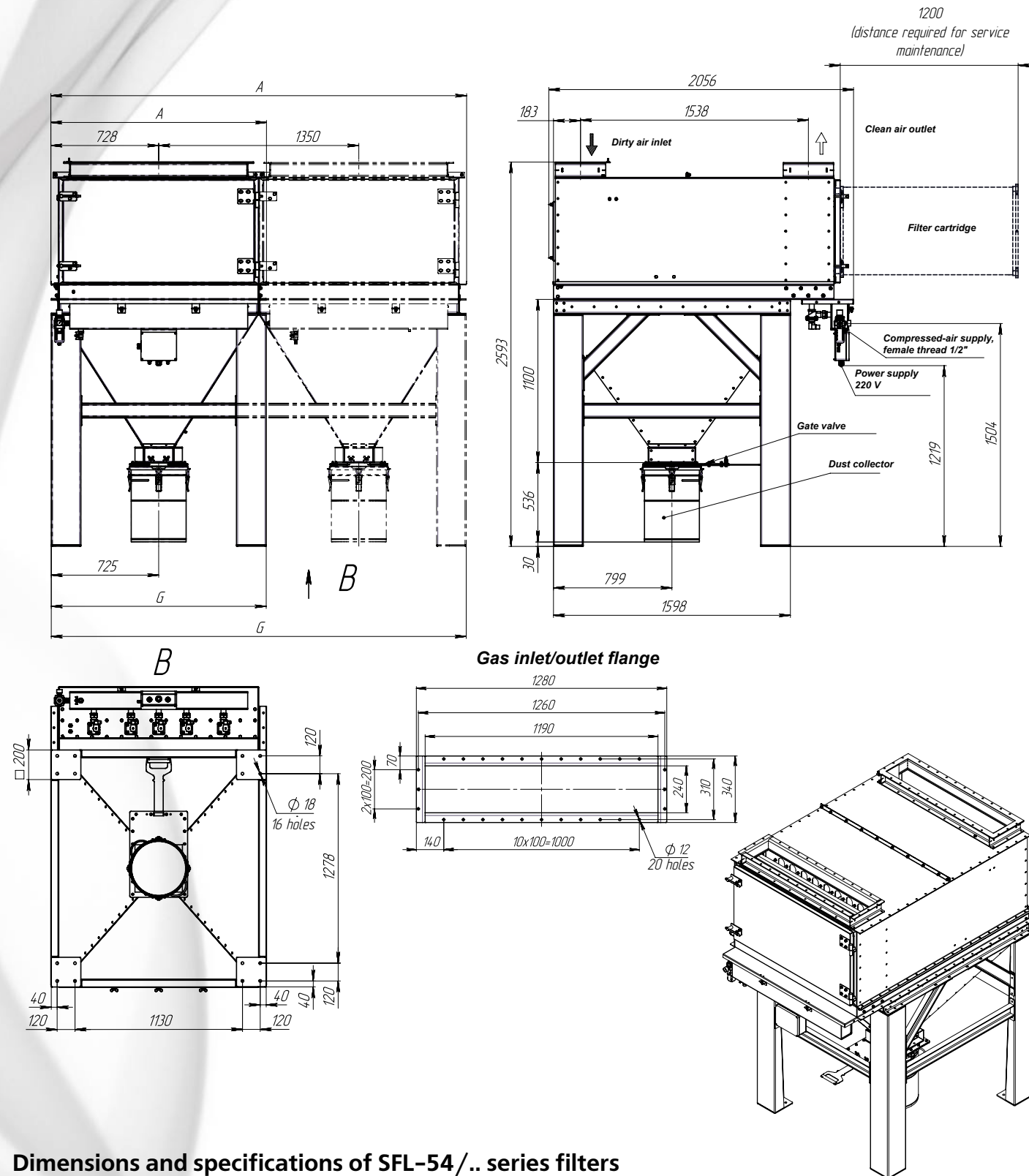

Dimensions and specifications of SFL-54/.. series filters

Filter type	Capacity, m <sup>3</sup> /h	Filtration surface area, m <sup>2</sup>	Compressed-air flowrate, nm <sup>3</sup> /h	Number of cartridges, pcs.	Weight, kg	A, mm	G, mm
SFL-54/1	4,050	54	30	9	920	1,455	1,450
SFL-54/2	8,100	108	30	18	1,680	2,805	2,800
SFL-54/3	12,150	162	60	27	2,440	4,155	4,150
SFL-54/4	16,200	216	60	36	3,200	5,505	5,500

A standard filter is equipped with a manual cut-off gate valve and a drum.  
 Technical characteristics and parameters of products listed in this catalogue may be changed without prior notice.

## General technical drawing of cartridge filter SFL-72/..-GV/DB

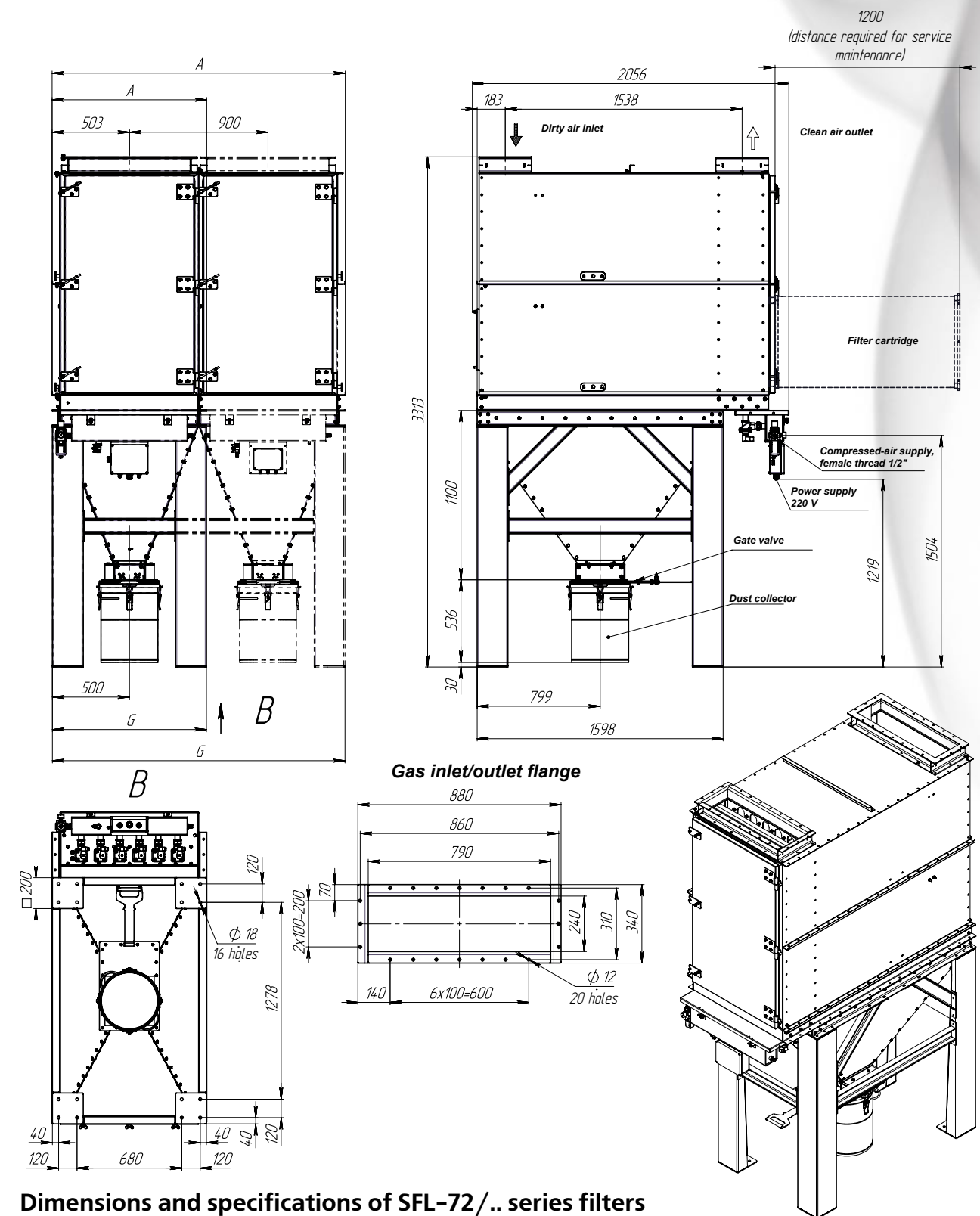

Dimensions and specifications of SFL-72/.. series filters

Filter type	Capacity, m <sup>3</sup> /h	Filtration surface area, m <sup>2</sup>	Compressed-air flowrate, nm <sup>3</sup> /h	Number of cartridges, pcs.	Weight, kg	A, mm	G, mm
SFL-72/1	5,400	72	20	12	1,070	1,005	1,000
SFL-72/2	10,800	144	20	24	1,920	1,905	1,900
SFL-72/3	16,200	216	40	36	2,770	2,805	2,800
SFL-72/4	21,600	288	40	48	3,620	3,705	3,700

A standard filter is equipped with a manual cut-off gate valve and a drum.  
 Technical characteristics and parameters of products listed in this catalogue may be changed without prior notice.



## General technical drawing of cartridge filter SFL-108W/..-GV/DB

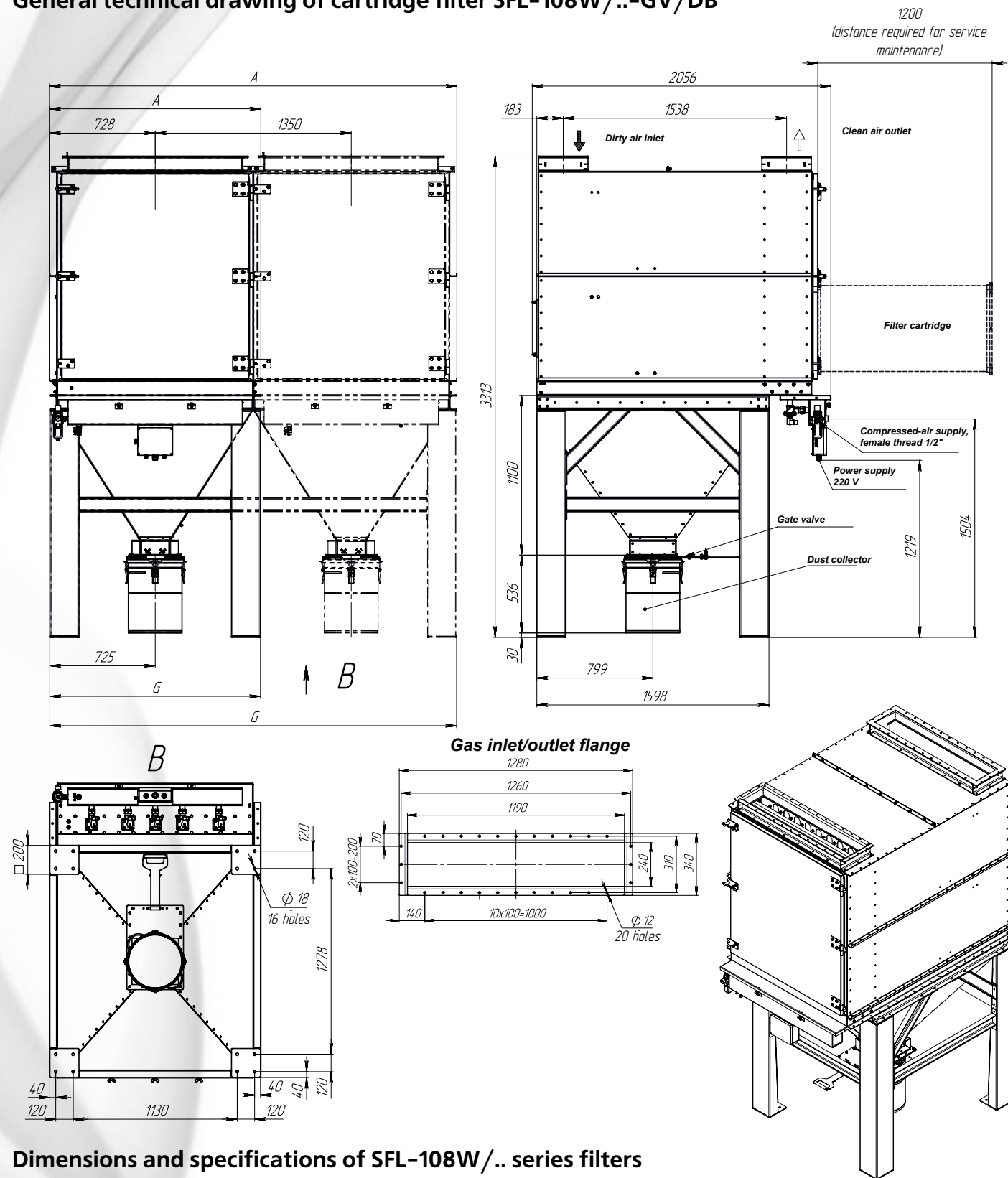

Dimensions and specifications of SFL-108W/.. series filters

Filter type	Capacity, m <sup>3</sup> /h	Filtration surface area, m <sup>2</sup>	Compressed-air flowrate, nm <sup>3</sup> /h	Number of cartridges, pcs.	Weight, kg	A, mm	G, mm
SFL-108W/1	8,100	108	30	18	1,340	1,455	1,450
SFL-108W/2	16,200	216	60	36	2,460	2,805	2,800
SFL-108W/3	24,300	324	90	54	3,580	4,155	4,150
SFL-108W/4	32,400	432	120	72	4,700	5,505	5,500

## General technical drawing of cartridge filter SFL-108/..-GV/DB

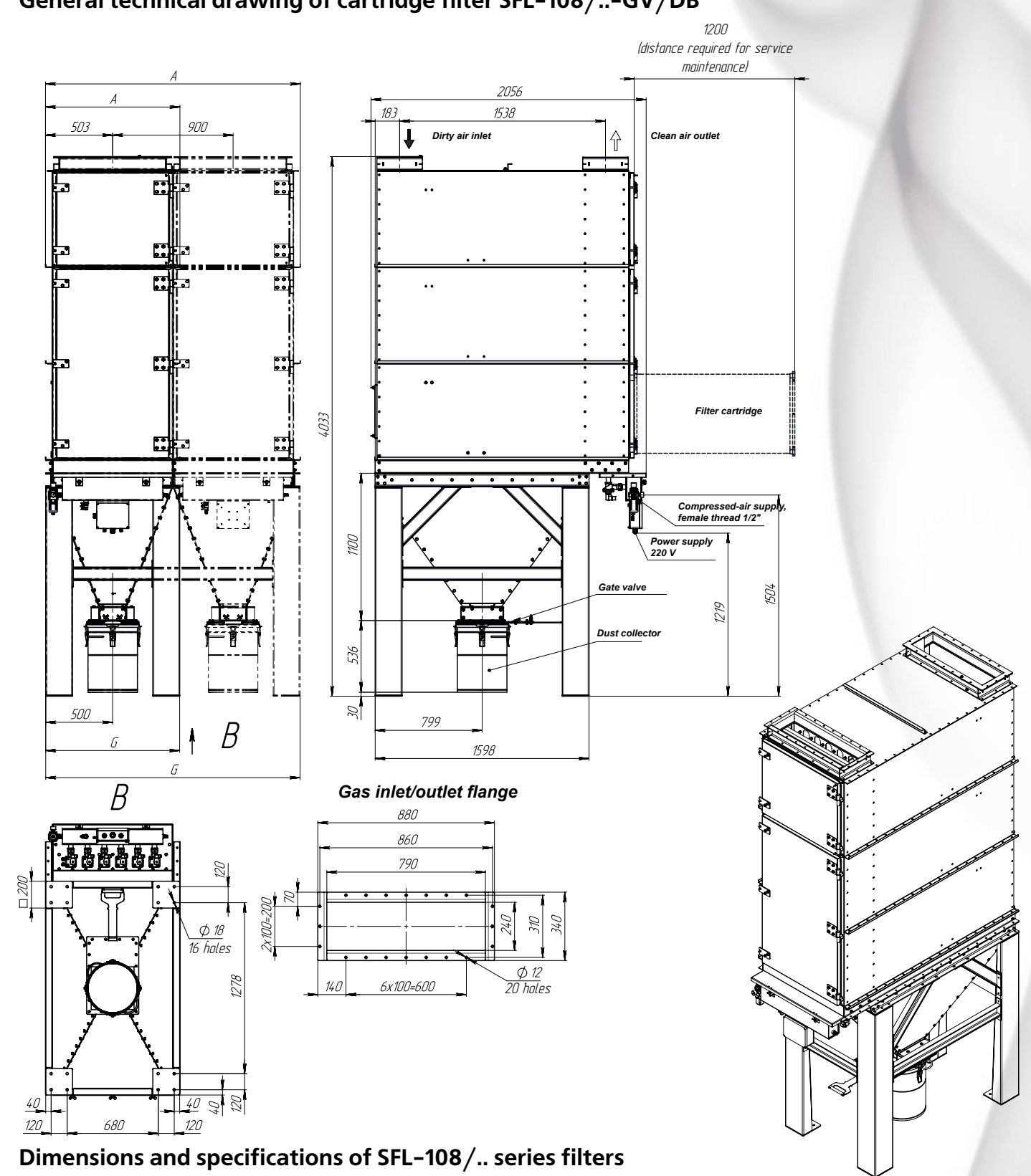

Dimensions and specifications of SFL-108/.. series filters

Filter type	Capacity, m <sup>3</sup> /h	Filtration surface area, m <sup>2</sup>	Compressed-air flowrate, nm <sup>3</sup> /h	Number of cartridges, pcs.	Weight, kg	A, mm	G, mm
SFL-108/1	8,100	108	20	18	1,380	1,005	1,000
SFL-108/2	16,200	216	40	36	2,480	1,905	1,900
SFL-108/3	24,300	324	60	54	3,580	2,805	2,800
SFL-108/4	32,400	432	80	72	4,680	3,705	3,700

A standard filter is equipped with a manual cut-off gate valve and a drum.

Technical characteristics and parameters of products listed in this catalogue may be changed without prior notice.

A standard filter is equipped with a manual cut-off gate valve and a drum.

Technical characteristics and parameters of products listed in this catalogue may be changed without prior notice.



## General technical drawing of cartridge filter SFL-144/..-GV/DB

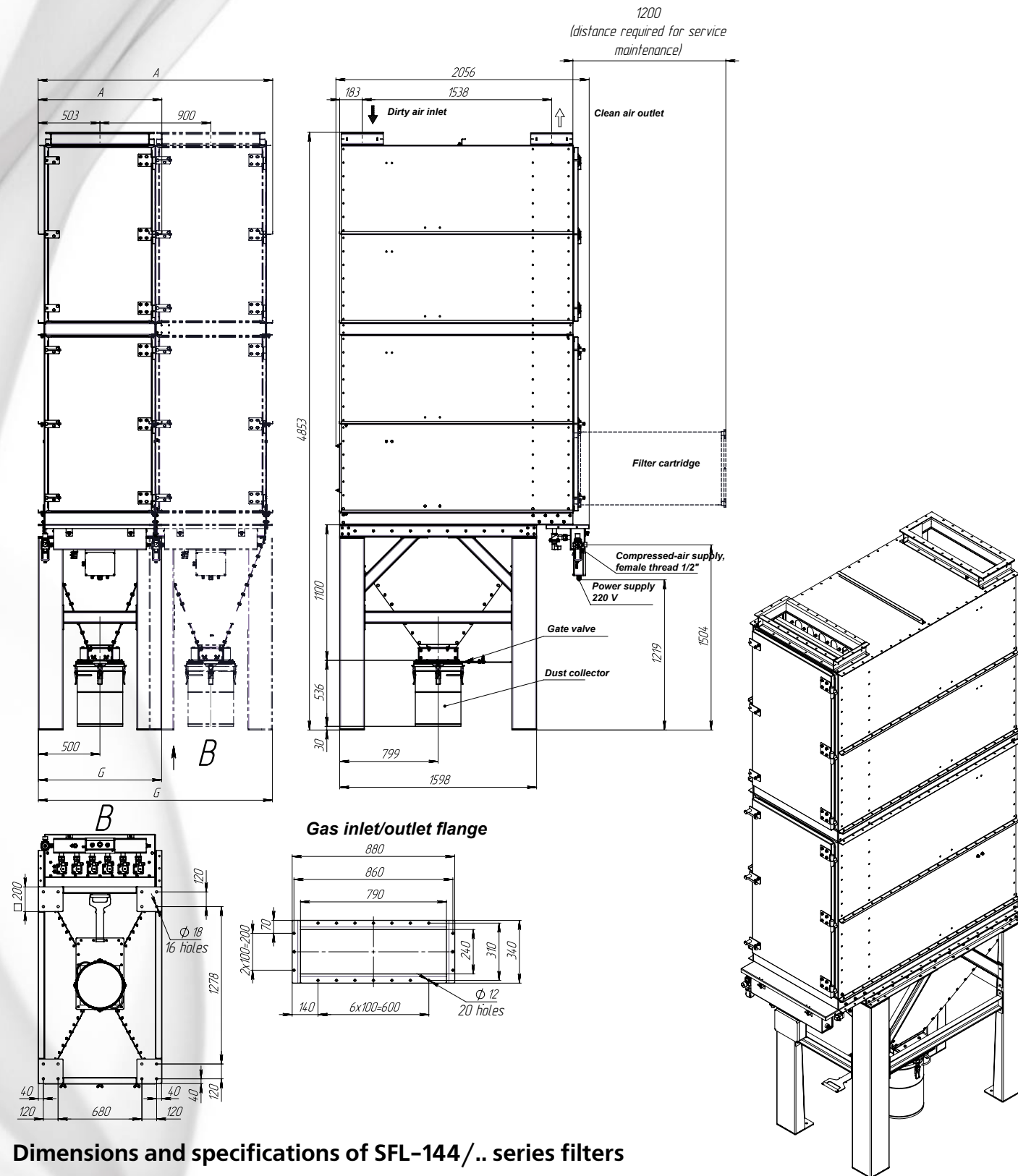

Dimensions and specifications of SFL-144/.. series filters

Filter type	Capacity, m <sup>3</sup> /h	Filtration surface area, m <sup>2</sup>	Compressed-air flowrate, nm <sup>3</sup> /h	Number of cartridges, pcs.	Weight, kg	A, mm	G, mm
SFL-144/1	10,800	144	20	24	1,670	1,005	1,000
SFL-144/2	21,600	288	20	48	3,000	1,905	1,900
SFL-144/3	32,400	432	40	72	4,330	2,805	2,800
SFL-144/4	43,200	576	40	96	5,660	3,705	3,700

## General technical drawing of cartridge filter SFL-162/..-GV/DB

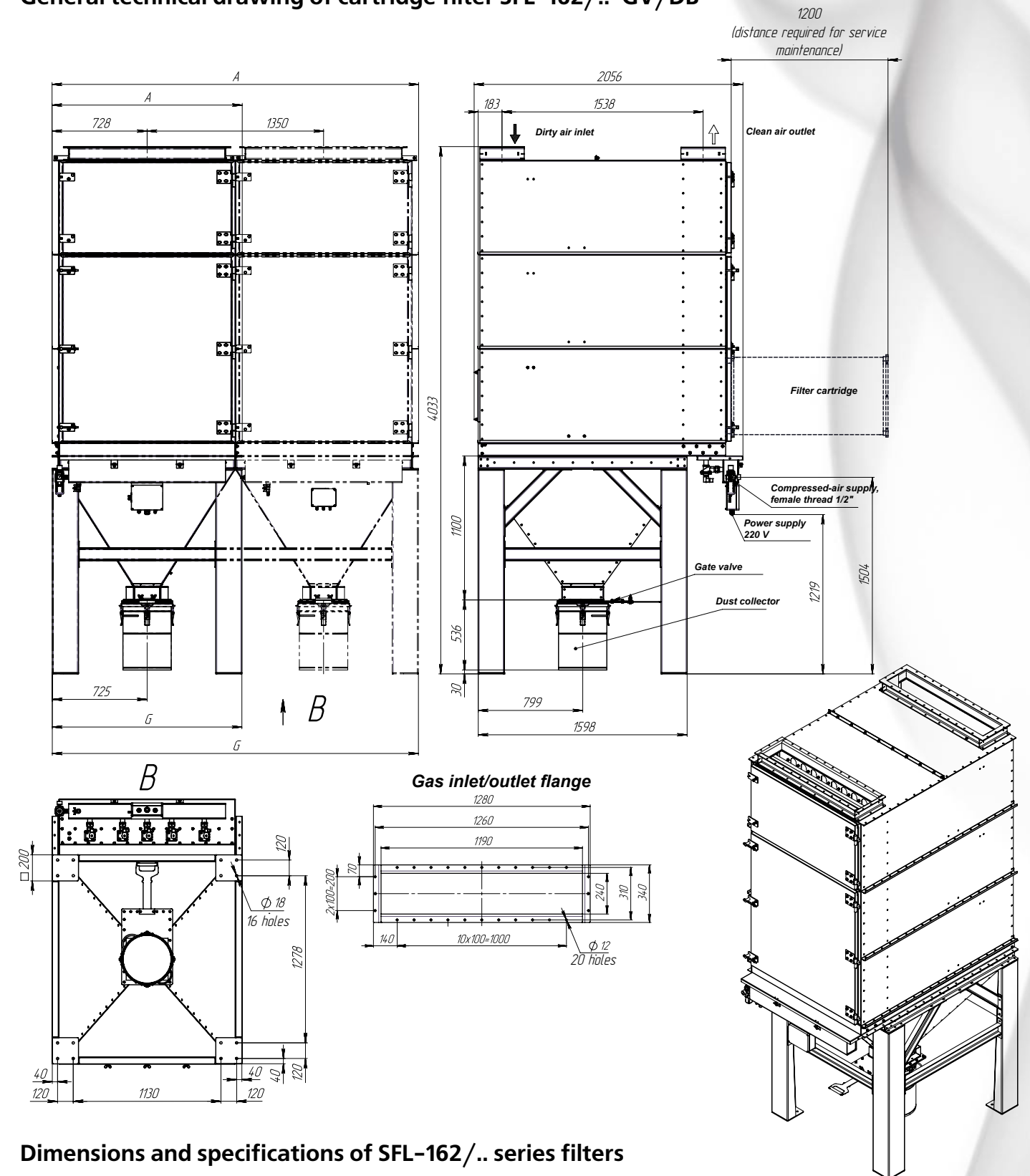

Dimensions and specifications of SFL-162/.. series filters

Filter type	Capacity, m <sup>3</sup> /h	Filtration surface area, m <sup>2</sup>	Compressed-air flowrate, nm <sup>3</sup> /h	Number of cartridges, pcs.	Weight, kg	A, mm	G, mm
SFL-162/1	12,150	162	30	27	1,750	1,455	1,450
SFL-162/2	24,300	324	60	54	3,220	2,805	2,800
SFL-162/3	36,450	486	90	81	4,690	4,155	4,150
SFL-162/4	48,600	648	120	108	6,160	5,505	5,500



## General technical drawing of cartridge filter SFL-216/..-GV/DB

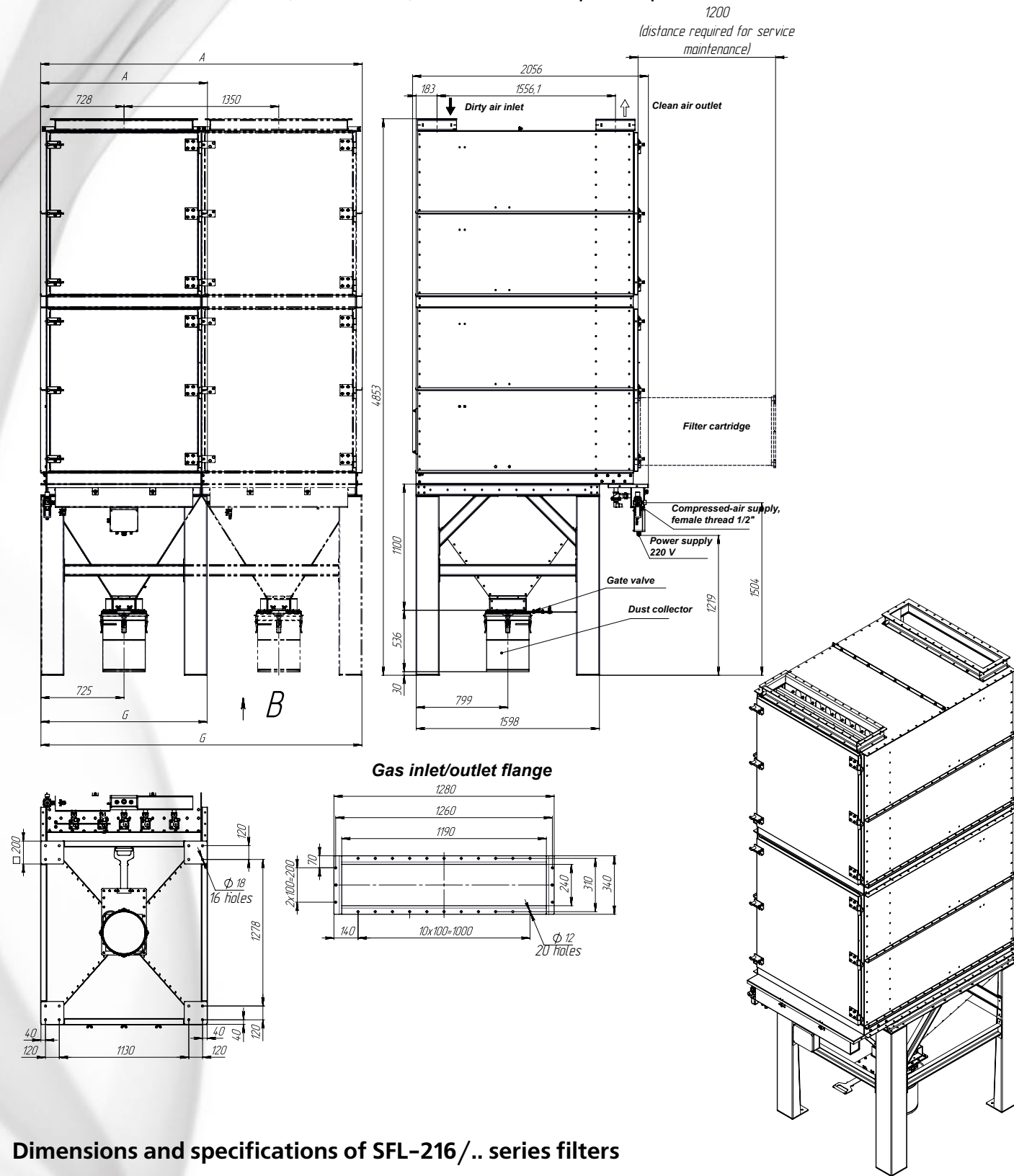

Dimensions and specifications of SFL-216/.. series filters

Filter type	Capacity, m <sup>3</sup> /h	Filtration surface area, m <sup>2</sup>	Compressed-air flowrate, nm <sup>3</sup> /h	Number of cartridges, pcs.	Weight, kg	A, mm	G, mm
SFL-216/1	16,200	216	30	36	2,170	1,455	1,450
SFL-216/2	32,400	432	60	72	3,660	2,805	2,800
SFL-216/3	48,600	648	90	108	5,490	4,155	4,150
SFL-216/4	64,800	864	120	144	7,320	5,505	5,500

A standard filter is equipped with a manual cut-off gate valve and a drum.  
 38 Technical characteristics and parameters of products listed in this catalogue may be changed without prior notice.

## General technical drawing of cartridge filter SFL-360/..-GV/DB

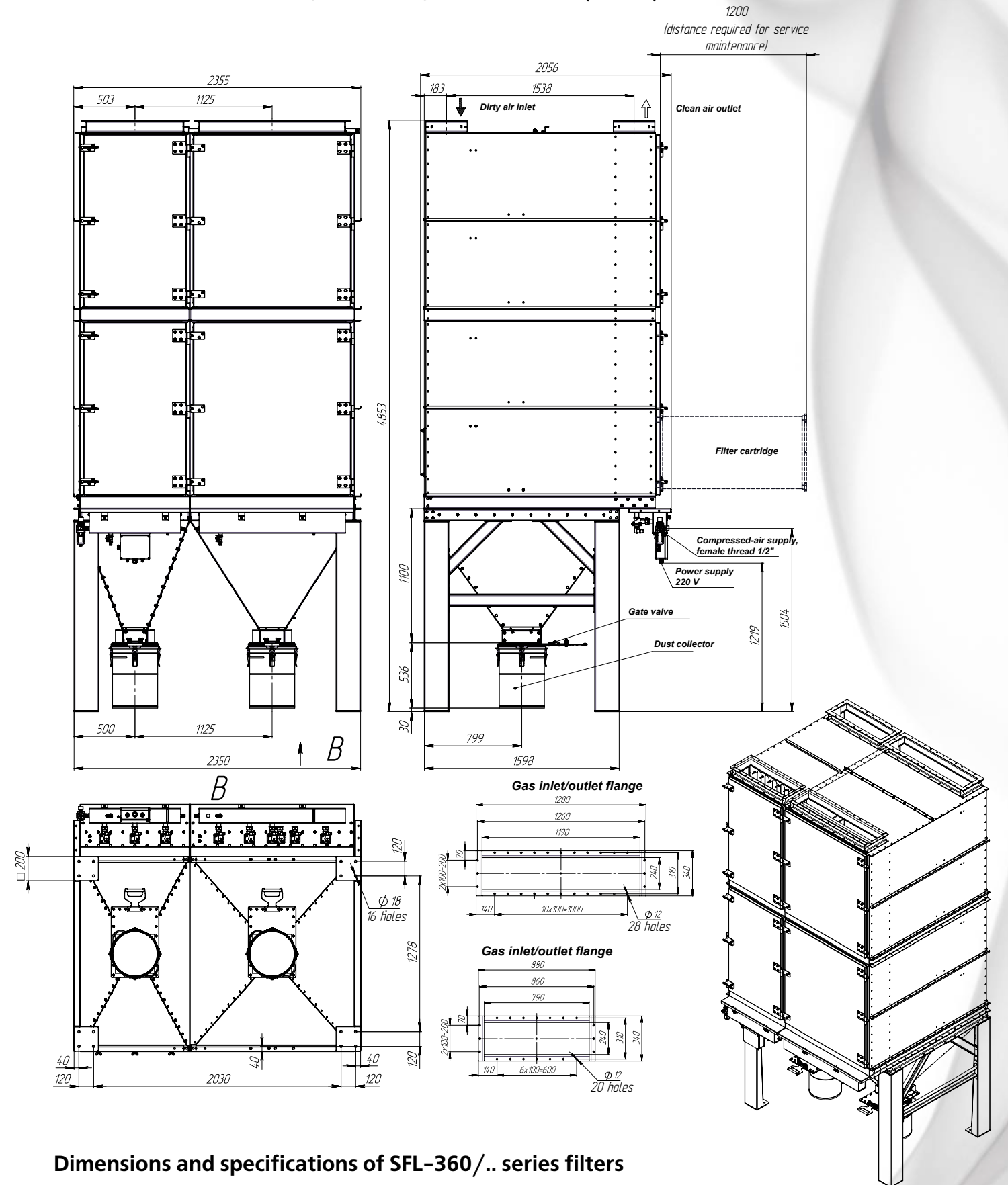

Dimensions and specifications of SFL-360/.. series filters

Filter type	Capacity, m <sup>3</sup> /h	Filtration surface area, m <sup>2</sup>	Compressed-air flowrate, nm <sup>3</sup> /h	Number of cartridges, pcs.	Weight, kg
SFL-360/1	27,000	360	50	60	3,700

A standard filter is equipped with a manual cut-off gate valve and a drum.  
 Technical characteristics and parameters of products listed in this catalogue may be changed without prior notice.



## General technical drawing of SFL spot (silo, conveyor) cartridge filter

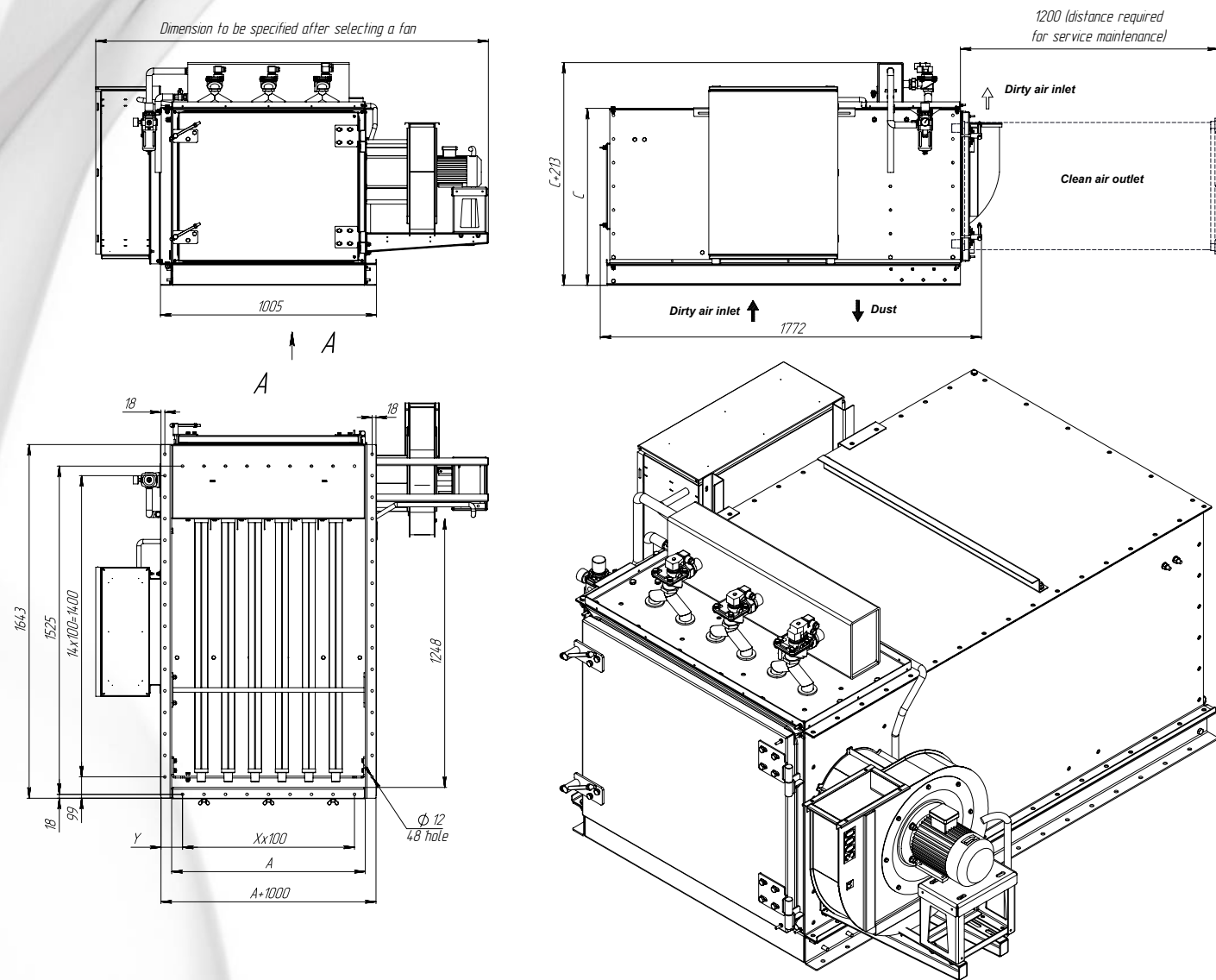

### Description

SFL spot filters are manufactured both in a pressure version (without a fan) to ventilate pressurized silos, bunkers, etc. and in a negative-pressure version (with a fan) to be installed at pouring sites and silos, which require negative pressure.

## Dimensions and specifications of SFL series spot (silo, conveyor) filters

Filter type	Capacity, m <sup>3</sup> /h	Filtration surface area, m <sup>2</sup>	Compressed-air flowrate, nm <sup>3</sup> /h	Number of cartridges, pcs.	Weight, kg	A, mm	C, mm	X	Y, mm
SFL-36	2,700	36	20	6	310	900	822	8	100
SFL-54	4,050	54	20	9	460	1,350	822	13	75
SFL-72	5,400	72	20	12	615	900	1,542	8	100
SFL-108	8,100	108	20	18	920	900	2,262	8	100

The main difference between SFL and SFN filters is that SFL filters have a larger filtration surface area with approximately the same overall dimensions and, accordingly, have higher capacity.

## Possible configuration of inlet/outlet flanges in SFN and SFL filters

In SFN and SFL series filters, the polluted gas input and the cleaned gas outlet are normally arranged at the top (see the figure below). Accordingly, flanges are located on the upper part of the filter. If required, the dirty air inlet flange can be installed

on the back of the filter at the top of its body. The clean gas outlet can be mounted on the side wall of the clean gas chamber.

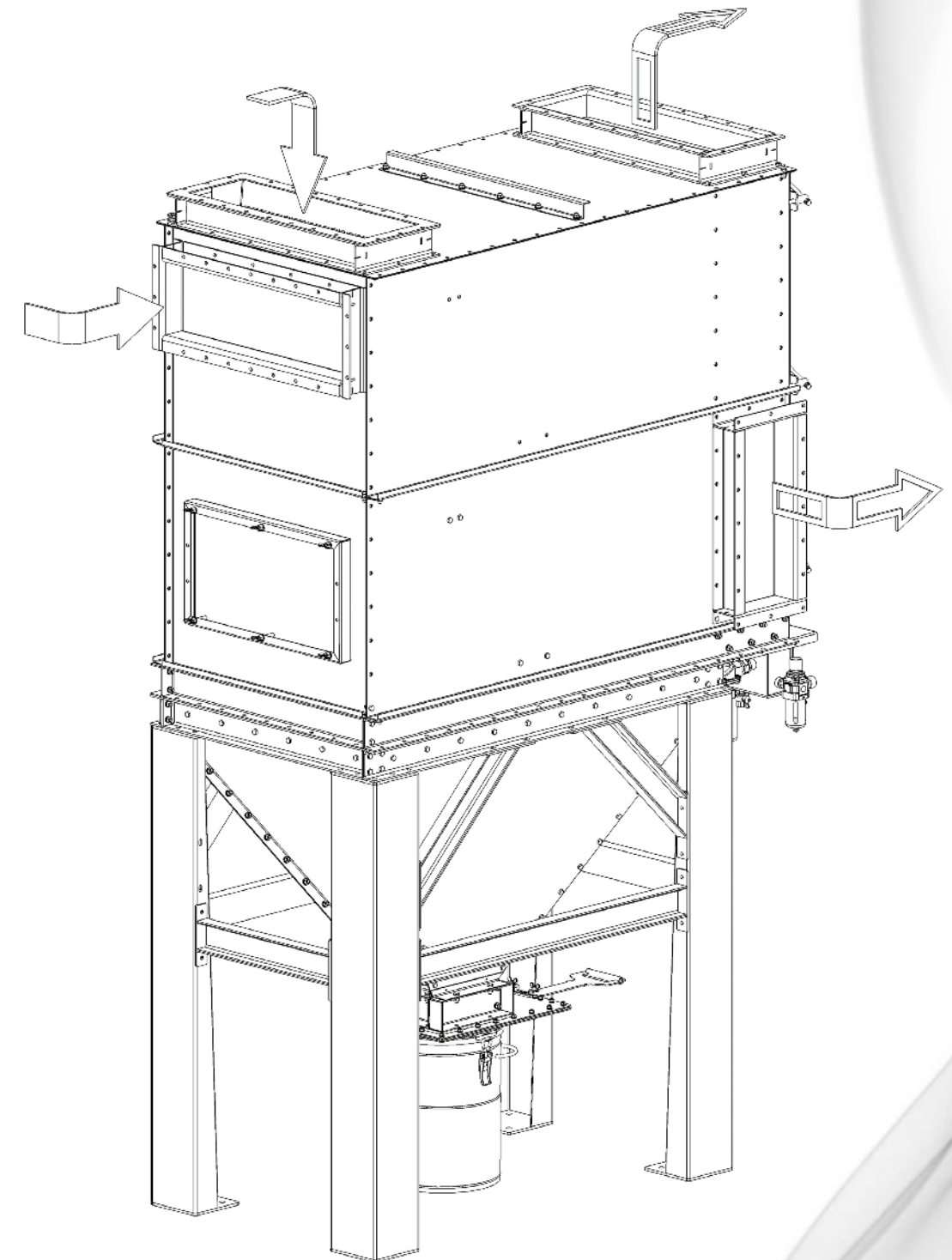

# SFM

Series



# SFM pocket filter with mechanical stirring



**Description**

SFM series filters are a cost-effective way to solve various aspiration tasks. They are single-block semi-automatic non-continuous pocket filters with a filtration surface area of 6 to 45 m<sup>2</sup> and mechanical stirring of filter elements. The fan should be disconnected periodically to regenerate the filter. The filter is used to clean air or gases from various types of dry, loose, and non-sticky dust. The SFM filters are suitable both for indoor and outdoor installations.

- Industries**
- Chemical
  - Metallurgical
  - Metal working
  - Mining
  - Food
  - Pharmaceutical
  - Machine building
  - Production of construction materials
  - Cement production
  - Other industries

**Restrictions in the use of SFM filters (of series and piece production)**

- No structural protection against explosion.
- Not intended for continuous operation.
- Not intended for the following types of dust:
  - for smoldering and self-igniting dust;
  - for fibrous dust;
  - for sticky dust;
  - for dust with moisture.

- Applications**
- Aspiration of silo and bunker loading/unloading
  - Aspiration of process and associated equipment
  - Aspiration of pouring sites, conveyor belts, conveyors, and elevators
  - Aspiration of crushers, mills, screens, refrigerators, mixers, and dispensers
  - Aspiration of shot blasting and surface treatment

**Filter Elements**

Filter elements of SFM filters are flat, smooth woven pockets sewn in the upper part into one piece. A metal mesh frame stretched on a rectangular metal bar chassis is inserted inside each pocket.



## Pocket filter with mechanical stirring



## Type of filter elements used in SFM series filters

Designation	Filter type	Filtration surface, m <sup>2</sup>	Pocket material
PF-P6-SFM	SFM 06	6	Polymeric ester
PF-P13-SFM	SFM 13	13	Polymeric ester
PF-P23-SFM	SFM 23	23	Polymeric ester
PF-P30-SFM	SFM 30	30	Polymeric ester
PF-P45-SFM	SFM 45	45	Polymeric ester
PF-C6-SFM	SFM 06	6	Antistatic polyester
PF-C13-SFM	SFM 13	13	Antistatic polyester
PF-C23-SFM	SFM 23	23	Antistatic polyester
PF-C30-SFM	SFM 30	30	Antistatic polyester
PF-C45-SFM	SFM 45	45	Antistatic polyester

## Special features of SFM filter regeneration

Since SFM series filters are regenerated by mechanical stirring, they need to be stopped periodically. Their operating cycle is about 2 hours, stirring is 90 seconds (factory settings, adjustable parameter). During regeneration, airflow through the filter should be stopped. This can be done by installing a special control unit on the filter to stop the fan before starting the stirring motor, by manually pressing a regeneration activation button, and to start up the stirring motor after its run-out. At the end of regeneration,

the control unit automatically stops the stirring and starts up the fan until the next pressing of the regeneration activation button. A standard filter is not equipped with a fan, therefore the control unit only provides a manual start and automatic shutdown of the stirring motor.

## SFM Filter Design

SFM filters of series production consist of a body with a conical dust collector (see the figure on the right) mounted on supports, a dust collection container with a manual cut-off butterfly valve, and a regeneration system. Filters are equipped with a regeneration system by mechanical stirring of filter elements. Possible sizes of filters, relevant filtration areas, and rated capacities are shown in the table below.

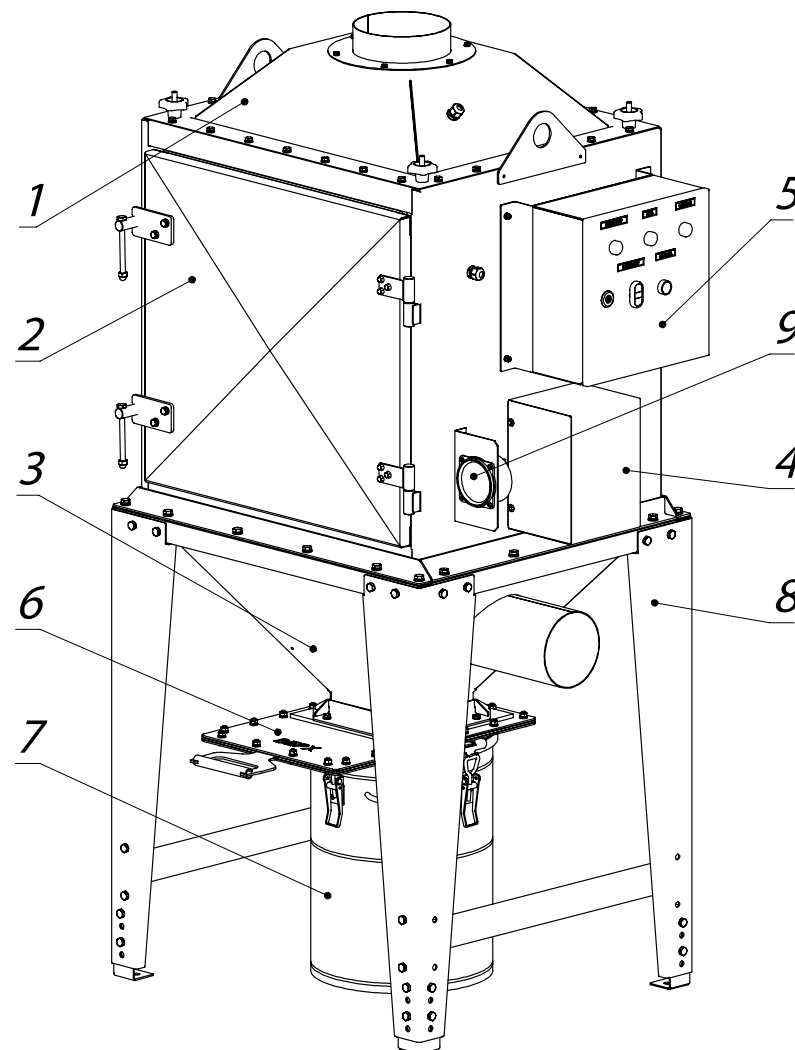

## Basic Elements of SFM Filter

- 1 – cleaned air collector
- 2 – filter body
- 3 – filter bunker
- 4 – stirring system engine casing
- 5 – control panel
- 6 – valve gate
- 7 – dust collector
- 8 – filter support structure
- 9 – differential pressure gage

## General technical drawing of SFM series filter

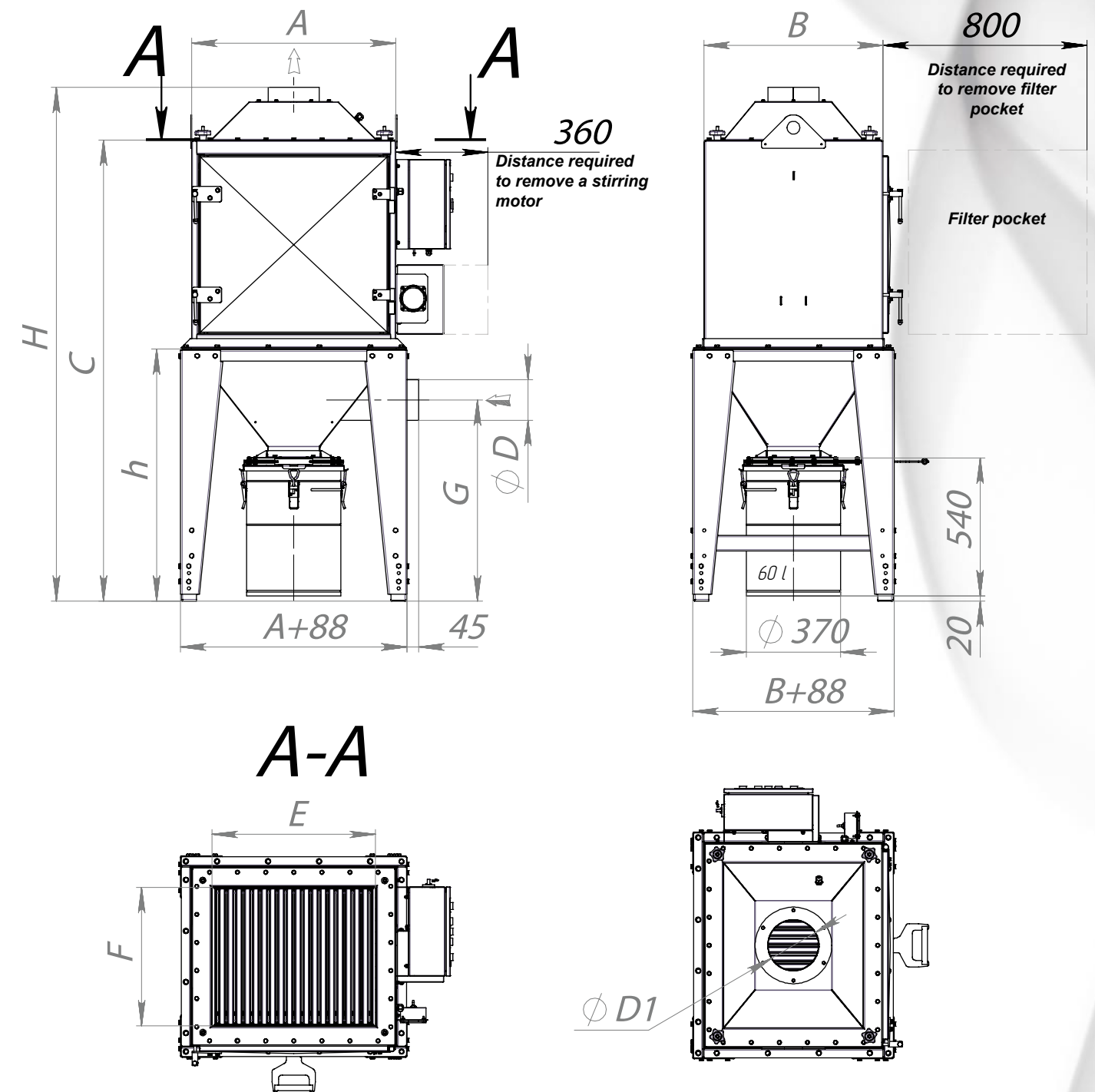

## Dimensions and Specifications of SFM Filters

Filter type	Capacity, m <sup>3</sup> /h	Filtration surface, m <sup>2</sup>	Weight, kg	A, mm	B, mm	C, mm	D, mm	D1, mm	H, mm	h, mm	E, mm	F, mm	G, mm
SFM 06	550	6	187	500	700	1,805	139	200	2,012	988	350	550	788
SFM 13	1,200	13	221	800	700	1,805	159	200	2,012	988	650	550	788
SFM 23	2,100	23	270	800	945	2,080	159	250	2,218	1,040	650	795	777
SFM 30	2,800	30	290	1,000	945	2,080	249	250	2,280	1,105	850	795	860
SFM 45	4,200	45	310	1,000	945	2,505	314	315	2,710	1,105	850	795	863

## SFM filter delivery set

Standard delivery set	Additional configuration
Filter housing with service door	
Conical dust bin with inlet nozzle	Fan
Mechanical regeneration system with a control unit	
Supports	Additional dust discharge and collection systems
Cleaned air outlet collector	
PF-P...-SFM or PF-C...-SFM filter pockets with frames	
Earthing line (for antistatic version)	SFM-30 and SFM-45 modules can be mirrored

## SFM-20 spot pressure filter

SFM spot filters can be manufactured both in a pressure version (without a fan) to ventilate pressurized silos, bunkers, etc. and in a negative-pressure version (with a fan) to be installed at pouring sites and silos, which require negative pressure.

SFM-20 spot pressure filter is designed exclusively for installation at silos or bunkers loaded under overpressure. It differs from other SFM series filters by the top location of its service area.

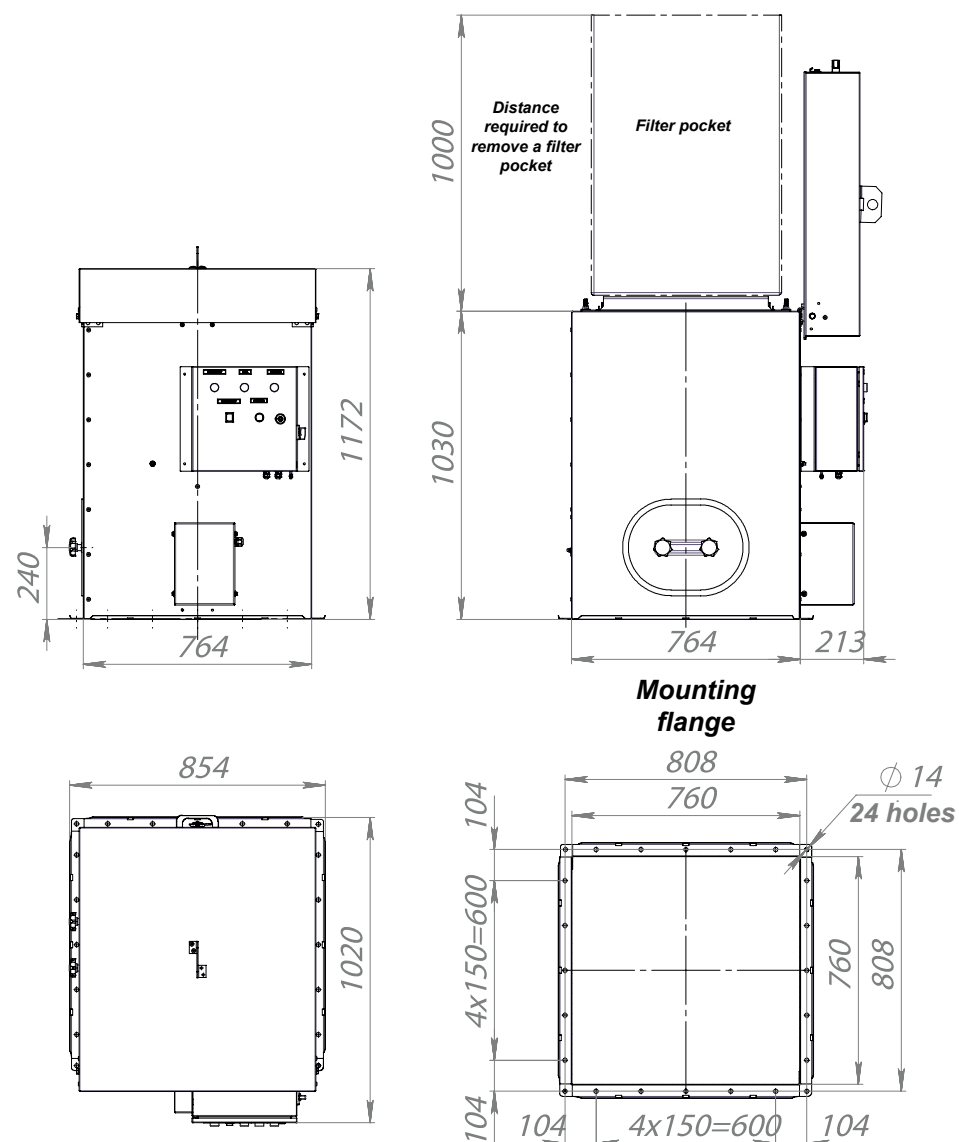

## Specifications

Filter type	Capacity, m <sup>3</sup> /h	Filtration surface, m <sup>2</sup>	Weight, kg
SFM 20	2,000	20	150

## General technical drawing of SFM spot (silo, conveyor) filter

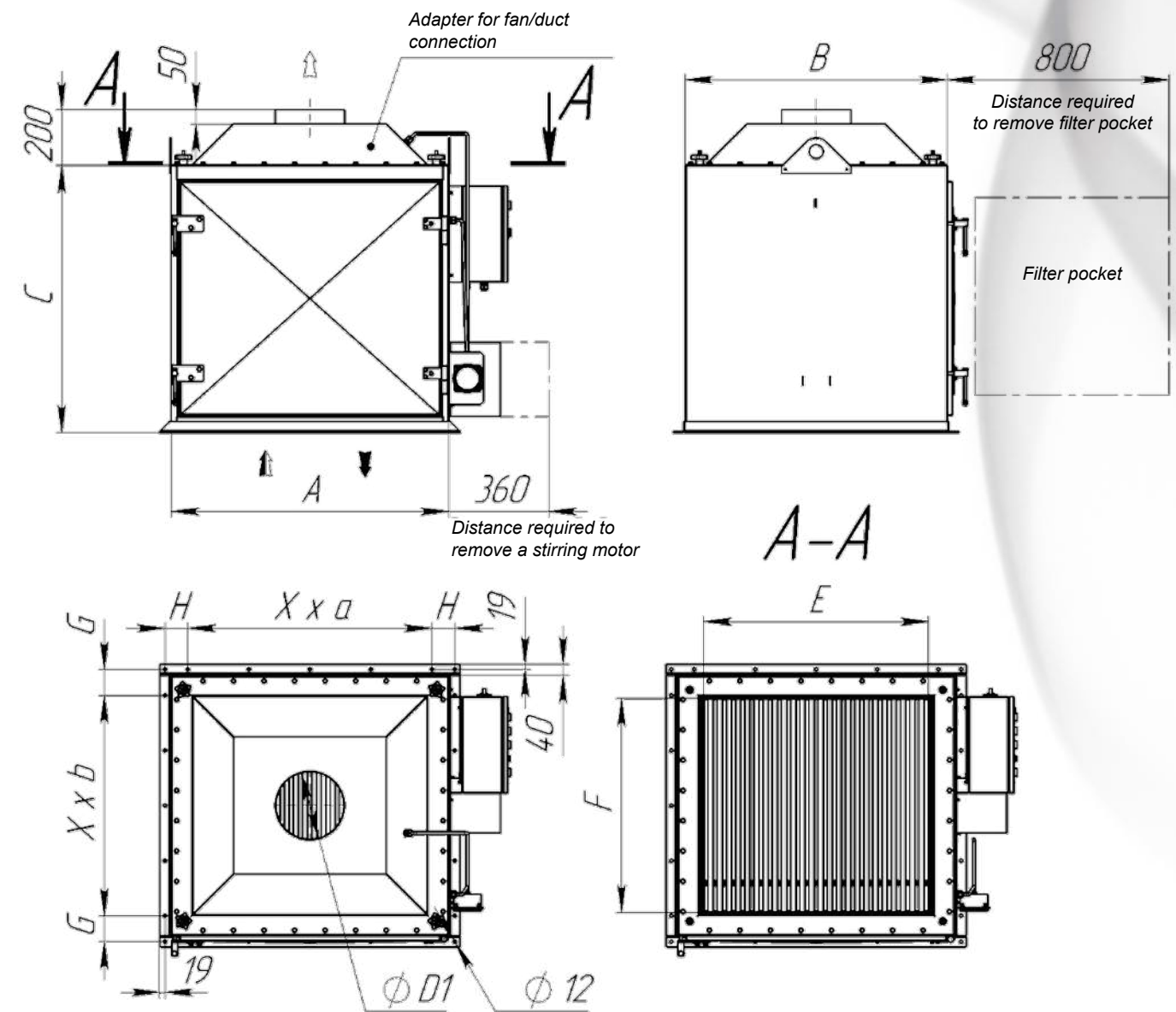

## Dimensions and Specifications of SFM Filters

Filter type	Capacity, m <sup>3</sup> /h	Filtration surface, m <sup>2</sup>	Weight, kg	A, mm	B, mm	C, mm	D1, mm	E, mm	F, mm	G, mm	H, mm	Xxa, mm	Xxb, mm
SFM 06	550	6	130	500	700	816	199	436	634	72	172	200	3x200
SFM 13	1,200	13	156	800	700	816	199	736	634	72	122	3x200	3x200
SFM 23	2,100	23	195	800	945	972	249	736	879	94.5	122	3x200	4x200
SFM 30	2,800	30	205	1,000	945	972	249	936	879	94.5	82	4x220	4x200
SFM 45	4,200	45	225	1,000	945	1397	314	936	879	94.5	82	4x220	4x200



# SFS

Series

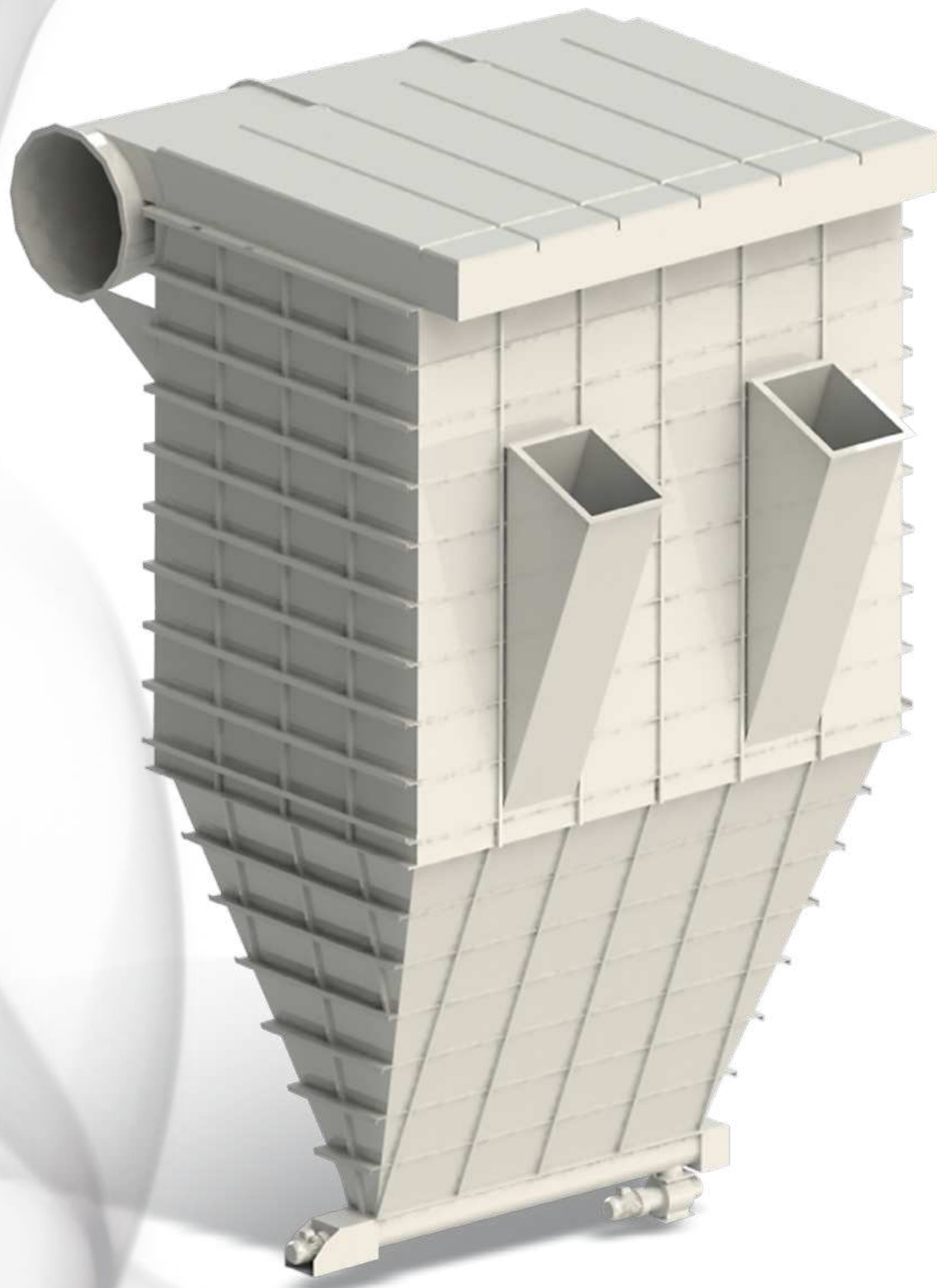

Bag filter with cylindrical bags and pulse regeneration

# SFS pulse regeneration bag filter



## Description

SFS pulse regeneration bag filter is a classic and most versatile fabric filter.

The required capacity can be achieved both by adding sections to the filter design and by using the set configuration of several filters.

Despite its impressive dimensions, the filter has no elements exceeding transport dimensions of a standard 40-ft container.

## Industries

- Chemical
- Metallurgical
- Metal working
- Mining
- Machine building
- Production of construction materials
- Cement production
- Other industries

## SFS Filter Applications

- Cleaning devices of relatively high capacity from 15 thousand m<sup>3</sup>/h to 1.5–2.0 million m<sup>3</sup>/h.
- Aspiration gases with a high dust content (up to 60 g/m<sup>3</sup>).
- Flue gases with a high content of fine particles, such as soot.
- Cleaning of high-temperature gases. SFS bag filters are manufactured in a common industrial version with an operating temperature up to 150 °C, and in a high-temperature version – up to 260 °C. If it is required to clean gases with a temperature of more than 260 °C, an air/air cooler manufactured by SovPlym JSC or a waste heat boiler should be installed upstream of the filter.
- Cleaning devices installed outdoors or in tall buildings SFS bag filter is serviced from above, and a tent cover should be provided above the filter to protect it from precipitation.
- Aspiration of explosive materials. In this case, the filter body is strengthened with a positive overpressure of up to 40 kPa. To ward off explosion from the filter, rupture discs are installed on its body.
- Aspiration gases with a high content of chemically active compounds. In this case, parts of the filter body exposed to chemically active dust are made of stainless steel, and a required amount of neutralizing agent (lime, sodium carbonate, etc.) is injected into the dust-air mixture.



## Design Features of SFS Bag Filters

SFS pulse regeneration bag filters are designed to clean process gases and aspiration emissions from fine dust. The filters can be used in any industry that applies technology with the generation of dusty gases or air.

The filter consists of a body and mechanical equipment. The body is a bearing structure. It is divided into clean and dirty gas chambers by a horizontal partition – a base plate with holes to mount filter bags. The filter bags are arranged in a dirty gas chamber. Their mounting is one-sided, on the side of the clean gas chamber.

The upper part of the clean gas chamber is equipped with removable covers to provide access to the bags during maintenance. The dirty gas chamber is a single section without partitions.

The clean gas chamber is divided into sections by vertical partitions. Such configuration allows to install cut-off valves on each section of the bag filter for “off line” regeneration (during “off line” regeneration, part of the filter is disconnected from a draft agitator, operating air stops moving through the filter fabric, and compressed-air cleaning pulses reach maximum efficiency).

The bottom of the filter body is made up of pyramidal or slotted bunkers.

Fabric with different physical properties of BWF ENVIROTEC and other leading manufacturers is used as filter fabric. The choice of fabric is based on dust and gas flow characteristics and, above all, on filtration process temperature mode.

Compressed-air pressure required for the regeneration system to operate in the dedusting unit is 0.4–0.6 MPa. Compressed air should be dried and cleaned at least as Class 5 according to GOST 17433-80.

Filter size, fabric type, its configuration, implementation, and climatic design are determined when developing working documentation for a gas cleaning plant based on a checklist or customer’s specifications containing full information on dust and gas flow parameters and dust properties.

## Reconstruction of Electrical Filters into SFS Bag Filters

Today industrial companies operate electrical filters with efficiency inconsistent with modern requirements for the purification of process gases and aspiration air. The most rational method to reduce residual concentration of dust particles to less than 20 mg/nm<sup>3</sup> is to reconstruct electric filters into bag filters.

SovPlym JSC has developed engineering solutions to reconstruct both horizontal and vertical electric filters into SFS bag filters. It is possible to reconstruct aspiration systems by preserving the electric filter body or by completely replacing the body and supporting structures. The reconstruction method is selected depending primarily on the state of metal structures of the electric filter body and compliance with requirements for filter bag strength characteristics (i.e. corrosion or abrasive wear).

An important advantage of a bag filter over an electric one is the possibility to seamlessly modernize it to meet stringent requirements of environmental legislation by simply replacing filter materials. For example, bags with a guaranteed degree of purification up to 20 mg/m<sup>3</sup> or up to 10 mg/m<sup>3</sup>, and even up to 3–4 mg/m<sup>3</sup> can be installed in the same filter bag body.

Also, an obvious advantage of all options to reconstruct electric filters is the possibility to use the existing gas duct system, metal structures, and dust discharge systems.

## Filter Elements of SFS Bag Filters



### Description

Filter elements are cylindrical bags on a wire metal frame with a diameter of 150 mm, the bags can be 3, 4.5 or 6 meters long. To install the filter in the existing body, frame and bags of non-standard length can be manufactured. The bags are made of various types of fabric: polyester, polypropylene, and polyamide. Frame material is galvanized or stainless wire, depending on the filter design.

### General Specifications of SFS Bag Filters

Parameter	From	To
Temperature of the flow to be cleaned	-40 °C	260 °C
Air handling capacity (m <sup>3</sup> /h)	15,000	2,000,000
Initial dust content (g/m <sup>3</sup> )	0.5	60
Final dust content (g/m <sup>3</sup> )	0.1	20
Filter area (m <sup>2</sup> )	141	12,600

Technical characteristics and parameters of products listed in this catalogue may be changed without prior notice.



## Example of decoding marking of bag filters (model range)

SFS	50	100	/	2	-	6.0	B	S	H
SFS	X	XXX	/	XX	-	XX	X	X	X
1	2	3		4		5	6	7	8
1.	Filter type: SFS bag filter			7.	Filter body material:				
2.	Section type:				S – ferrous metal				
	50 – section for 50 bags				N – stainless steel				
3.	Number of bags, pcs.			8.	Additional options:				
4.	Number of sections, pcs.				H – without cover				
5.	Filter bag length, m:				D – with cover				
6.	Bunker type:				W – winterized				
	B – slotted				K – acid resistant				
	P – pyramidal				Ex – explosion-proof				

## Different configurations are available:

- only clean gas chambers and filter elements to be installed in the body of an existing old bag or electric filter;
- version without bunker – in its own body, without discharge devices, to be installed on the existing bunker or silo;
- in its own body, on its own supports, with a continuous-dust discharge device (rotary valve) allowing to attach pneumatic transport or unload dust using a scraper or screw conveyor;
- if a bag filter is installed outside for maintenance (replacement of filter elements), a tent roof is included in the delivery set.

## Filter versions with sections for 50 bags

Filter type	Configuration of sections	Number of bags, pcs.	Number of sections, pcs.	Bag diameter, mm	Bag length, m	Filtration area, m <sup>2</sup>	Filter capacity, m <sup>3</sup> /h, at a filtration rate, m <sup>3</sup> /min			Overall dimensions, m			Weight, t
							1.0	1.5	2.0	L	B	H	
SFS 50 100/2		100	2	150	3.0	140	8,400	12,600	16,800	2.5	2.5	8.0	5.8
					4.5	210	12,600	18,900	25,200	2.5	2.5	9.5	6.8
					6.0	280	16,800	25,200	33,600	2.5	2.5	11.0	7.8
SFS 50 150/3		150	3	150	3.0	210	12,600	18,900	25,200	3.7	2.5	8.0	7.4
					4.5	315	18,900	28,350	37,800	3.7	2.5	9.5	9.0
					6.0	420	25,200	37,800	50,400	3.7	2.5	11.0	10.5
SFS 50 200/4		200	4	150	3.0	280	16,800	25,200	33,600	4.9	2.5	8.0	10.0
					4.5	420	25,200	37,800	50,400	4.9	2.5	9.5	12.0
					6.0	560	33,600	50,400	67,200	4.9	2.5	11.0	14.0
SFS 50 250/5		250	5	150	3.0	350	21,000	31,500	42,000	6.1	2.5	8.0	14.4
					4.5	525	31,500	47,250	63,000	6.1	2.5	9.5	17.0
					6.0	700	42,000	63,000	84,000	6.1	2.5	11.0	19.5
SFS 50 300/6		300	6	150	3.0	420	25,200	37,800	50,400	7.3	2.5	8.0	16.5
					4.5	630	37,800	56,700	75,600	7.3	2.5	9.5	19.5
					6.0	840	50,400	75,600	100,800	7.3	2.5	11.0	22.0

## Versions of filter configuration in sets

Filter type	Filter configuration in sets	Number of bags, pcs.	Number of sections, pcs.	Bag diameter, mm	Bag length, m	Filtration area, m <sup>2</sup>	Filter capacity, m <sup>3</sup> /h, at a filtration rate, m <sup>3</sup> /min			Overall dimensions, m			Weight, t
							1.0	1.5	2.0	L	B	H	
SFS 75 900/12		900	12	150	6.0	2,520	151,200	226,800	302,400	7.0	12.0	12.0	63.0
SFS 75 1800/24		1800	24	150	6.0	5,040	302,400	453,600	604,800	14.0	12.0	12.0	128.0
SFS 75 3600/48		3600	48	150	6.0	10,080	604,800	907,200	1,209,600	28.0	14.0	12.0	260.0

## Filter versions with sections for 75 bags

Filter type	Configuration of sections	Number of bags, pcs.	Number of sections, pcs.	Bag diameter, mm	Bag length, m	Filtration area, m <sup>2</sup>	Filter capacity, m <sup>3</sup> /h, at a filtration rate, m <sup>3</sup> /min			Overall dimensions, m			Weight, t
							1.0	1.5	2.0	L	B	H	
SFS 75 150/2		150	2	150	3.0	210	12,600	18,900	25,200	2.5	3.6	9.0	8.3
					4.5	315	18,900	28,350	37,800	2.5	3.6	10.5	9.8
					6.0	420	25,200	37,800	50,400	2.5	3.6	12.0	11.4
SFS 75 225/3		225	3	150	3.0	315	18,900	28,350	37,800	3.7	3.6	9.0	10.6
					4.5	472.5	28,350	42,525	56,700	3.7	3.6	10.5	12.8
					6.0	630	37,800	56,700	75,600	3.7	3.6	12.0	15.2
SFS 75 300/4		300	4	150	3.0	420	25,200	37,800	50,400	4.9	3.6	9.0	13.0
					4.5	630	37,800	56,700	75,600	4.9	3.6	10.5	16.0
					6.0	840	50,400	75,600	100,800	4.9	3.6	12.0	19.1
SFS 75 375/5		375	5	150	3.0	525	31,500	47,250	63,000	6.1	3.6	9.0	18.4
					4.5	787.5	47,250	70,875	94,500	6.1	3.6	10.5	21.6
					6.0	1,050	63,000	94,500	126,000	6.1	3.6	12.0	25.0
SFS 75 450/6		450	6	150	3.0	630	37,800	56,700	75,600	7.3	3.6	9.0	23.8
					4.5	945	56,700	85,050	113,400	7.3	3.6	10.5	27.8
					6.0	1,260	75,600	113,400	151,200	7.3	3.6	12.0	31.8

### General technical drawing of bag filter SFS 50 100/2-3.0

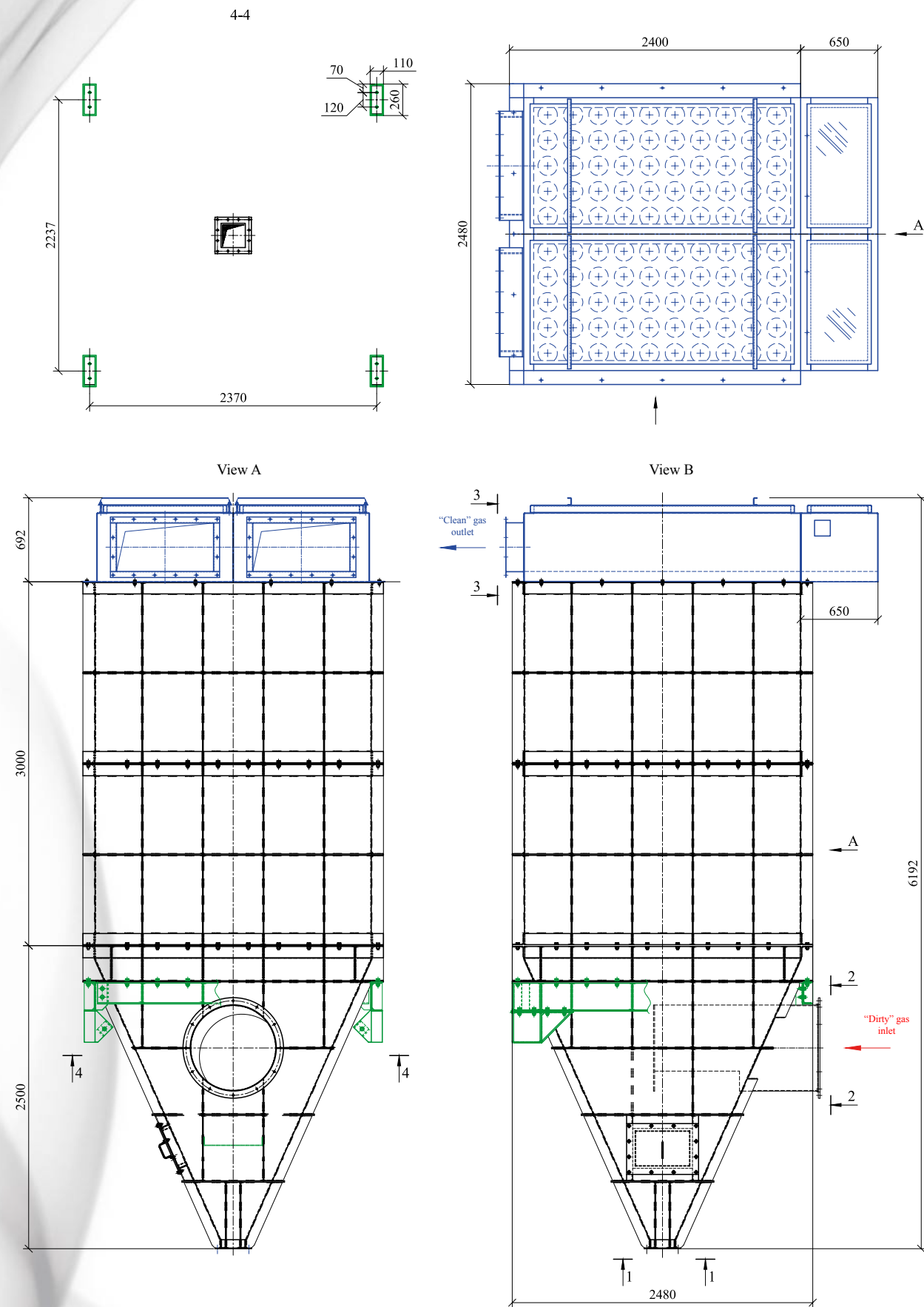

### SFS 50 100/2-3.0 Filter Specifications

Filter type	Capacity, m <sup>3</sup> /h	Bag length, m	Number of sections, pcs.	Filtration area, m <sup>2</sup>	Number of bags, pcs.
SFS 50 100/2-3.0	16,800	3.0	2	140	100

### General technical drawing of bag filter SFS 75 150/2-3.0

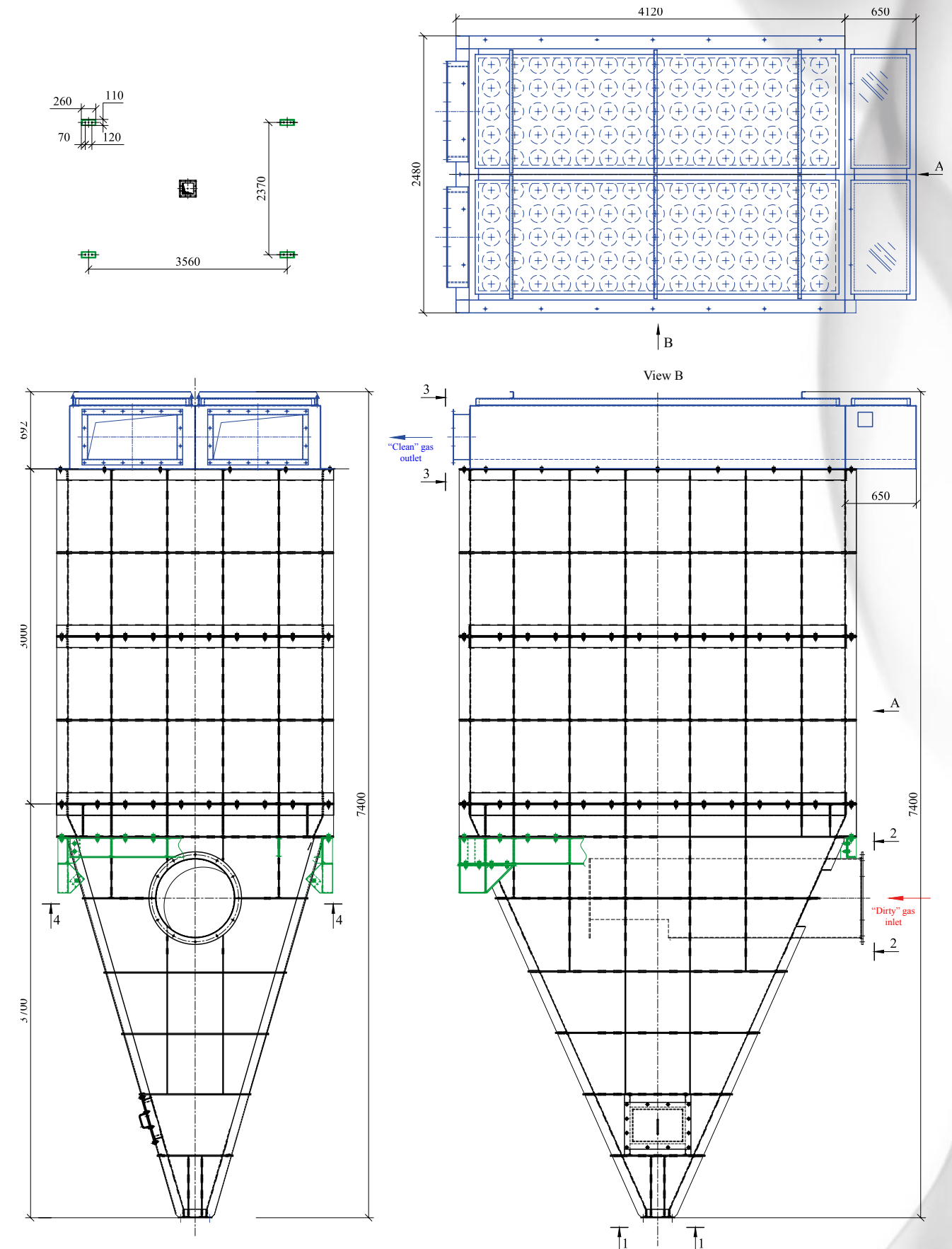

### SFS 75 150/2-3.0 Filter Specifications

Filter type	Capacity, m <sup>3</sup> /h	Bag length, m	Number of sections, pcs.	Filtration area, m <sup>2</sup>	Number of bags, pcs.
SFS 75 150/2-3.0	25,200	3.0	2	210	150



## General technical drawing of bag filter SFS 75 225/3-4.5

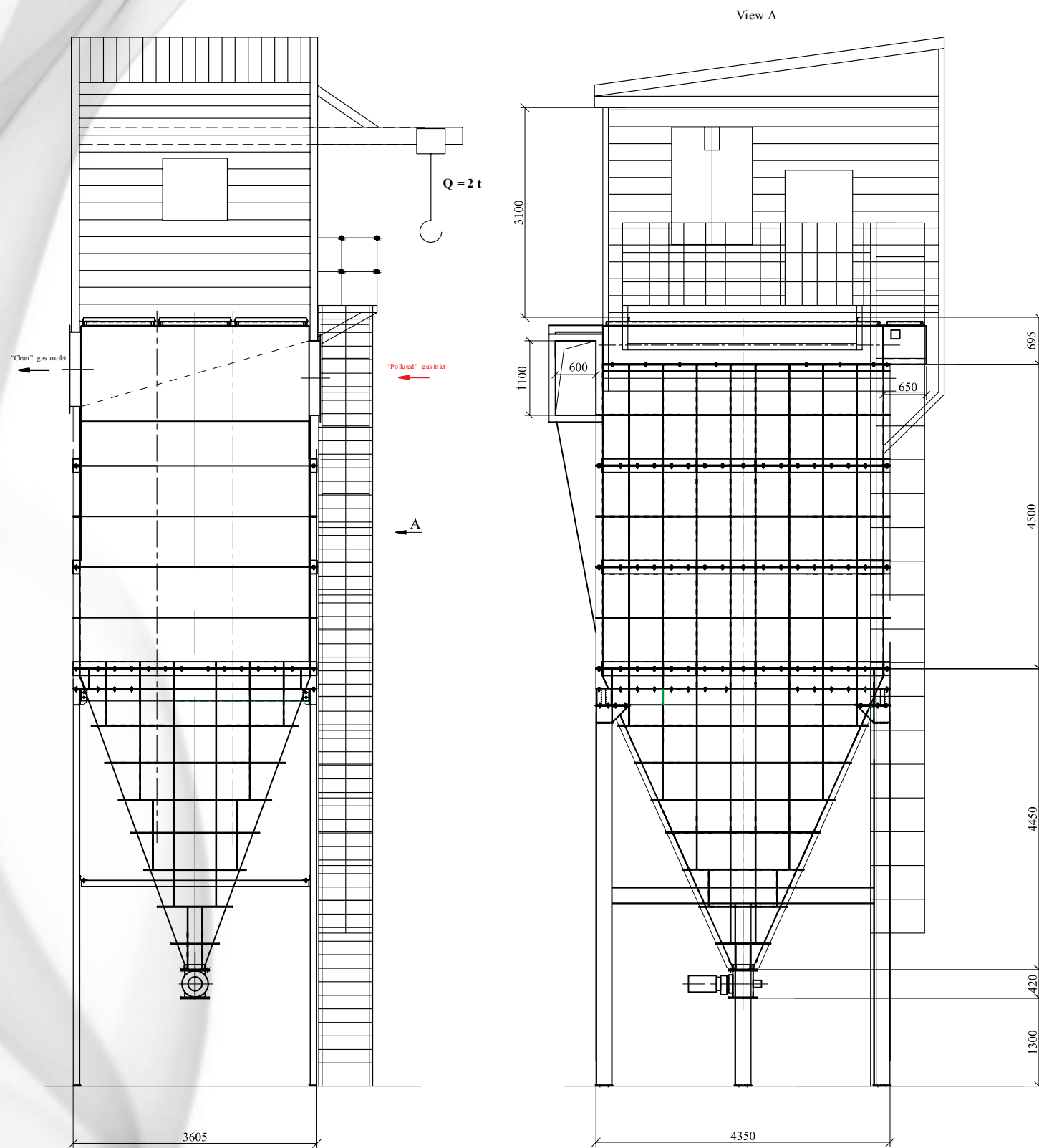

### SFS 75 225/3-4.5 Filter Specifications

Filter type	Capacity, m <sup>3</sup> /h	Bag length, m	Number of sections, pcs.	Filtration area, m <sup>2</sup>	Number of bags, pcs.
SFS 75 225/3-4.5	56,700	4.5	3	472.5	225

## General technical drawing of bag filter SFS 75 450/6-6.0

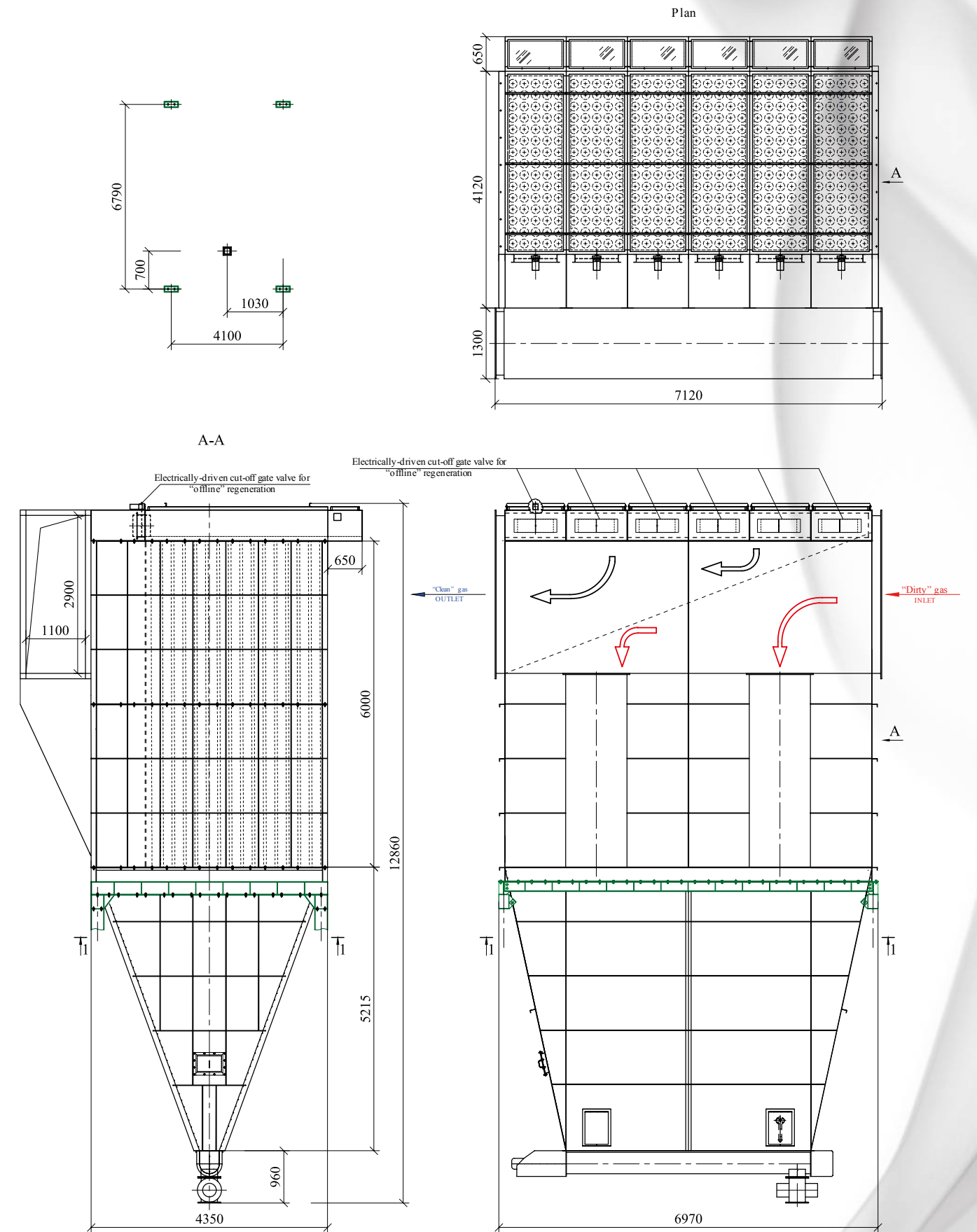

### SFS 75 450/6-6.0 Filter Specifications

Filter type	Capacity, m <sup>3</sup> /h	Bag length, m	Number of sections, pcs.	Filtration area, m <sup>2</sup>	Number of bags, pcs.
SFS 75 450/6-6.0	151,200	6.0	6	1,260	450

General technical drawing of bag filter SFS 75 1800/24-6.0

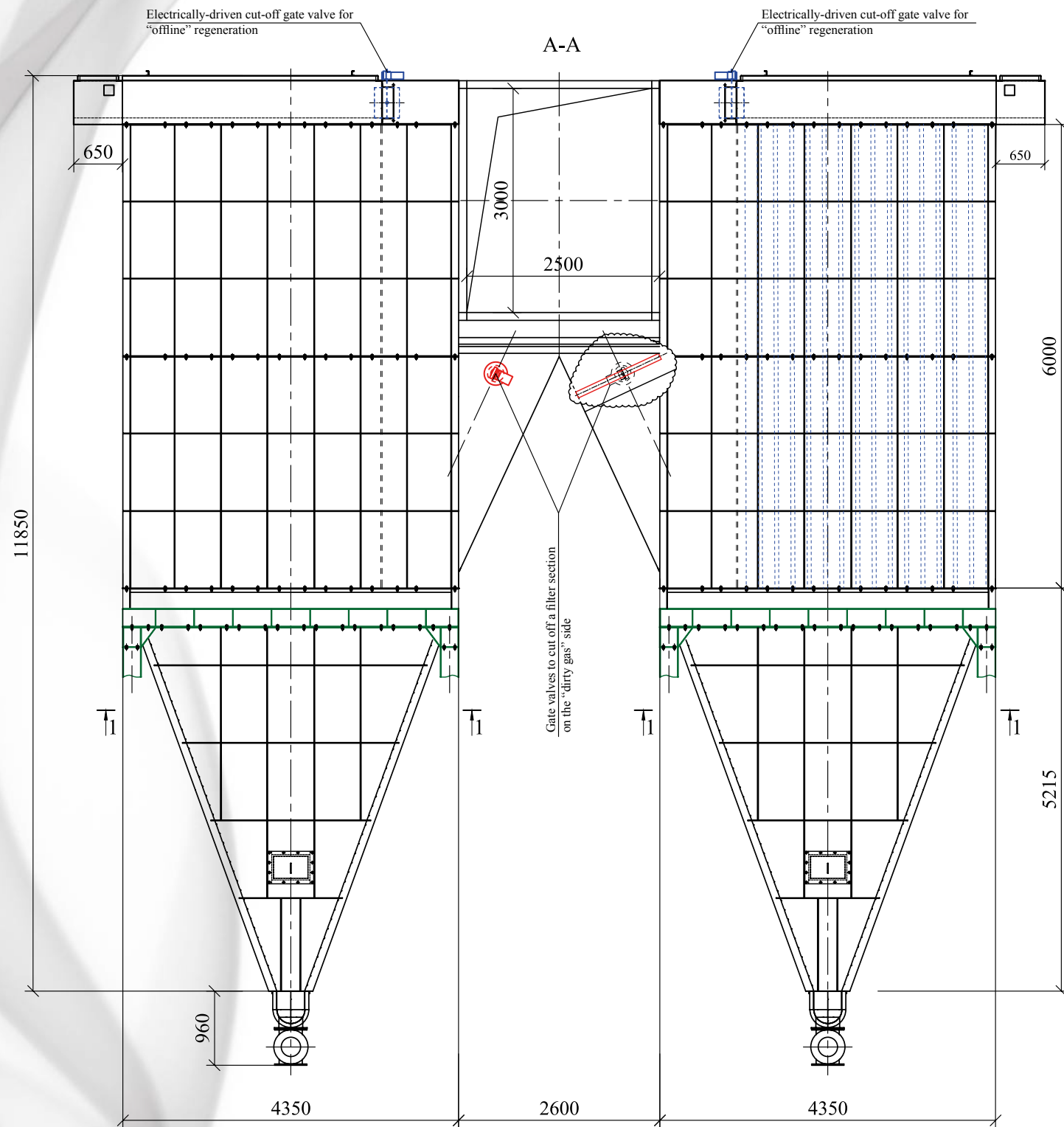

SFS 75 1800/24-6.0 Filter Specifications

Filter type	Capacity, m <sup>3</sup> /h	Bag length, m	Number of sections, pcs.	Filtration area, m <sup>2</sup>	Number of bags, pcs.
SFS 75 1800/24-6.0	604,800	6.0	24	5,040	1,800

General technical drawing of bag filter SFS 75 1800/24-6.0

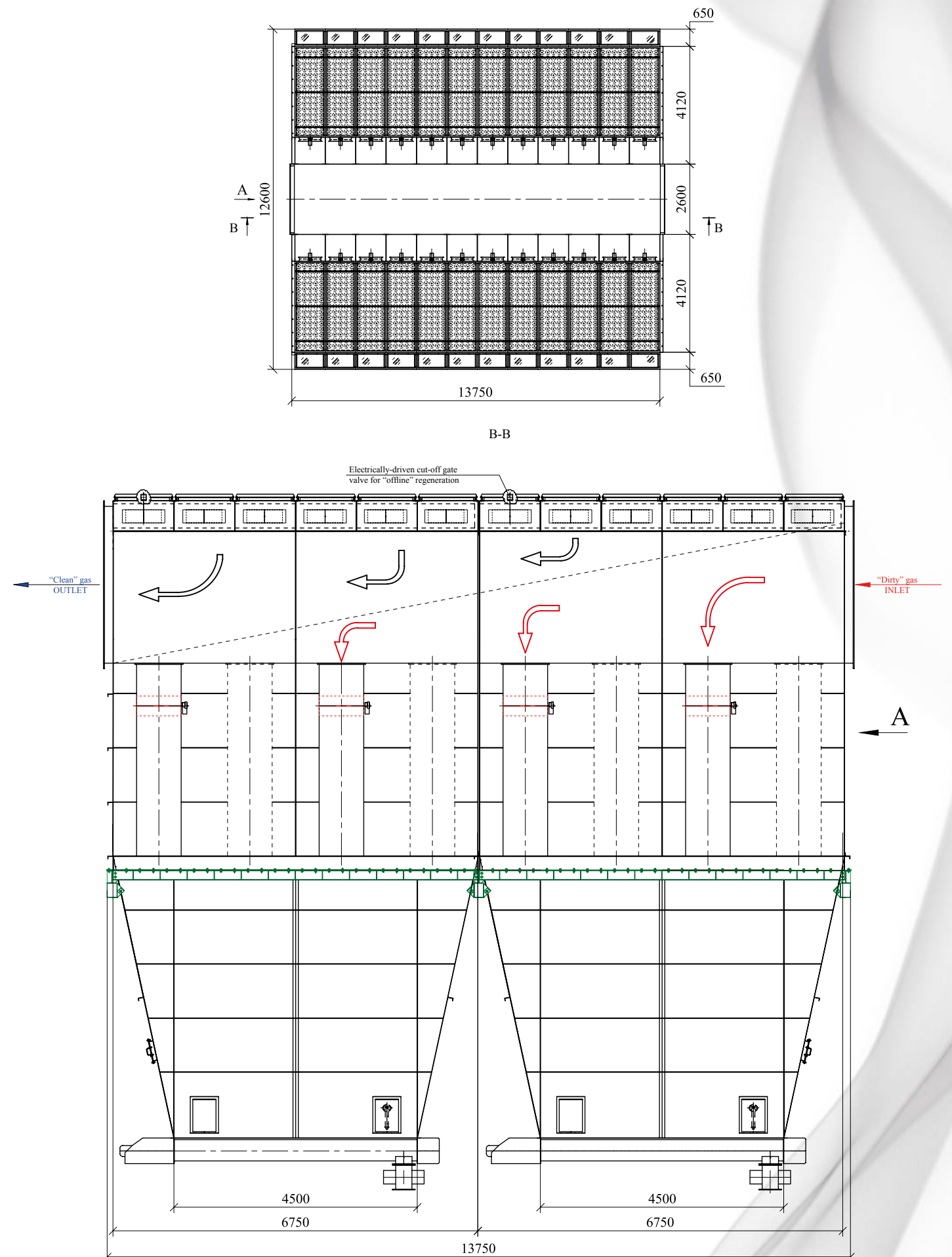

Technical characteristics and parameters of products listed in this catalogue may be changed without prior notice.



# SFB

Series



Silo pressure filter with cylindrical cartridges and pulse purge

# SFB Series Filters



## Description

SFB filters are a cost-effective solution for aspiration of silos loaded under overpressure. They are single-block automatic self-cleaning continuous-operation cartridge filters in a cylindrical body. Filtration surface area ranges from 15 to 27 m<sup>2</sup>. Polyester is typically used as filter fabric. Filters are regenerated by pulse purging with compressed air. Filters can be installed both indoors and outdoors, at an ambient temperature up to -40 °C.

## Industries

- Chemical
- Metallurgical
- Metal working
- Mining
- Food
- Machine building
- Production of construction materials
- Cement production

## Applications

SFB series filters are applied for aspiration of silos loaded under pressure. It releases cleaned air through itself out of the silo, relieving overpressure and thus performing the function of environmental care. SFB series filters are supplied fully assembled and are easy to install.

## Filter Elements

Filter element of a SFB filter is a cylindrical longitudinally pleated non-woven cartridge.



## Type of Filter Elements

Designation	Filtration surface, m <sup>2</sup>	Pocket material
CART-D-2.5-SFB	2.5	Polyester*
CART-C-2.5-SFB	2.5	Antistatic polyester
CART-T-2.5-SFB	2.5	Teflon (diaphragm)
CART-TC-2.5-SFB	2.5	Antistatic Teflon (diaphragm)
CART-D-3.0-SFB	3.0	Polyester*
CART-C-3.0-SFB	3.0	Antistatic polyester
CART-T-3.0-SFB	3.0	Teflon (diaphragm)
CART-TC-3.0-SFB	3.0	Antistatic Teflon (diaphragm)

\* Filter standard version.

Technical characteristics and parameters of products listed in this catalogue may be changed without prior notice.

## Summary Specifications of SFB Series Filters

Specifications	Filter brand			
	SFB-15 SFB-18	SFB-22 SFB-27	SFB-15-WP SFB-18-WP	SFB-22-WP SFB-27-WP
Number of cartridges, pcs.	6	9	6	9
Active filtration area with cartridge length: – 1,000 mm – 1,200 mm	15 m <sup>2</sup> 18 m <sup>2</sup>	22 m <sup>2</sup> 27 m <sup>2</sup>	15 m <sup>2</sup> 18 m <sup>2</sup>	22 m <sup>2</sup> 27 m <sup>2</sup>
Rated capacity with cartridge length:* – 1,000 mm – 1,200 mm	1,000 m <sup>3</sup> /h 1,300 m <sup>3</sup> /h	1,500 m <sup>3</sup> /h 2,000 m <sup>3</sup> /h	1,000 m <sup>3</sup> /h 1,300 m <sup>3</sup> /h	1,500 m <sup>3</sup> /h 2,000 m <sup>3</sup> /h
Residual concentration, mg/m <sup>3</sup>	≤ 10			
Power consumption, W	100	100	250	250
Noise level, dB	75 max			
Operation temperature, °C	-10 ÷ +40		-40 ÷ +40	
Compressed-air pressure (operating), bar	6			
Compressed-air consumption (under normal conditions), Nm <sup>3</sup> /h	3–4			
Compressed-air quality requirements: – Class under GOST 17433-80 – Class under ISO 8573-1	5 or higher (1, 2, 3, 4) 2–3 (oil and moisture are not permitted)			
Overall dimensions L x W x H, mm	1,118 x 982 x 1,554 (see the drawing below)			
Weight, kg	141	151	146	156

## Restrictions in the use of SFB filters (of series and piece production)

SFB series filters has no structural protection against explosion, and are not intended for the following types of dust:

- for smoldering and self-igniting dust;
- for fibrous dust;
- for sticky dust;
- for dust with moisture.



## SFB Filter Design

In terms of design, SFB series filter consists of a cylindrical body with a flap cover (see the figure below). The filter body is made of sheet steel and painted with high-quality powder paint to provide a high degree of protection of the filter body against environmental impacts. Filter elements are located inside the body, and a system is mounted under the flap cover. The purge system control unit is located on the side wall outside the filter. In ver-

sions designed for -40 °C, the control unit is insulated and heated from the inside, the receiver is made of stainless steel, and valves supplying compressed air for regeneration are equipped with frost-resistant diaphragms.

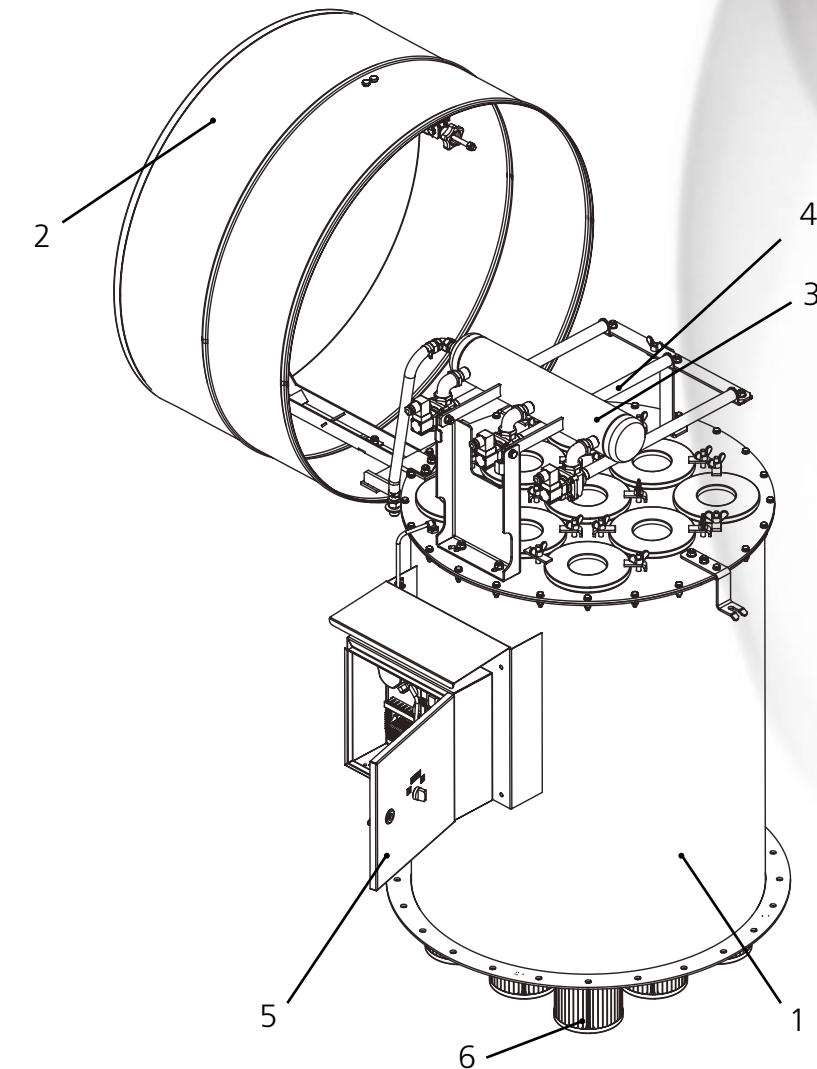

## Basic Elements of SFB Filter

- 1 – body
- 2 – flap cap
- 3 – receiver
- 4 – purge system
- 5 – control unit
- 6 – filter cartridge

### Standard delivery set

Filter body with flap cover

Purge system included:

- compressed-air receiver
- purge pipes
- control valves
- KF-2 control unit
- differential pressure sensor

CART-D-...-SFB or CART-C-...-SFB filter cartridges

Earthing line (for antistatic filters)

Control unit heating (version suitable for -40 °C)

Mounting flange (ordered separately)

### Additional configuration

Special filter cartridges

Dust collector with supports

Dust discharge and collection system

Fan

## Versions of SFB Filters (with SFB-22 as an example)

- Standard version; marking: **SFB-22**
- Antistatic version; marking: **SFB-22 ant**
- Frost-resistant version; marking: **SFB-22-WP**
- Antistatic frost-resistant version; marking: **SFB-22-WP ant**



## General technical drawing of SFB series filter

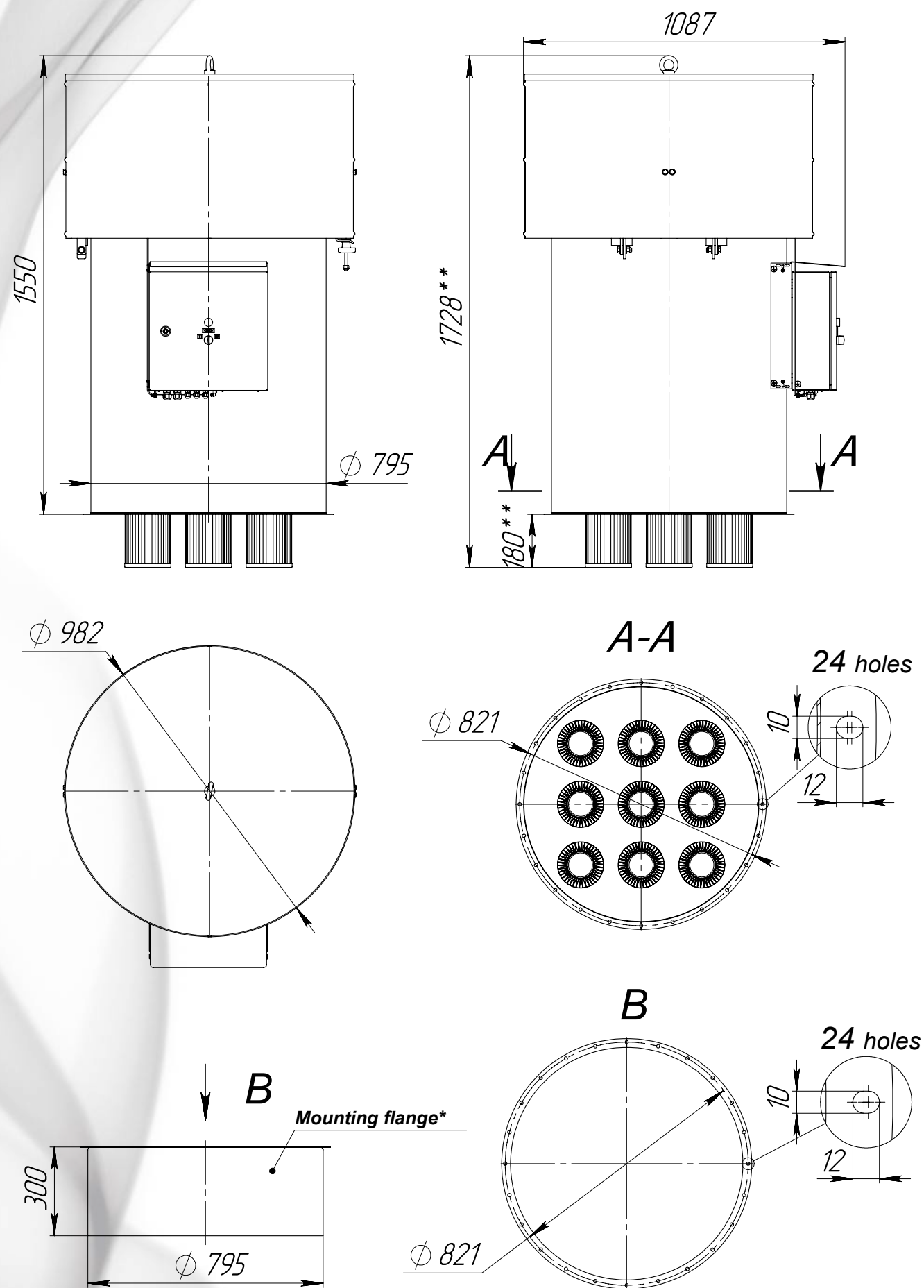

\* Mounting flange is ordered separately.  
 \*\* For cartridge 1,200 mm long.

Compressed air is supplied through a fitting with 1/2" male thread.

64 Technical characteristics and parameters of products listed in this catalogue may be changed without prior notice.

## Additional Filter Data

### Compressed-air requirements

Operating pressure of compressed air for regeneration should be at least 6 atm. (bar). Compressed air for regeneration of the entire filter model range (excluding filters with mechanical stirring) is divided into classes according to the table below (based on its possible use for filter regeneration).

Class	Compressed-air supply method	
	Directly to a filter	Through a pre-separator
1	Ideal	Ideal
2	Optimal	Optimal
3	Possible	Optimal
4	Undesirable*	Possible
5	Impossible	Undesirable*
6	Impossible	Impossible

\* To avoid malfunctions in solenoid valves.

Compressed air is divided into classes according to DIN ISO 8573-1 based on the following criteria:

Class	Content of impurities				
	Mechanical impurities		Moisture		Oil
	Particle size, $\mu\text{m}$ (max)	Density, $\text{mg}/\text{m}^3$ (max)	Dew point, $^{\circ}\text{C}$	Moisture content, $\text{mg}/\text{m}^3$	Residual oil content, $\text{mg}/\text{m}^3$
1	0.1	0.1	-70	3	0.01
2	1	1	-40	120	0.1
3	5	5	-20	880	1
4	15	8	3	6,000	5
5	40	10	7	7,800	
6			10	9,400	

Measurements are made at a pressure of 1 bar and a temperature of 20  $^{\circ}\text{C}$ .  
 For filters manufactured by SovPlym JSC, Class 2 air is optimal.

### Pre-separator

Filters of this series use a pre-separator with a mounting dimension of 1/2".

### Filter Painting

Filters of this series are normally painted in accordance with the following scheme: light gray top (RAL 7047) and dark gray bottom (RAL 7012). If piece production is required, other colors can be used.

### Dust Discharge Methods

SFN, SFL and SFM series filters are equipped with 60 and 100 liter drums with manual slide valves to discharge dust. If piece production is required, filters can be fitted with:

- double pendulous valves (flashers);
- rotary valves (lock feeders);
- screw conveyors.

65 Technical characteristics and parameters of products listed in this catalogue may be changed without prior notice.

# Filter Fans

If necessary, series filters can be additionally equipped with fans in case of their piece production. Fans can be both made by SovPlym and third-party manufacturers. Data on the use of SovPlym fans are given below.

## SovPlym fans for SFM, SFL, SFB and SFM filters

Filter type	Fan type	Version (fan mounting method)
SFN	FUA	Suspended
	FTEV	Floor-standing
	SIF	Floor-standing
SFL	FUA	Suspended
	FTEV	Floor-standing
	SIF	Floor-standing
SFB	FUA	Suspended
SFM	FUA	Suspended
	FTEV	Floor-standing

### Suspended Version

The suspended version of SFN, SFL and SFB filters assumes that clean gas exits sideways from the clean gas chamber, and the fan is mounted laterally in a horizontal position (with a motor to the side) on a special bracket.

An adapter is installed on top of SFM filters to release clean gas sideways or upwards. With sideways release, the fan is mounted horizontally on a special bracket on the filter side. With upward release, the fan is mounted vertically (with the motor upwards) directly on the outlet flange.

### Technical Data for Fan Selection

The fan is installed at the filter outlet for the filter to operate under vacuum. The fan is selected based on its capacity and pressure head. Fan capacity is directly related to required filter capacity, and its pressure head is selected based on the total value of filter resistance and resistance of network upstream of it. To choose a fan, filter resistance should be in the range of 1,500–2,000 Pa.

The "capacity/pressure head" ratio is selected according to a relevant diagram of fan aerodynamic characteristics.

### Floor-standing Version

In case of a floor-standing version, the fan is installed separately from the filter. The filter outlet flange is connected to the fan suction flange with an additional air duct.

Normally, SFB filters are not equipped with fans. If piece production is required, instead of a flap cover, the SFB filter may be fitted with an airtight head which allows to use it both in suspended and floor-standing versions.

## Aerodynamic Characteristics of FUA, FTEV Fans

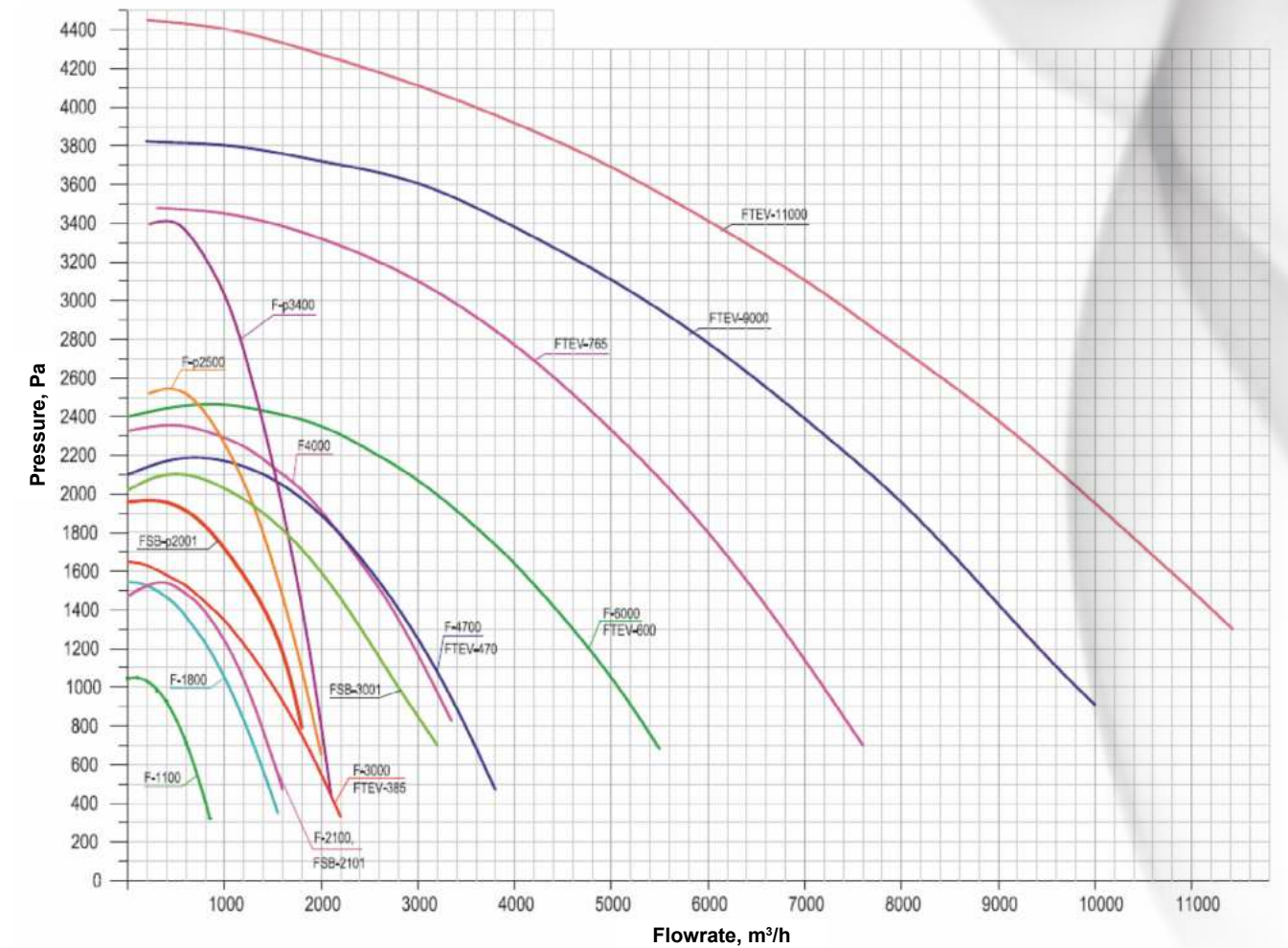

## Aerodynamic Characteristics of SIF Fans

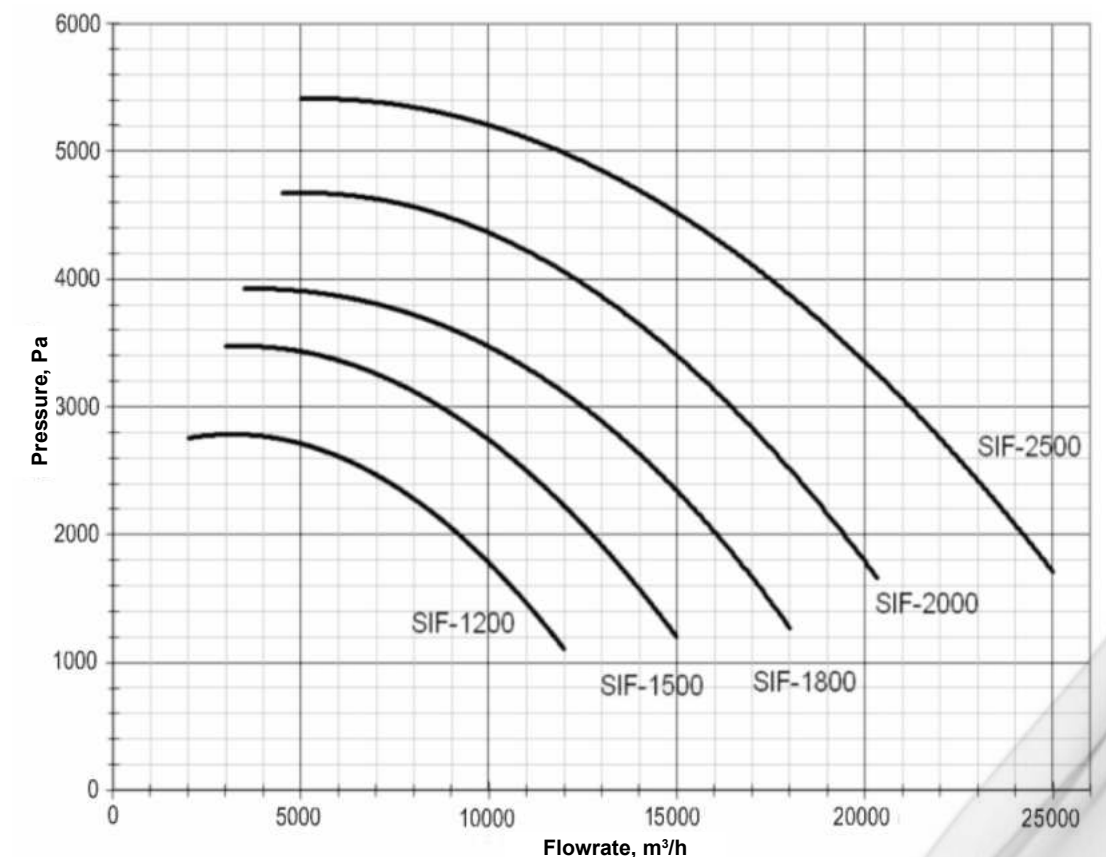



## Fan Specifications

Fan		Characteristics		Specifications		
Filter	Brand	Capacity, m <sup>3</sup> /h	Pressure head, Pa	Power, kW	Rotation speed, rpm	Weight, kg
FUA	FUA-1100	200–1,000	1,100–500	0.37	2,730	10
	FUA-1800	300–1,300	1,530–1,000	0.55	2,730	14.5
	FUA-2100	300–1,600	1,600–1,000	0.75	2,820	17.1
	FUA-2500	400–1,400	2,500–1,700	1.1	2,870	21
	FUA-3000	500–2,300	1,500–900	1.1	2,800	23
	FUA-3400	400–2,200	3,400–2,200	1.5	2,870	31
	FUA-4700	1,000–4,000	2,380–1,200	2.2	2,860	37
	FUA-6000	1,500–5,000	2,500–1,400	4.0	2,850	53
FTEV	FTEV-765	2,500–5,500	3,400–1,800	5.5	2,850	80
	FTEV-9000	3,500–9,000	3,600–2,000	7.5	2,910	150
	FTEV-11000	4,000–9,000	4,200–2,100	11.0	2,890	185
SIF	SIF-1200	2,000–12,000	2,800–1,100	7.5	2,910	113
	SIF-1500	3,000–15,000	3,500–1,200	11.0	2,890	168
	SIF-1800	3,500–18,000	3,900–1,300	15.0	2,930	215
	SIF-2000	4,500–20,000	4,700–1,700	22.0	2,940	280
	SIF-2500	5,000–25,000	5,400–1,800	30.0	2,940	311

# Checklist

## For Filter Equipment Selection, Page 1

### 1. Contact details

Customer:	Telephone/fax:
Contact:	E-mail:
Project name:	

### 2. Technical parameters

Description of cleaning task, process:		
Flow rate of gas to be cleaned (operating), m <sup>3</sup> /h:	Temperature of gas to be cleaned, °C:	
Dust pour density, t/m <sup>3</sup> :		
Input dust concentration, g/m <sup>3</sup> :		
Required residual concentration, mg/m <sup>3</sup> :	<input type="checkbox"/> Not more than 20 mg/m <sup>3</sup>	<input type="checkbox"/> Not more than 10 mg/m <sup>3</sup>
	<input type="checkbox"/> Your variant:	
Particle size, µm:		
Dust properties:	<input type="checkbox"/> Combustible	<input type="checkbox"/> Explosive
	<input type="checkbox"/> Hydroscopic	<input type="checkbox"/> Abrasive
	<input type="checkbox"/> Corrosive	<input type="checkbox"/> Electrostatic
	<input type="checkbox"/> Your variant:	
Dust chemical composition (substance):		
Gas component:		

### 3. Operational parameters

Filter location:	<input type="checkbox"/> Shop floor	<input type="checkbox"/> Outdoor
Ambient temperature, °C:		
Compressed-air availability (5–6 bar, purity class 2–3 under ISO 8573-1):	<input type="checkbox"/> Yes	<input type="checkbox"/> No
Filter operation mode:	<input type="checkbox"/> By shifts	<input type="checkbox"/> Continuous
	<input type="checkbox"/> Your variant:	

### 4. Structural parameters

Filter version:	<input type="checkbox"/> standard	<input type="checkbox"/> antistatic	<input type="checkbox"/> explosion-proof	<input type="checkbox"/> chemically stable
Heat insulation (if necessary):	<input type="checkbox"/> with heat insulation and regeneration system heating			
	<input type="checkbox"/> filter heat insulation			
	<input type="checkbox"/> bunker heating			
Explanation:				
Fan configuration	<input type="checkbox"/> Free standing	<input type="checkbox"/> Built-in	<input type="checkbox"/> None	
Total resistance of network upstream of a filter (if it is equipped with a fan), Pa:				
Filter color:	<input type="checkbox"/> Bottom – RAL 7012, top – RAL 7047 (standard colors)		<input type="checkbox"/> Your variant, please indicate color using RAL scale:	
Restrictions of filter installation place overall dimensions, mm:	Length x width x height			
Dust discharge method:	See bunker configurations			
	<input type="checkbox"/> Your variant:			





- Offices
- Dealerships



**SovPlym JSC**

195279, St. Petersburg,  
shosse Revolyutsii, 102, bldg. 2  
tel./fax: +7 (812) 33-500-33  
e-mail: info@sovplym.spb.ru  
www.sovplym.ru

**Moscow Office**

111020, Moscow  
Kryukovskaya Str., 23  
tel./fax: +7 (495) 121-06-56  
e-mail: msk@sovplym.com

**Ekaterinburg Office**

620078, Ekaterinburg  
Comintern Str., bld. 16, of. 311  
tel./fax: +7 (343) 356-52-33  
e-mail: ekb@sovplym.com

**Surgut Office**

628400, Tyumen Region, Surgut,  
50 years of VLKSM Str., 4/2  
tel./fax: +7 (3462) 55-58-35  
e-mail: sgt@sovplym.com

**Nizhny Novgorod Office**

603034, Nizhny Novgorod  
Schlusselburg Str.,  
23 "B", of. 41  
tel./fax: +7 (831) 216-44-40  
e-mail: nnn@sovplym.com

**Samara Office**

443125, Samara  
Gubanov Str., bld. 3, of. 502  
tel./fax: +7 (846) 205-99-63  
e-mail: sam@sovplym.com

**Kazan Office**

421001, Russia, Kazan,  
Sibgat Hakim Str., bld. 31, P.O.Box 113  
tel.: +7 (843) 520-70-70, 202-07-30  
kazan@sovplym.spb.ru

**Rostov Office**

344064, Rostov-on-Don  
Vavilov Str., bld. 62-B, of. 315  
tel./fax: +7 (863) 282-92-92  
e-mail: rnd@sovplym.com

**SovPlym-Sibir LLC**

630009, Novosibirsk  
Nikitin Str., bld. 20  
tel./fax: +7 (383) 335-85-86  
e-mail: sovplym@sovplym.ru

**SovPlym-Kazakhstan LLP**

100017, Karaganda  
Ave. N. Abdirrov, bld. 3, of. R-316  
tel./fax: +7 (7212) 42-57-74  
e-mail: kz@sovplym.ru

**SovPlym JV LLC**

100047, Tashkent  
Mirzo-Ulugbeksy District, O'ZBEKIS-  
TON OVOZI KO'CHASI, 2-UY  
tel./fax: +998-71-113-00-11  
e-mail: info.uzb@sovplym.com

**www.sovplym.ru**  
**8 (800) 555-83-03**