

LOCAL EXTRACTION VENTILATION SYSTEMS

Product catalogue 2020

About company

"SovPlym" Ltd manufactures equipment for air cleaning at industrial factories and beyond in order to improve the quality of labor conditions health of workers and ecological situation.

We are the leaders of local extraction ventilation systems for over 30 years. Since foundation in 1989 we have solved many various tasks on cleaning the air at heavy industry's plants, processing industry factories, food and other industrial facilities.

Over such a long time period we learned not only to manufacture efficient serial equipment for standard industrial processes, but also we have a large experience in solving non standard tasks on air cleaning at industrial facilities.



600

total number of employees at SovPlym



2

manufacturing plants in St.-Petersburg and Ekaterinburg



20 000 m²

total area of manufacturing and warehousing facilities

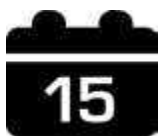

15 days

manufacturing time for standard products



300

unique articles of products (over 200 manufactured in house)



14

branches in Russia and abroad

Manufacturing

Year 2019 was very important for SovPlym because of increasing the manufacturing capacity and significant relocation of production facilities into the new, modern workshop of 20.000 square meters, where the new set of technological machinery was started.

All manufactured products are produced only of high quality components and passes 100% quality control. Factory is working in accordance with integrated management quality control system, as per ISO 9001-2015 standard. Except control of manufactured products, there is a strict control of all purchased materials, parts and components used in the manufacturing process. The factory works in accordance with carefull production system, including rational work space organization "5S".



Customers choose us, because:

- We are customer oriented: for 30 years of our work, we put the task of solving customer's needs in first place
- We have our own factory of 20.000 square meters with highly technological set of equipment and machinery
- We manufacture high quality equipment and we are not afraid of complicated projects
- We have over 30.000 customers, among which are "Gazprom", "Rosteh" corporation, "RosAtom", Russian railroads and many other important companies and corporations of our country
- We work in all regions and time zones of the world. Large network of our branches and dealers across the country and abroad simplifies contact with end users
- We are experts in our work and use only modern technologies and up to date scientific knowledge in the field of air filtration, aspiration, high vacuum technologies, noise and spark protection and other innovations.



- Branches
- Dealers

Partners

Except our own manufacturing, SovPlym is an exclusive representative of well known worldwide manufacturers of equipment for various ventilation systems, air treatment and cleaning, aspiration and dust removal, environmental control and protection systems, metal cutting and other industrial tasks.

PLYMVENT®

vanad®
CNC Thermal Cutting Machines

Sibilia
industrial vacuums

FILTERMIST

PURAFIL



CIMBRIA

РУССКИЕ ШЛАНГИ

СЕПРО®
защитные ограждения

Engineering, installation and maintenance

SovPlym Ltd conducts all project works, as well as works on designing, development of equipment and technological process, installation of ventilation, aspiration, gas cleaning and geneneral cleaning systems.

Project works:

Own project department chooses and makes projects on efficient solutions for wide range of industrial processes and offers turn key solutions.

Complete solutions include following works:

1. Pre-project audit:
 - Examination of facilities;
 - Collection of initial data;
 - Creation of technical assignment;
2. Project:
 - Development of project documentation, determining major technical solutions;
 - Development of working documentation with basic set of design drawings, certification of equipment and materials, required for manufacturing, along with construction and installation works;
3. Receiving of necessary aprovements for passing the expertise;

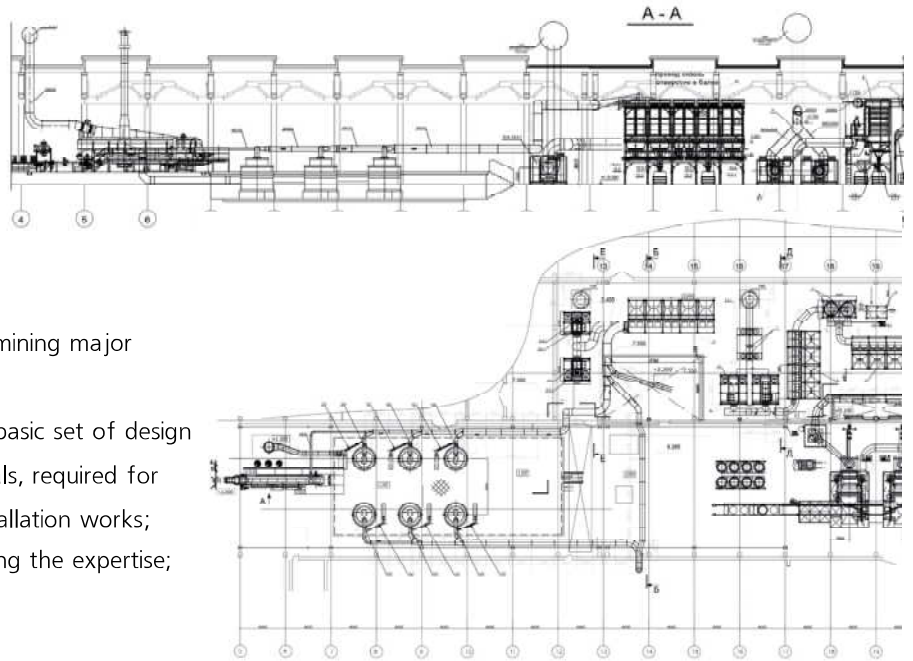

Development of equipment

Development of equipment is done in 3-d designing software «SolidWorks» with usage of aerodynamic flows calculation module «Flow Simulation». Except that, we use AutoCAD, 3DS MAX and Revit software for creation of BIM projects.

Each unit passes following stages:

1. 3D designing;
2. Durability and aerodynamic calculations;
3. Issuing working design documentation;
4. Issuing service documentation;
5. Laboratory tests.



Installation and maintenance

SovPlym Ltd is a participnt of several professional project, construction and research organizations. We offer full range of works on installation and maintenance

1. Author's supervision;
2. Installation supervision;
3. Installation works;
4. Start-up works;
5. Warranty and maintenance services;

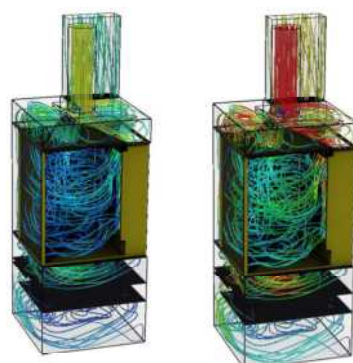



Table of contents

1. REVIEW OF INDUSTRIAL OPERATIONS	6
Welding, cutting, grinding	
2. EXTRACTION ARMS	8
Table top extraction arms	
Telescopic extraction arms	
Lifting-rotary extraction arms	
Installation accessories	
3. DUST COLLECTORS, CYCLONES, SEPARATORS	26
Direct flow cyclones	
Block of cyclones	
Extraction panels	
Dust collectors	
4. FILTRATION PRINCIPLES	34
Types of air filters	
Major types of replaceable filtration elements	
Special features of materials, used for cartridges of self-cleaning filters	
5. MOBILE FILTRATION UNITS	40
Portable filters	
Mechanical self-cleaning filters	
Electrostatic filters	
6. STATIONARY FILTERS	54
Wall mounted filters	
Modular self-cleanign filters	
Push-Pull systems	
Diluter systems	
Mechanical accumulative filters	
Ion exchange filtration modules	
7. OIL MIST FILTERS	89
Mechanical filters	
Modular filters	
8. RADIAL FANS	98
9. AUTOMATIC CONTROL SYSTEMS	106
10. WELDING AND THERMAL CUTTING TABLES	110
APPENDIXES	122
Calculation of extration system	
Questionnaires	



1. Welding, cutting, grinding of metal

SAMPLE OF EQUIPPING OF VARIOUS TECHNOLOGICAL WORK PLACES AT INDUSTRIAL FACTORY WITH THE HELP OF FILTRATION AND HIGH VACUUM EQUIPMENT, ALONG WITH PROTECTIVE AND NOISE REDUCING PARTITIONS FOR ORGANIZATION OF COMMON WORK SPACE.

NAVIGATOR	page
Extraction arms.....	8
Dust collectors, cyclones, separators.....	26
Mobile filters.....	40
Stationary filters.....	54
Fans.....	98
Welding and thermal cutting tables.....	110

THERMAL CUTTING (GAS, PLASMA, LASER)

1. Modular extraction table (CCT) for thermal cutting 3x10m (2 rows x 5 basic modules). Fumes are being extracted directly through table top.

GENERAL CLEANING (PREMISES AND EQUIPMENT)

2. General cleaning of premises and equipment is done with the help of various end pieces, connected with hoses to valves, installed on central duct. Connective ducts between valves and central duct are made in the places of allocation of large amount of dust and chips. Also, one welding robot is also connected to high vacuum module.
3. Centralized high vacuum system.

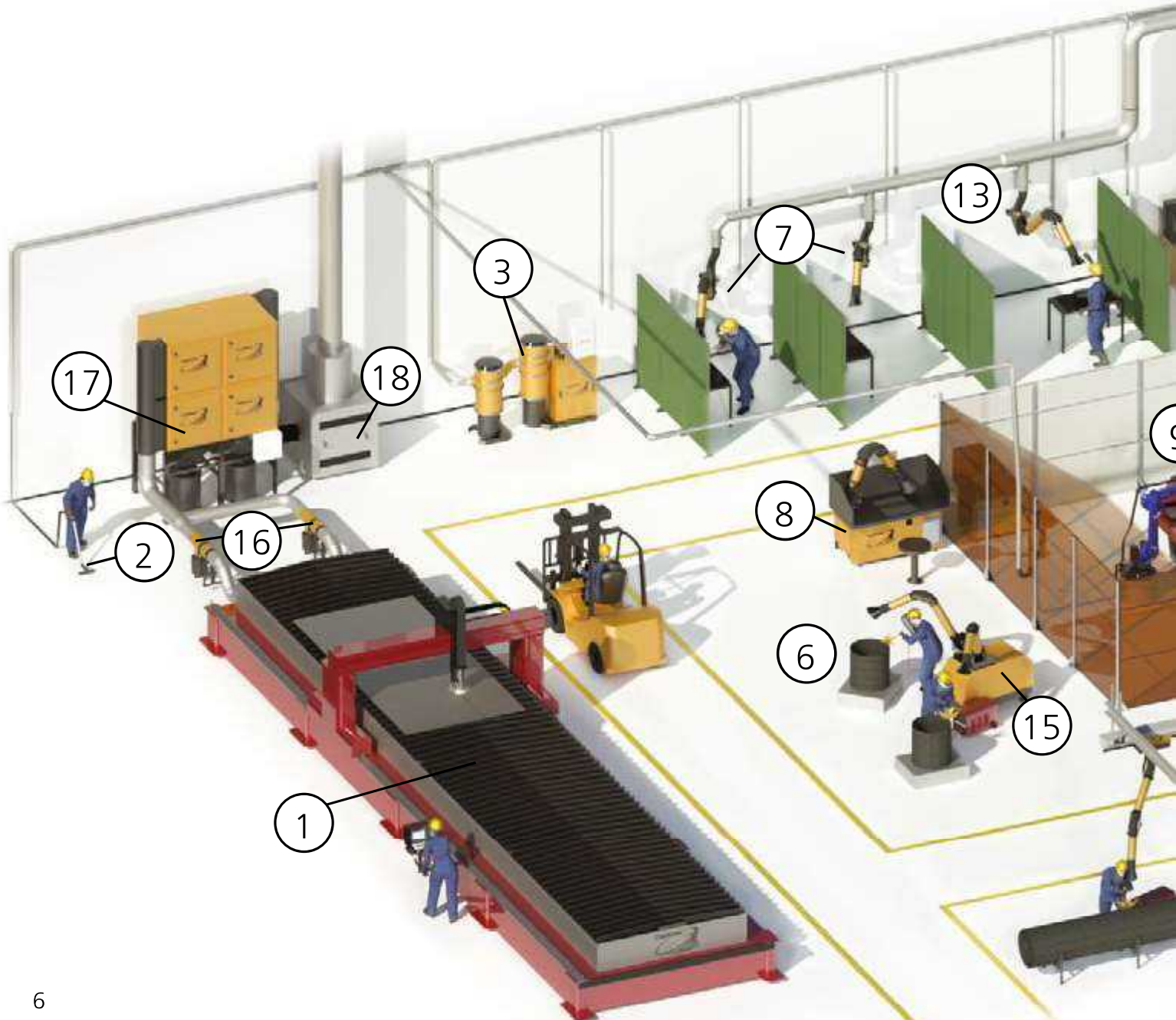

WELDING

4. Welding zone for long, oversized parts. Serviced by rail system with several extraction arms BEA-M-3H on sliding carriages.
- 5,10 Welding zone for oversized parts. Serviced by console rotary extraction arms EF-M-3530.
6. Temporary welding work place. Serviced by mobile filter DCSC-M
- 7,13 Welding zones for small parts. Serviced by extraction arms BEA-M-3H, connected to centralized extraction system.
8. Welding work place, equipped with welding table WT-CCM with integrated extraction arm and self-cleaning filter.

ROBOTIC WELDING

9. Extraction of welding fumes, directly from torch.

CUTTING/GRINDING

11. Oversized part grinding area. Services by extraction panel SVP-5000, connected to self-cleaning filter DCSC-S.
12. Sharpening machine, connected to dust collecting unit PU with manual shaking of sleeves for cleaning.
14. Small parts grinding station. Equipped with welding-grinding extraction table CCZ-2500
15. Mobile self-cleanign filter DCSC-M6 for welding and grinding at temporary work places

FILTERS/FANS

16. Direct flow cyclone CPO-4000 for capturing of coarse dust particles, sute and sparks.
17. Modular self-cleaning filter DCSC-S-16.
18. Central fan in noise reduction jacket HPF-1500.
19. Dust collecting unit PU, equipped with VMA fan.
20. Modular self-cleaning filter DCSC-S-12-V.
21. Wall mounted self-cleaning filter DCSC-W-2x160 with integrated fan in noise reduction jacket.
22. Modular self-cleanign filter DCSC-S-4.
23. FD series extraction fan, specially designed for installation directly on self-cleaning filters DCSC-S.

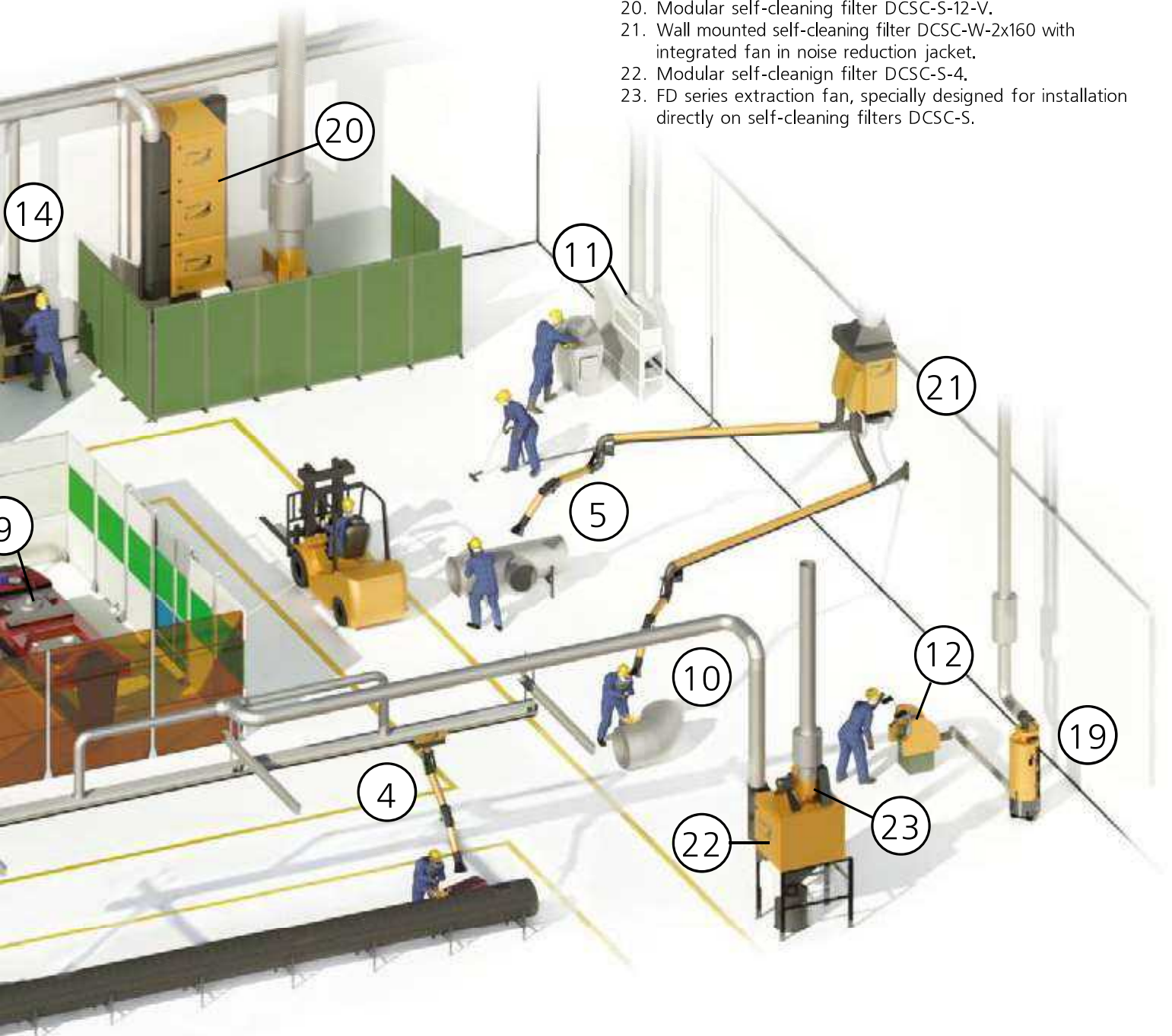

2 EXTRACTION ARMS



page 9

LamArm

Table top extraction arm for removal of fumes from soldering, chemical vapours and dust.



page 12

WBA-2

Compact telescopic extraction arm for removal of welding fumes, oil mist, dust and other pollutants at small work places and in premises with low ceilings.



page 14

BEA-M

Lifting-rotaty extraction arm Ø160mm for removal of welding fumes, oil mist, dust and other pollutants.



page 16

BEA-200

Lifting-rotaty extraction arm Ø200mm for removal of welding fumes, oil mist, dust and other pollutants.



page 18

EF-M

Console lifting-rotaty extraction arm Ø160 for removal of welding fumes, oil mist, dust and other pollutants.



page 20

EF-200

Console lifting-rotaty extraction arm with increased capacity Ø200mm for removal of welding fumes, oil mist, dust and other pollutants.



page 22

EC

Console lifting-rotaty extraction arm Ø160mm with vertical telescopic mechanism for removing of welding fumes and similar types of smoke.



page 24

Accessories

Support columns for installation of extraction arms on the floor in any part of the work shop.

LABARM | TABLE TOP EXTRACTION ARM



Description

Table top extraction arm for removal of smokes and fumes from soldering, light welding, chemical vapours, oil mist, dust and similar hazardous substances. Depending on the model, arm may be fixed to the table or wall (or support pole sPA) with special bracket. See accessories section part "Support poles and columns" on page 24).

Application

- Electrotechnical industry
- Pharmaceutical industry, tooth prosthetics
- Food industry
- Chemical industry
- Precise machine building
- Jewelry factories
- Renovation labs
- Educational institutions

Features and advantages

- Hollow duct design
- Various mounting options
- Large variety of sizes
- Gas shock absorber
- Integrated damper
- Two types of hoods (for LabArm-75 model)
- Table mounting bracket (for LabArm-75)
- Durable design

Technical parameters

Article	Model	Length max. m.	Ø Diameter, mm	Recommended air flow, cmh	Recommended installation height, m
5383	LabArm-75-07	0,7	75	125 - 250	0,7 – 1,0
5347	LabArm-75-10S	1,0	75		
5349	LabArm-75-15S	1,5	75		
5348	LabArm-75-10H	1,0	75		
5350	LabArm-75-15H	1,5	75		
5381	LabArm-100-15S	1,5	100	250 -500	0,7 – 1,0
5382	LabArm-100-15H	1,5	100		
5384	LabArm-125-2S	2,0	125	500 - 700	1 – 2,0
5385	LabArm-125-3S	3,0	125		
5386	LabArm-125-2H	2,0	125		
5387	LabArm-125-3H	3,0	125		

Pressure drop diagram

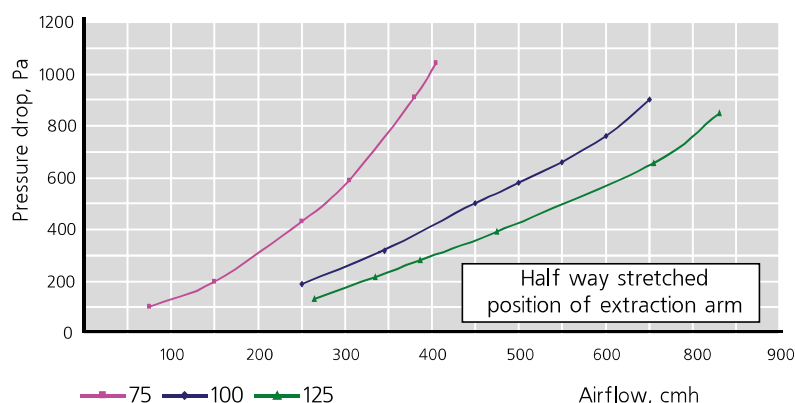

Types and dimensions of extraction arm LabArm-75-07 (short version)

Type S (mounting over bracket)

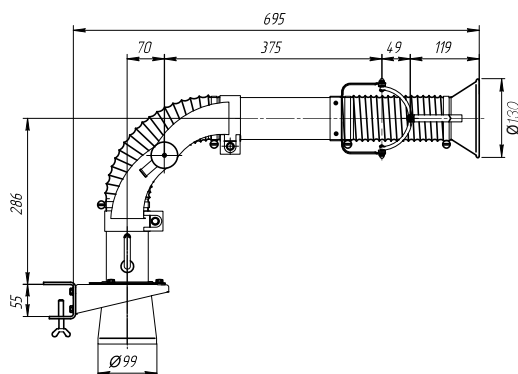

Type H (mounting under bracket)

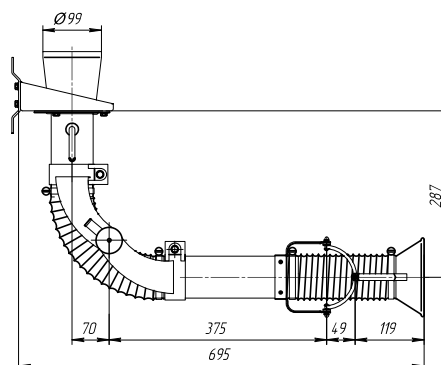

Delivery set/mounting options

Model	Positioning at the bracket. Mounting options.	Delivery set
LabArm-75-07	<p>Above or under the bracket (universal)</p> <ol style="list-style-type: none"> 1. Mounting on the wall or similar vertical surfaces or supports with the help of the bracket. 2. Mounting to the table edge with the clamp. 3. Mounting to the horizontal surface after cutting out the hole (bracket and clamp are not being used). 	<ol style="list-style-type: none"> 1. Two types of nozzles: round conical and straight. 2. Wall mounting bracket. 3. Clamp for the table edge mounting. 4. Regulating damper. 5. Without gas shock absorber.
LabArm-75-10S	<p>Above the bracket</p> <ol style="list-style-type: none"> 1. Mounting to the table edge with the clamp and bracket. 	<ol style="list-style-type: none"> 1. Two types of nozzles: – round conical $\varnothing 130$ mm; – straight $\varnothing 75$ mm. 2. Wall mounting bracket. 3. Clamp for the table edge mounting. 4. Regulating damper. 5. Gas shock absorber.
LabArm-75-15S	<ol style="list-style-type: none"> 2. Mounting to the horizontal surface after cutting out the hole (bracket and clamp are not being used). 3. Mounting on the wall or similar vertical surfaces or supports with the help of the bracket. 	
LabArm-75-10H	<p>Under the bracket</p>	
LabArm-75-15H	<ol style="list-style-type: none"> 1. Mounting on the wall or similar vertical surfaces or supports with the help of the bracket. 	<ol style="list-style-type: none"> 1. Two types of nozzles: – round conical $\varnothing 130$ mm; – straight $\varnothing 75$ mm. 2. Wall mounting bracket. 3. Regulating damper. 4. Gas shock absorber.
LabArm-100-15S	<p>Above the bracket</p> <ol style="list-style-type: none"> 1. Mounting to the horizontal surface after cutting out the hole (bracket and clamp are not being used). 2. Mounting on the wall or similar vertical surfaces or supports with the help of the bracket. 	<ol style="list-style-type: none"> 1. Round conical nozzle $\varnothing 200$ mm. 2. Wall mounting bracket. 3. Regulating damper. 4. Gas shock absorber.
LabArm-100-15H	<p>Under the bracket</p> <ol style="list-style-type: none"> 1. Mounting on the wall or similar vertical surfaces or supports with the help of the bracket. 	
LabArm-125-2S	<p>Above the bracket</p> <ol style="list-style-type: none"> 1. Mounting to the horizontal surface after cutting out the hole (bracket and clamp are not being used). 	<ol style="list-style-type: none"> 1. Round conical nozzle $\varnothing 230$ mm. 2. Wall mounting bracket. 3. Regulating damper. 4. Gas shock absorber. (1 or 2 pcs.).
LabArm-125-3S	<ol style="list-style-type: none"> 2. Mounting on the wall or similar vertical surfaces or supports with the help of the bracket. 3. Mounting on the floor, wall or ceiling with support pole sPA-110 or sPA-220. 	
LabArm-125-2H	<p>Under the bracket</p>	
LabArm-125-3H	<ol style="list-style-type: none"> 1. Mounting on the wall or similar vertical surfaces or supports with the help of the bracket. 2. Mounting on the floor, wall or ceiling with support pole sPA-110 or sPA-220. 	

Types and dimensions of LabArm-75-10S (H) and LabArm-75-15S (H) extraction arms

Type H (mounting under the bracket)

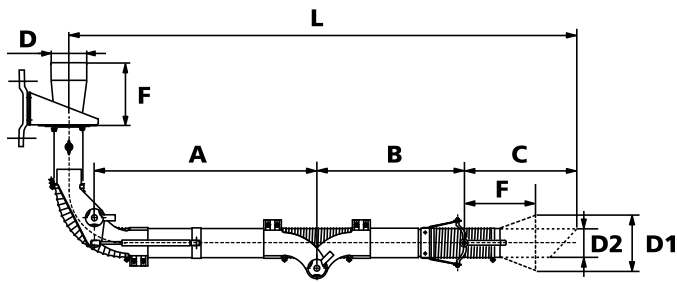

Type S (mounting over the bracket)

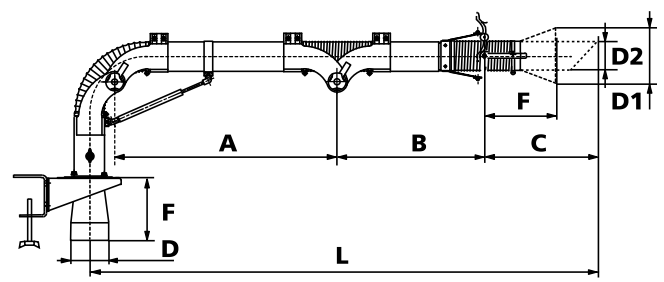

Universal support with bracket for extraction arms
LabArm-75-07S(H), LabArm-75-10S (H), LabArm-75-15S (H)

Universal support with bracket

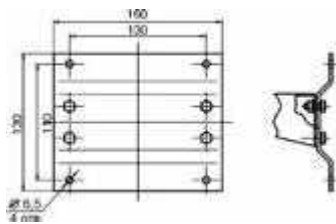

Clamp with bracket

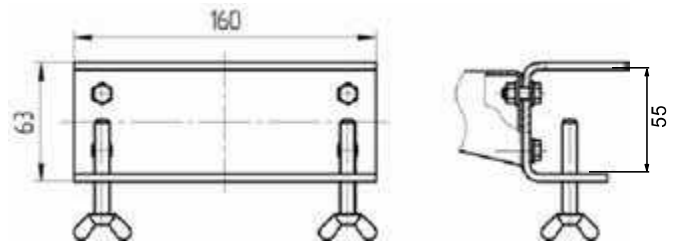

Type	L, mm	A, mm	B, mm	C, mm	D, mm	D1, mm	D2, mm	E, mm	F, mm
LabArm-75-10S	1275	542	424	241	100	130	75	152	115
LabArm-75-15S	1565	622	634	241	100	130	75	152	115
LabArm-75-10H	1275	542	424	241	100	130	75	153	115
LabArm-75-15H	1565	622	634	241	100	130	75	153	115

Dimensions of LabArm-100-15S (H), LabArm-125-2S (H) and LabArm-125-3S (H) extraction arms

Type H (mounting under the support)

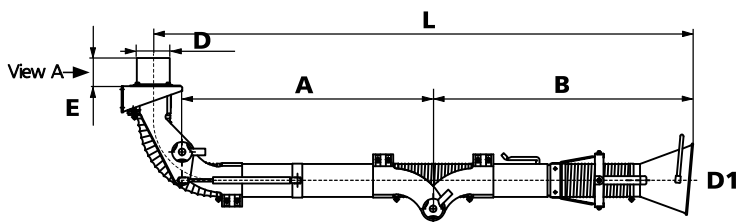

Type S (mounting over the support)

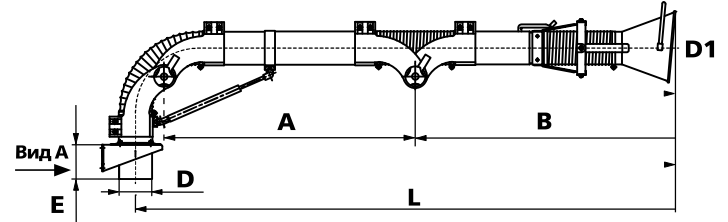

Bracket (view A)

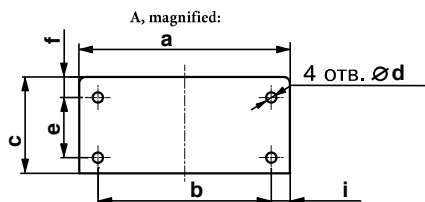

Type	L, mm	A, mm	B, mm	D, mm	D1, mm	E, mm	a, mm	b, mm	c, mm	d, mm	e, mm	f, mm	i, mm
LabArm-100-15S	1670	749	836	100	200	100	175	144	80	8,5	50	17	15,5
LabArm-100-15H	1670	749	836	100	200	100	175	144	80	8,5	50	17	15,5
LabArm-125-2S	2000	929	641	125	230	100	310	270	140	13	100	20	20
LabArm-125-3S	2000	929	641	125	230	100	310	270	140	13	100	20	20
LabArm-125-2H	3000	1458	1113	125	230	100	310	270	140	13	100	20	20
LabArm-125-3H	3000	1458	1113	125	230	100	310	270	140	13	100	20	20

WBA-2 | TELESCOPIC EXTRACTION ARM



Description

Compact telescopic extraction arm for removal of welding fumes and similar types of smoke. Convenient and durable telescopic mechanism provides precise positioning and support of the arm. Ideal for small work places and premises with low ceilings.

Intended use

- Training classes
- Welding workshops
- Chemical industry
- Jewelry manufacturing
- Electronics industry

Features and advantages

- Telescopic design
- Various mounting options
- Very compact
- Integrated damper for airflow regulation
- Easy and convenient positioning
- Mechanism do not require regular maintenance

Technical parameters

Article	Model	Length, m	Ø Diameter, mm	Recommended airflow, cmh	Installation height, m
5388	WBA-2	2	160	800 - 1200	2,2 – 3

Pressure drop diagram

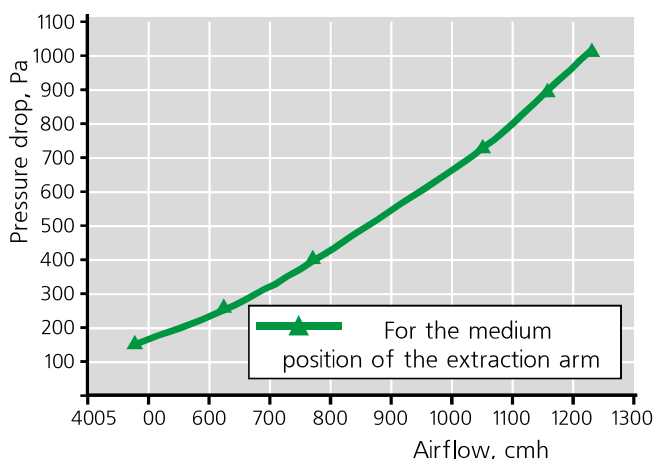

Reach radius

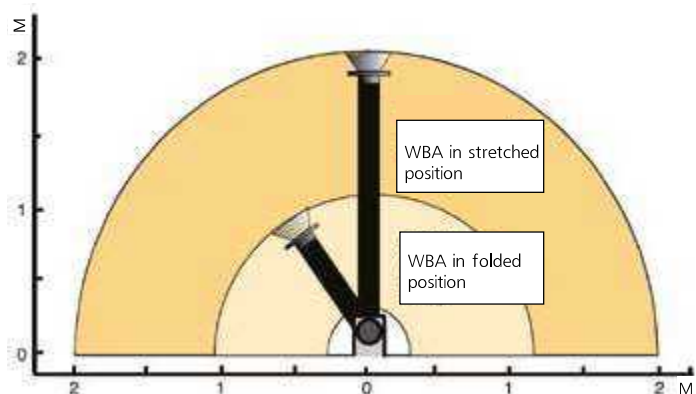

Installation options



1. On the floor, on sPA-220 support pole with fan on standard bracket;
2. On the wall, on the sPA-110 or sPA-220 support pole;
3. On the wall
4. On the ceiling, on the support pole sPA-110 or sPA-220 with fan on the standard bracket.

Dimensions

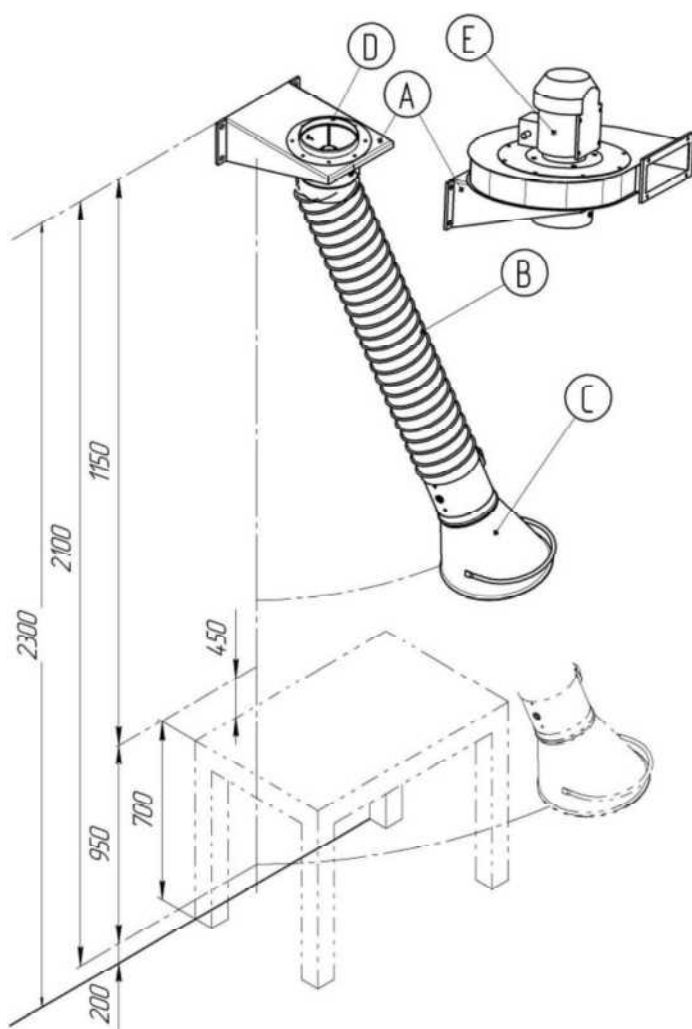

- A – Wall mounting bracket
- B – Telescopic part
- C – Funnel
- D – Flange
- E – Fan VMA-1800/2100 (option)

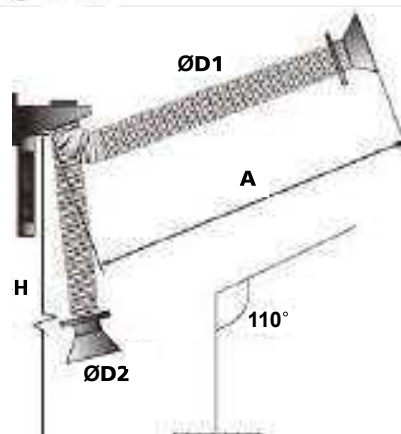
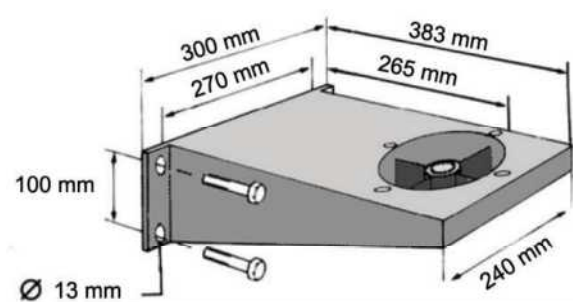

Model	Size, mm					
	A		H		D1	D2
	Minimum length	Maximum length	Minimum height	Maximum height	Hose diameter on telescopic part	Exhaust funnel diameter
WBA-2	1000	2000	2200	3000	160	300

BEA-M

LIFTING-ROTARY
EXTRACTION ARM



Description

Lifting-rotary extraction arm BEA-M is designed for removal of various types of smoke, dust, gases, aerosols and other harmful substances from local source of allocation. Duct diameter - 160mm.

Intended use

- Welding, metal processinga
- Food industry
- Precise machinery
- Ship building
- Car manufacturing
- Training classes

Features and advantages

- Hollow duct design
- Protective net in extraction nozzle
- Gas shock absorbers
- Integrated damper
- Wide range of models
- Rigid and durable design
- Set of working light (optional): halogen 20W lamp, two buttons on the nozzle to switch on light and fan, cable 4x0.5 L=10m (see pic. on page 15)
- Connection set: flexible hose Ø160mm, L=1,35m, hose clamp Ø160mm - 2pcs

Technical parameters

Article	Model	Length, m	Ø Diameter, mm	Recommended airflow, cmh	Installation height, m	L, mm	L1, mm	L2, mm	Weight, kg
5359	BEA-M-2S	2	160	1000-1200	1-2	1840	713	589	15,9
6130	BEA-M-2SL	2							
5351	BEA-M-2H	2			2				22,0
6124	BEA-M-2HL	2							
5361	BEA-M-3S	3			1-3	2860	1313	1009	19,6
6131	BEA-M-3SL	3							
5355	BEA-M-3H	3			2-3				25,4
6125	BEA-M-3HL	3							
5363	BEA-M-4S	4			1-3,5	3790	1813	1439	22,2
6132	BEA-M-4SL	4							
5356	BEA-M-4H	4							28,2
6126	BEA-M-4HL	4							

Pressure drop diagram

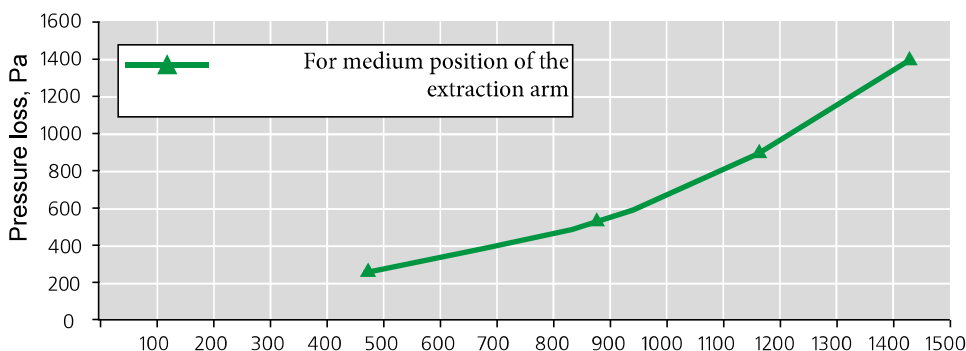

Accessories:

1. Support pole sPA (p. 24-25)
2. BEA bracket (p.15)
3. Remote control for BEA with lighting - PU (p.109)

Installation options



1. On the wall with support pole sPA-110, sPA-220
2. On the floor, on the support pole sPA-220
3. On the wall
4. On the mobile filtration unit ("S" version)

Type S

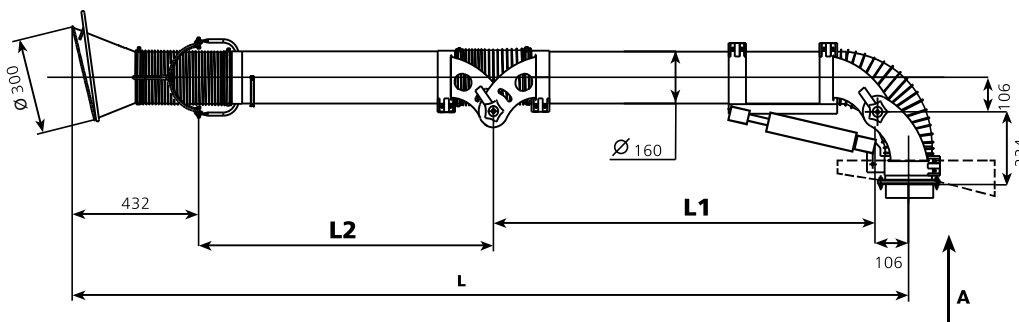

Optional lighting

Type H

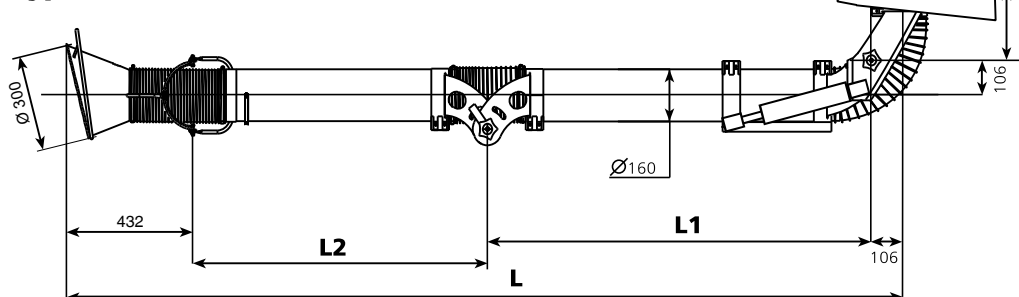

Bracket for "H" version

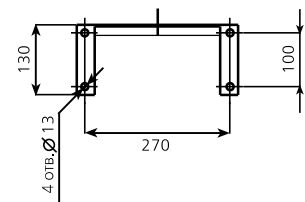

Note:
For "S" type of the arm, bracket must be ordered separately if needed.

Installation options / delivery set

Article #	Model	Installation options	Delivery set
5359	BEA-M-2S	Without bracket (standard): on mobile units like DCSC-S, ESP-M, DCA-M.	
6130	BEA-M-2SL	With bracket (optional): on the wall, column, support pole sPA	Set of lighting
5351	BEA-M-2H	With bracket (standard): on the wall, column, support pole sPA.	Bracket, connection kit
6124	BEA-M-2HL	Without bracket: directly to wall mounted filters: DCSC-W, ESP, DCA-W	Bracket, connection kit, set of lighting
5361	BEA-M-3S	Without bracket (standard): on mobile units like DCSC-S, ESP-M, DCA-M.	
6131	BEA-M-3SL	With bracket (optional): on the wall, column, support pole sPA	Set of lighting
5355	BEA-M-3H	With bracket (standard): on the wall, column, support pole sPA.	Bracket, connection kit
6125	BEA-M-3HL	Without bracket: directly to wall mounted filters: DCSC-W, ESP, DCA-W	Bracket, connection kit, set of lighting
5363	BEA-M-4S	Without bracket (standard): on mobile units like DCSC-S, ESP-M, DCA-M.	
6132	BEA-M-4SL	With bracket (optional): on the wall, column, support pole sPA	Set of lighting
5356	BEA-M-4H	With bracket (standard): on the wall, column, support pole sPA.	Bracket, connection kit
6126	BEA-M-4HL	Without bracket: directly to wall mounted filters: DCSC-W, ESP, DCA-W	Bracket, connection kit, set of lighting

BEA-200 | LIFTING-ROTARY EXTRACTION ARM



Description

Lifting-rotary extraction arm with increased capacity BEA-200 is intended for removal of various types of smoke, dust, gases, aerosols and other harmful substances from local source of allocation. Diameter of ducts and connection hoses of extraction arm - 200mm.

Intended use

- Welding, metal processing
- Food industry
- Precise machine building
- Ship building
- Car manufacturing
- Training classes

Features and advantages

- Increased diameter 200mm
- Hollow duct design
- Protective net in extraction nozzle
- Integrated damper
- Gaz shock absorbers
- Wide range of models
- Optional 450mm nozzle
- Rigid and durable design
- Set of working light (optional) for models with "L" index: halogen 20W lamp, two buttons on the nozzle to switch on light and fan, cable 4x0.5 L=10m (see pic. on page 15)
- Connection set: flexible hose Ø200mm, L=1,35m, hose clamp Ø200mm - 2pcs

Technical parameters, dimension (see. sketch on p.17)

Article	Model	Reach radius, m	Diameter, mm	Recommended airflow, cmh	Recommended installation height, m	L	L1	L2	L3	Weight, kg	
5311	BEA-200-2S	2	200	1200-2000	1-2	1984	713	597	438	19,1	
5906	BEA-200-2SL									19,5	
5909	BEA-200-2S-250					1934	713	602	382	20,0	
5314	BEA-200-2H					2	2027	714	597	438	27,9
5900	BEA-200-2HL										28,3
5903	BEA-200-2H-450						1976	714	602	382	28,8
5312	BEA-200-3S	3			3004						1313
5907	BEA-200-3SL					24,0					
5910	BEA-200-3S-450				2954	1313	1022	382	23,7		
5315	BEA-200-3H								2-3	3047	1314
5901	BEA-200-3HL				32,5						
5904	BEA-200-3H-450				2996	1314	1022	382		32,2	
5313	BEA-200-4S	4	3884	1813						1397	438
5908	BEA-200-4SL				27,7						
5911	BEA-200-4S-450		3834	1813	1402	382	27,3				
5316	BEA-200-4H						2-3,5	3927	1814	1397	438
5902	BEA-200-4HL		35,5								
5905	BEA-200-4H-450		3876	1814	1402	382		35,0			

Installation options (shown on p.15)

Aerodynamic characteristics

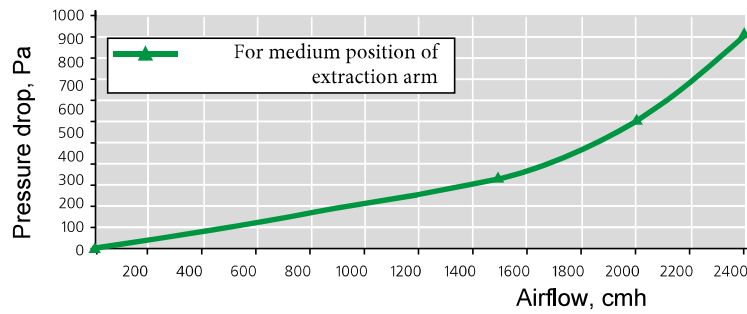

- Accessories:**
1. Support pole sPA
 2. Bracket for BEA-200
 3. PU remote for BEA with lighting (p.109)
 4. Components of automatics (see "Automatic control systems", p.106)

Dimensions of BEA-200 (type S)

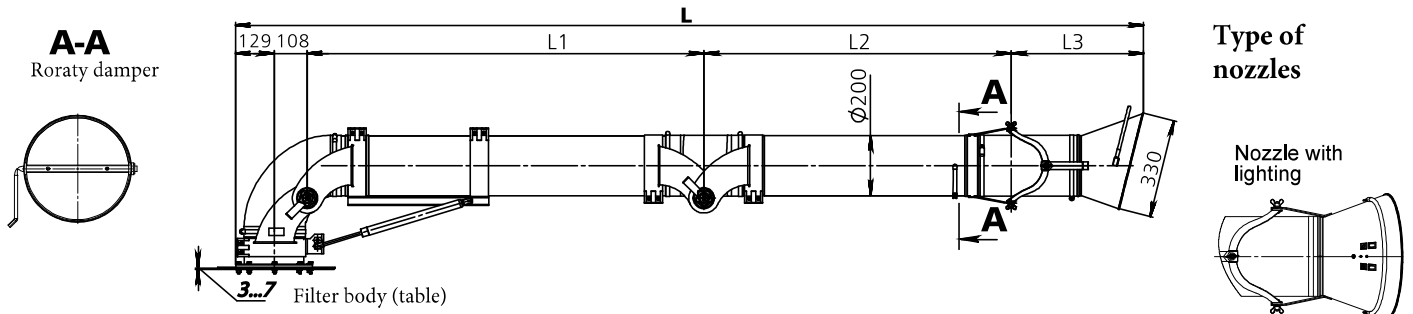

Dimensions of BEA-200 (type H)

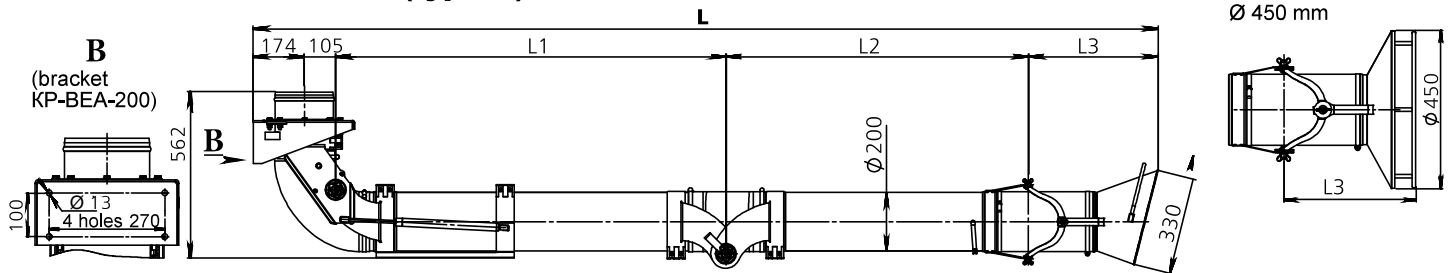

Installation options / delivery set

Article #	Model	Delivery set	Installation options
5314	BEA-200-2H	Conical nozzle 330mm, bracket, connecting set.	With bracket (standard): on the wall, column, support pole sPA.
5315	BEA-200-3H		
5316	BEA-200-4H		
5900	BEA-200-2HL	Conical nozzle 330mm, lighting, bracket, connecting set.	Without bracket (bracket is detached): on the wall mounted filters DCSC-W200, ESP-5000.
5901	BEA-200-3HL		
5902	BEA-200-4HL		
5903	BEA-200-2H-450	Large nozzle 450mm, lighting, bracket, connecting set.	
5904	BEA-200-3H-450		
5905	BEA-200-4H-450		
5311	BEA-200-2S	Conical nozzle 330mm. Bracket for wall mounting is to be ordered separately (art. code 6297).	Withouth bracket (standard): on mobile filters DCSC-Mx-200.
5312	BEA-200-3S		
5313	BEA-200-4S		
5906	BEA-200-2SL	Conical nozzle 330mm. Lighting. Bracket for wall mounting is to be ordered separately (art. code 6297).	With bracket (optional, ordered separately): on the wall, column, support pole sPA.
5907	BEA-200-3SL		
5908	BEA-200-4SL		
5909	BEA-200-2S-450	Large nozzle 450mm. Bracket for wall mounting is to be ordered separately (art. code 6297).	
5910	BEA-200-3S-450		
5911	BEA-200-4S-450		
6297	KP-BEA-200	Bracket for BEA-200 with flange, w/o fasteners	Fixing of BEA with "S" index on the wall, column, support pole sPA.

EF-M

LIFTING-ROTARY EXTRACTION ARM



Description

Lifting-rotary extraction arm on console, for removal of welding fumes, oil mist, dust and other pollutants directly from point of its allocation. Rotary console significantly increases reach radius and extraction arm allows capturing fumes from points located up to 2m higher than mounting point.

Intended use

- Welding, metal processing
- Precise machine building
- Ship building
- Car manufacturing

Features and advantages

- Hollow design on ducts
- Durable support due to rotary console
- Large variety of sizes
- Integrated damper
- Rigid and durable design
- Lighting set with two buttons on the nozzle to switch on the lamp and fan (optional).

Technical characteristics

Article	Model	Length, m	Ø Diameter, mm	Recommended airflow, cmh	Installation height, m
5365	EF-M-1520	3	160	1000-1200	2
5366	EF-M-1520-L	3			2
5367	EF-M-1530	4			2-3
5368	EF-M-1530-L	4			2-3
5369	EF-M-2520	4			2
5370	EF-M-2520-L	4			2
5371	EF-M-2530	5			2-3
5372	EF-M-2530-L	5			2-3
5373	EF-M-3520	5			2
5374	EF-M-3520-L	5			2
5375	EF-M-3520	6			2-3
5376	EF-M-3520-L	6			2-3
5377	EF-M-4520	6			2
5378	EF-M-4520-L	6			2
5379	EF-M-4530	7			2-3
5380	EF-M-4530-L	7			2-3
5080	EF-M-4540	8			2-3

Aerodynamic characteristics

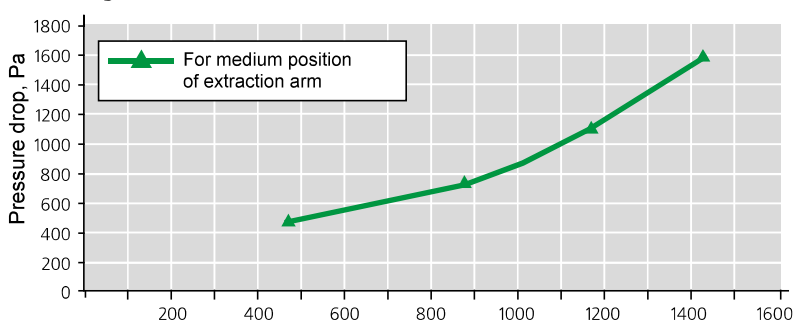

Accessories:

1. Universal mounting column sKMU
2. Fan
3. Filter
4. Induction sensor IWS
5. PU remote for BEA with lighting
6. Automatic damper AD with controller ICE-LC
7. Signal coordinating unit USS
8. Frequency inverter

Dimensions

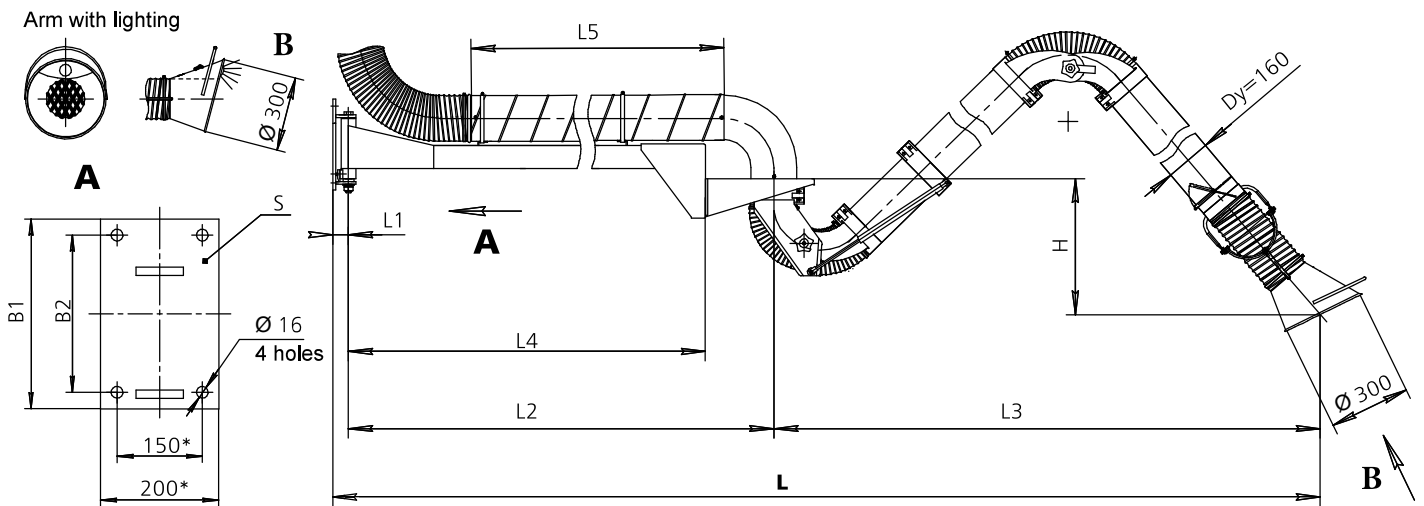

Major dimensions and weight of extraction arms EF-M

Model	L, max	L 1	L 2	L 3, max	L 4	L 5	S	B 1	B 2	H, max	Weight, kg						
FM-M-1520	3650	51	1815	1780	1550	900	6	320	270	1875	54						
FM-M-1520 L				1550							55						
FM-M-1530	4670		2800	1780	2550	1900				10	420	370	2895	57			
FM-M-1530 L														2800	58		
FM-M-2520	4650		2815	1780	2550	1900							10	420	370	1875	65
FM-M-2520 L																	2550
FM-M-2530	5670	2800	1780	4560	3900	10	420	370	2895							69	
FM-M-2530 L																2800	70
FM-M-3520	5660	3825	1780	3560	2900				10	420	370	1875				88	
FM-M-3520 L																3560	89
FM-M-3530	6680	2800	1780	4560	3900							10	420	370	2895	92	
FM-M-3530 L																2800	93
FM-M-4520	6660	4825	1780	4560	3900	10	420	370							1875	102	
FM-M-4520 L																4560	103
FM-M-4530	7680	2800	1780	4560	3900				10	420	370				2895	107	
FM-M-4530 L																2800	108

Delivery set / mounting options

Model	Length of console, m	Delivery set
FM-M-1520	1,5	Extraction arm, connecting set (hose Ø160mm, L=1350mm, hose clamps Ø160mm - 2pcs).
FM-M-1530	1,5	
FM-M-2520	2,5	
FM-M-2530	2,5	
FM-M-3520	3,5	
FM-M-3530	3,5	
FM-M-4520	4,5	
FM-M-4530	4,5	
FM-M-4540	4,5	
FM-M-1520-L	1,5	
FM-M-1530-L	1,5	
FM-M-2520-L	2,5	
FM-M-2530-L	2,5	
FM-M-3520-L	3,5	
FM-M-3530-L	3,5	
FM-M-4520-L	4,5	
FM-M-4530-L	4,5	

Reach radius, m

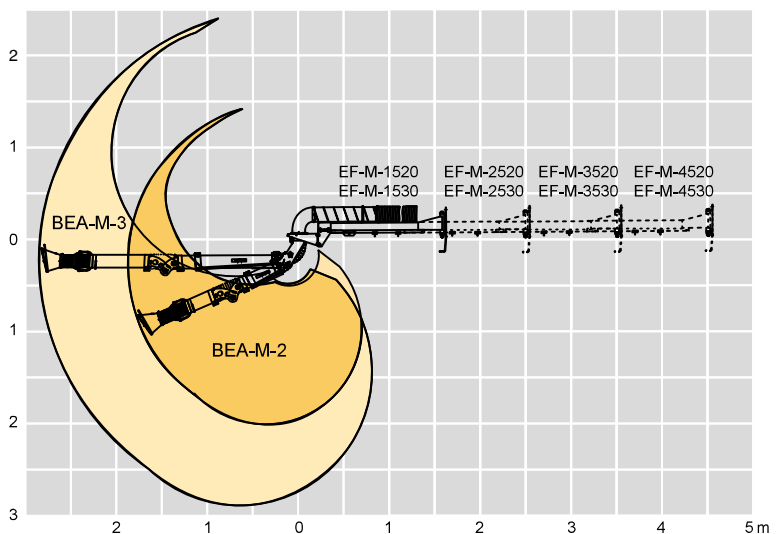

EF-200

LIFTING-ROTARY EXTRACTION ARM



Description

Lifting-rotary extraction arm of increased capacity, on console, for removal of welding fumes, oil mist, dust and other pollutants directly from point of its allocation. Rotary console significantly increases reach radius and extraction arm allows capturing fumes from points located up to 2m higher than mounting point.

Intended use

- Welding, metal processing
- Precise machine building
- Ship building
- Car building

Features and advantages

- Hollow duct design
- Durable support due to rotary console
- Large variety of sizes
- Integrated air damper
- Rigid and durable design
- Increased capacity

Technical characteristics

Article	Model	Length, m	Ø Diameter, mm	Recommended airflow, cmh	Installation height, m	Length of the console, m	Delivery set
5627	EF-200-1520	3	200	1000-2000	2	1,5	Extraction arm, connection set (hose Ø 160mm, L=1350mm and 2 hose clamps)
5628	EF-200-1530	4			2-3	1,5	
5629	EF-200-2520	4			2	2,5	
5630	EF-200-2530	5			2-3	2,5	
5631	EF-200-3520	5			2	3,5	
5632	EF-200-3530	6			2-3	3,5	
5633	EF-200-4520	6			2	4,5	
5634	EF-200-4530	7			2-3	4,5	

Aerodynamic characteristics

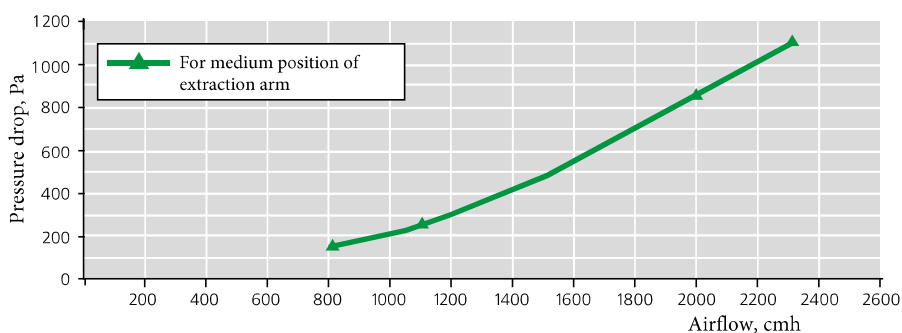

Dimensions

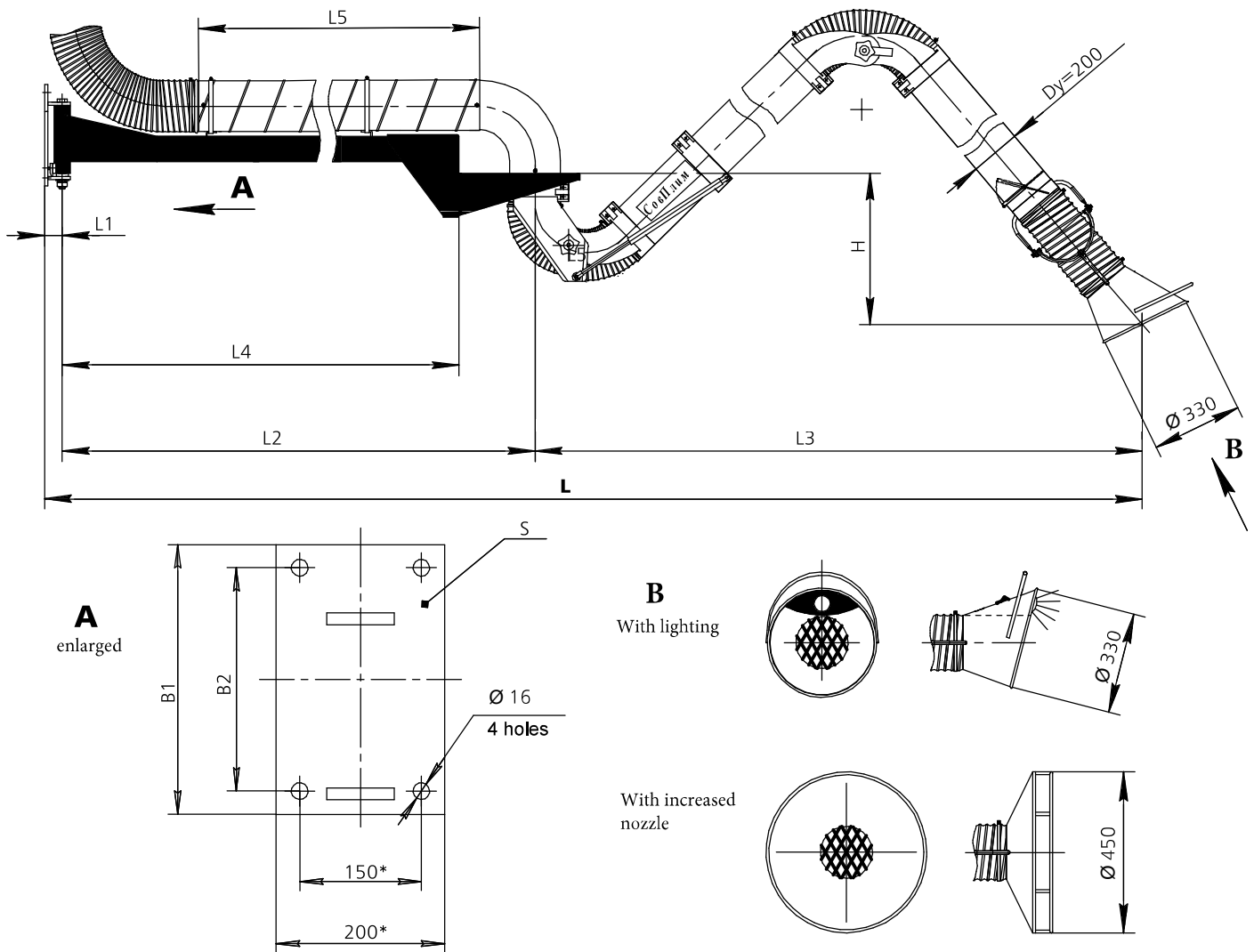

Major dimension and weight of extraction arms EF-200

Model	L max	L 1	L 2	L 3 max	L 4	L 5	S	B 1	B 2	H max	Weight, kg
EF-200- 1520	3600	51	1725	1820	1550	900	6	320	270	2025	62
EF-200-1520 L											63
EF-200- 1520- 450											63
EF-200- 1530	4620	51	2840	1820	2550	1900	6	320	270	3045	70
EF-200-1530 L											71
EF-200- 1530- 450											71
EF-200- 2520	4600	51	2725	1820	2550	1900	6	320	270	2025	74
EF-200-2520 L											75
EF-200- 2520- 450											75
EF-200- 2530	5620	51	2840	1820	4560	3900	10	420	370	3045	82
EF-200-2530 L											83
EF-200- 2530- 450											83
EF-200- 3520	5610	56	3735	1820	3560	2900	10	420	370	2020	98
EF-200-3520 L											99
EF-200- 3520- 450											99
EF-200- 3530	6630	56	4735	2840	4560	3900	10	420	370	3040	106
EF-200-3530 L											107
EF-200- 3530- 450											107
EF-200- 4520	6610	56	4735	1820	4560	3900	10	420	370	2020	112
EF-200-4520 L											113
EF-200- 4520- 450											113
EF-200- 4530	7630	56	4735	2840	4560	3900	10	420	370	3040	120
EF-200-4530 L											121
EF-200- 4530- 450											121

EC | TELESCOPIC EXTRACTION ARM ON CONSOLE



Description

EC is a telescopic extraction arm with vertical height changing, fixed on the folding console. It is intended for removal of welding aerosols and similar types of fumes and smokes. Console allows increasing of the reach radius when work places have large area.

Intended use

- Welding, metal processing
- Precise machine building
- Ship building
- Automotive industry

Features and advantages

- Increased reach radius - up to 8m
- Detachable air intake nozzle for connection of additional hose (up to 10m)
- Telescopic extraction arm
- Integrated damper next to air intake nozzle
- Rigid and durable design
- Folding rotary console

Technical characteristics

Article	Model	Length, m	Ø Diameter, mm	Recommended airflow, cmh	Installation height, m	Console length, m	Delivery set
5137	UK-3016	3	160	800-1200	2-3	1,5 + 1,2	Preassembled extraction arm, connecting set (hose Ø160mm, L=1300mm and 2 hose clamps)
5138	UK-4516	4,5				2,5 + 1,7	
5139	UK-6016	6				3,5 + 2,4	
5140	UK-8016	8				4,5 + 3,4	

Pressure loss diagram

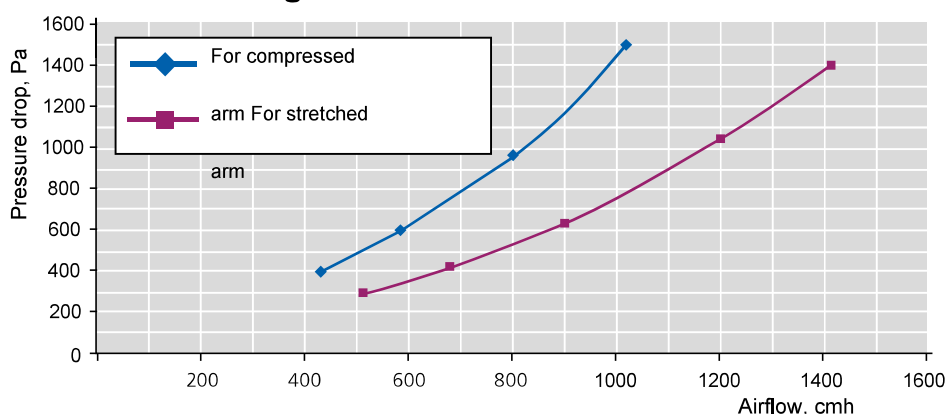

Accessories:

1. Mounting column sKMU-300 or sKMU-300R
2. Fan
3. Air cleaning filter
4. Flexible extraction hose SLE with fast connecting joining MV-160
5. Automatics components (see p."Automatic control systems", p.106)

Dimensions

Mounting plate

EC-3016/4516

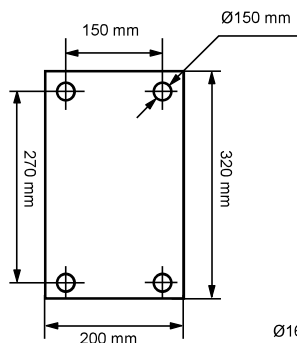

EC-6016/8016

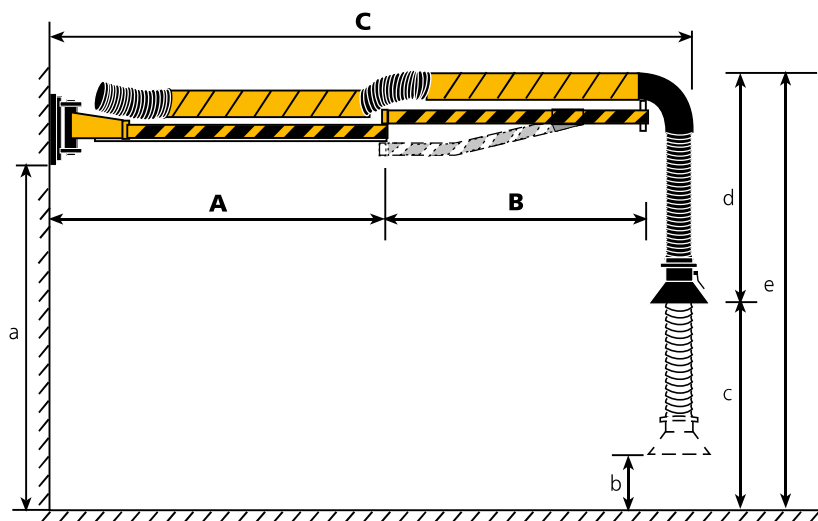
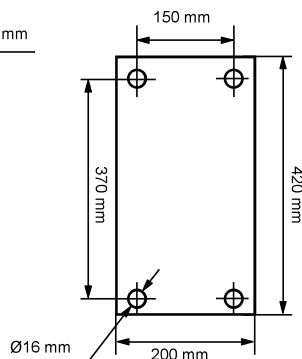

Model	A, mm	B, mm	C, mm	a, mm	b, mm	c, mm	d, mm	e, mm	Duct part diameter, mm	Extraction nozzle diameter, mm
EC-3016	1550	1200	3000	3250	550	2100	1400	3500	160	300
EC-4516	2550	1750	4550	3250	550	2100	1400	3500		
EC-6016	3550	2400	6200	3250	550	2100	1400	3500		
EC-8016	4550	3400	8200	3250	550	2100	1400	3500		

Reach radius

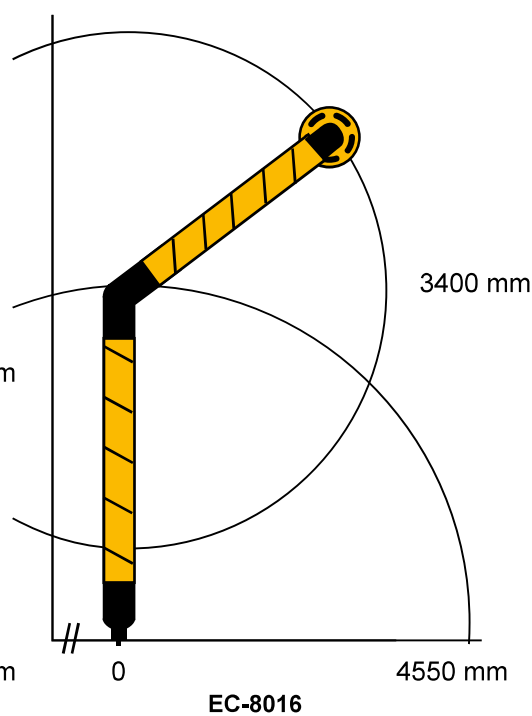
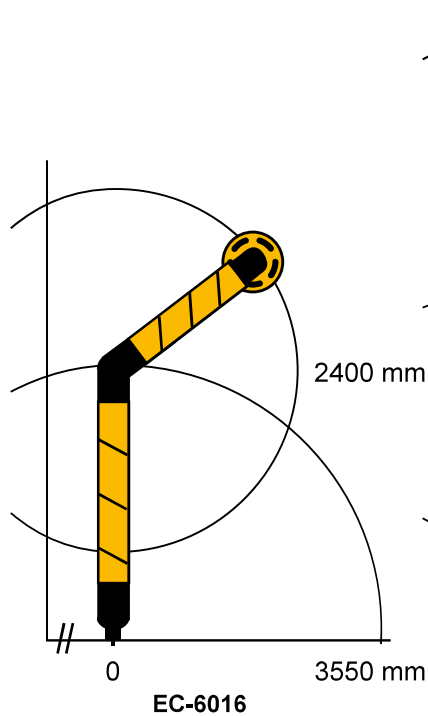
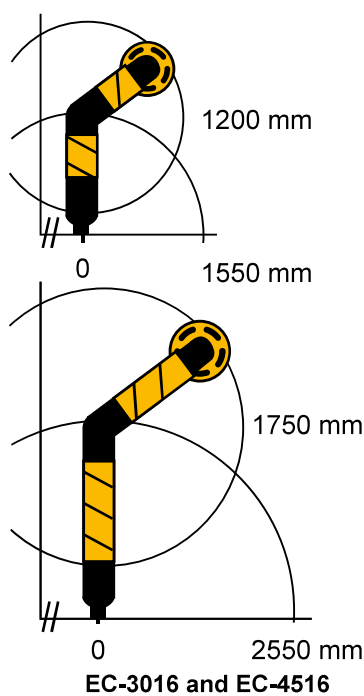

SUPPORT POLES sPA and sKMU columns

MOUNTING OF
EXTRACTION ARMS



Description

Support poles sPA and mounting columns sKMU are used when walls and columns of the building are located far away from work places and mounting extraction arms on those is impossible or complicated.

sPA and sKMU are the columns of necessary length and capable of carrying various load. Top part of columns is fitted with the plate for installation of extraction arms of various types, models and reach radius. Both have the support plate for mounting on the floor, wall and ceiling (not for sKMU) or any other prepared basis with anchor or regular bolts.

Intended use

Support poles sPA have lighter design and usually are being used for installation of extraction arms like LamArm-125, BEA-M and BEA-200 with reach radius less than 4m. Depending on the type of extraction arm, support poles may be mounted on the floor, wall or ceiling. They also may be used for mounting of other equipment, for example, oil mist filters MM.

Mounting columns sKMU and sKMU-R are being used for installation of extraction arms like EF-M, BEA-300 and EC, which are heavier and having the reach radius up to 8 meters.

Technical characteristics of support poles sPA

Code	Model	Name	Length, L, mm	Corresponding types of extraction arms
6059	sPA-110	Support pole for extraction arm	1100	LabArm-125, BEA-M, BEA-200
6060	sPA-220		2200	

Technical characteristics of universal mounting column sKMU

Code	Model	Name	Length, mm	Corresponding types of extraction arms		
				EF-M	EF-200	EC
6059	sKMU-300	Univeral mounting column	3010	EF-M-1520 (L)	EF-200-1520 (L) EF-200-1530 (L) EF-200-2520 (L) EF-200-2530 (L)	EC-3016 EC-4516
				EF-M-1530 (L)		
				EF-M-2520 (L)		
				EF-M-2530 (L)		
6060	sKMU-300-R	Reinforced universal mounting column	3010	EF-M-3520 (L)	EF-200-3520 (L) EF-200-3530 (L) EF-200-4520 (L) EF-200-4530 (L)	EC-6016 EC-8016
				EF-M-3530 (L)		
				EF-M-4520 (L)		
				EF-M-4530 (L)		
				EF-M-4540 (L)		

Dimensions for mounting column sKMU

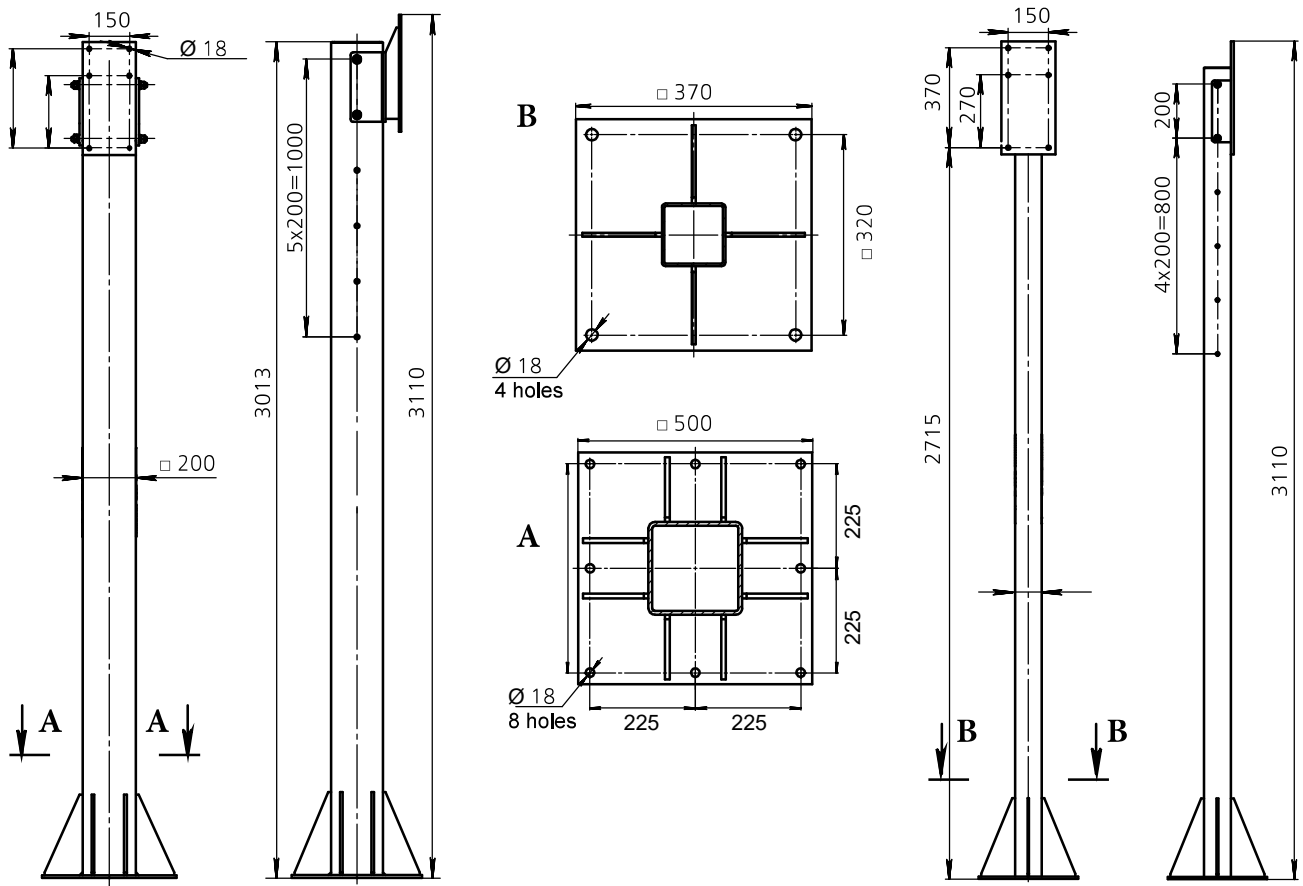

Dimensions of support pole sPA

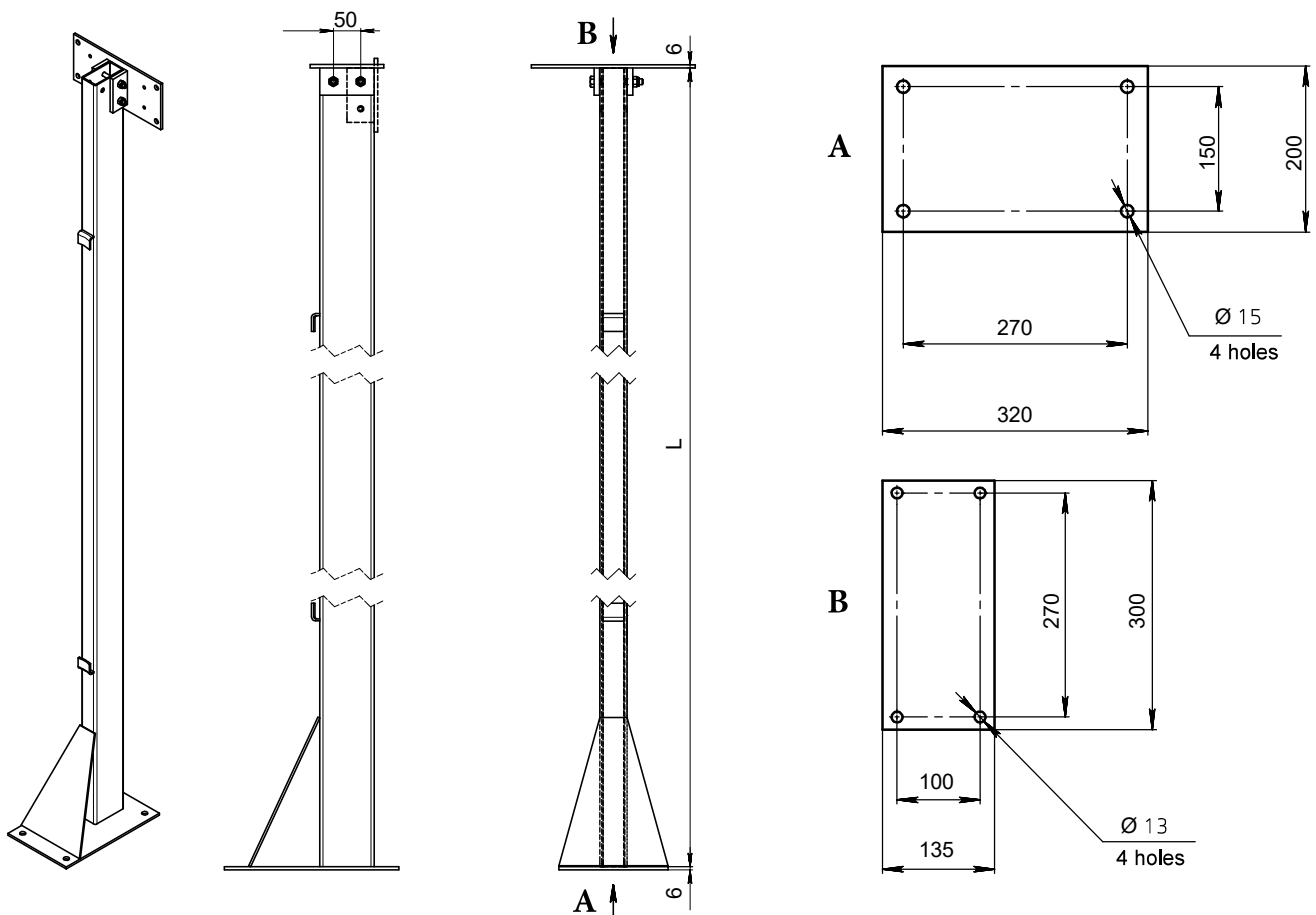

3 DUST COLLECTORS, CYCLONES, SEPARATORS



page 27

CPO

Direct flow cyclone with supports for capturing of coarse and medium size dust particles. Available capacities 1000, 2500 and 4000 cmh. Designed for installation in straight duct segment.



page 29

BCPO

Block of direct flow cyclones with supports for capturing of coarse and medium size dust particles. Air flow capacity 10.000 cmh. Designed for installation in straight duct segment.



page 31

SVP-5000

Stationary extraction panel for capturing of dust at grinding work places for large scale products. Requires connection to centralized filter and/or extraction fan.



page 32

PU

Stationary dust collector for sharpening, grinding, polishing and similar machines. High cleaning efficiency due to two stage cleaning system: cyclone inlet and sleeve filter bags. Equipped with manual sleeve shaking system.

CPO | DIRECT FLOW CYCLONE



Description

CPO direct flow cyclones with supports (complete set) are the centrifugal dust collectors for dry, non-sticky medium and coarse dust. CPO cyclones are intended for installation into any straight horizontal duct segments of any ventilation system. Cyclones are equipped with 40 liters dust bin, connected with flexible hose, allowing installation of cyclone at any height while dust bin is standing on the floor or any support just by using longer connection duct or hose. In order to provide high particle capturing efficiency, air flow speed inside direct flow cyclone should be not less than 12 m/s.

Intended use

- As a stand alone dust collector
- As a first stage of filtration before fine filters for lowering the dust concentration in air flow
- As spark arrestor to reduce risk of fire do to sparks hitting the ventilation system

Limitations

- Not used for sticky and fiber dust, as well as dust tended to decay and spontaneous ignition.
- Cleaned air flow should not contain aggressive and explosive substances and gases.
- Maximum temperature of airflow 110°C.



Features and advantages

- Up to 2 times more efficient comparing to classic cyclones.
- Doesn't require additional space for installation on the wall.
- Very compact.
- External dust bin.
- Simple installation.
- Decreases risk of sparks hitting the ventilation system.

Technical characteristics

Article	Model	Recommended airflow, cmh	Duct diameter, mm	Filtration efficiency for medium quartz dust, %	Filtration efficiency for coarse quartz dust, %	Weight kg
5500	CPO-1000	1000	160	80-88	92	6,7
5556	CPO-2500	2500	250			15,7
5626	CPO-4000	4000	315			25,5

Description of CPO's components

Sketch	Model	Description
	CB-1000 CB-2500 CB-4000	Cyclone body with corresponding diameter (160/250/315) with two nipples. Wall thickness 1,5mm (available option - reinforced body, made of 3mm steel).
	CS-1000 CS-2500 CS-4000	Set of supports for cyclone of corresponding diameter (160/250/315 mm).
	DB-40-160 DB-40-250 DB-40-250	Dust bin 40 liters, hose Ø160mm, L=300 mm; hose clamp Ø160 – 2pcs. Dust bin 40 liters, hose Ø250mm, L=300 mm; hose clamp Ø250 – 2pcs. Dust bin 40 liters, hose Ø250mm, L=300 mm; hose clamp Ø250 – 2pcs.

Dimensions and connections of CPO

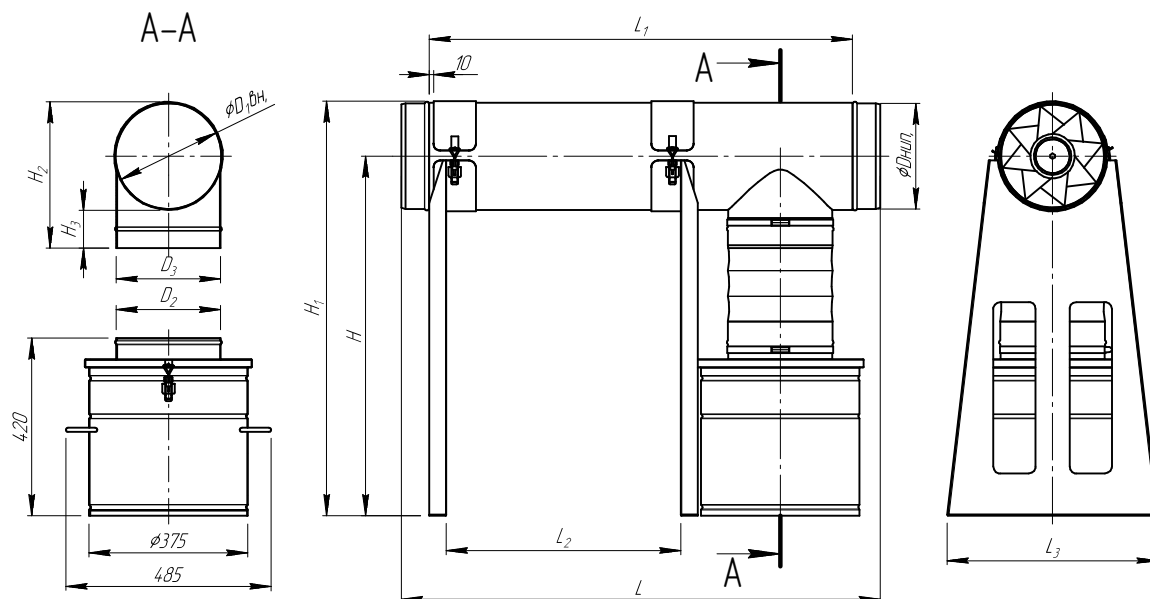

Model	Size, mm										
	L	L1	L2	L3	H	H1	H2	H3	Ø Dnip	Ø D ₁ inner	Ø D ₂ , D ₃
CPO-1000	757	655	265	420	850	930	244	80	160	161	156
CPO-2500	1132	1000	555	500	850	980	334	80	250	251	246
CPO-4000	1615	1500	1025	500	850	1012	399	80	314	316	246

Delivery scope for CPO

Article	Model	Delivery set
5500	CPO-1000	CB-1000, CS-1000, DB-40-160
5556	CPO-2500	CB-2500, CS-2500, DB-40-250
5626	CPO-4000	CB-4000, CS-4000, DB-40-250

Aerodynamic characteristic

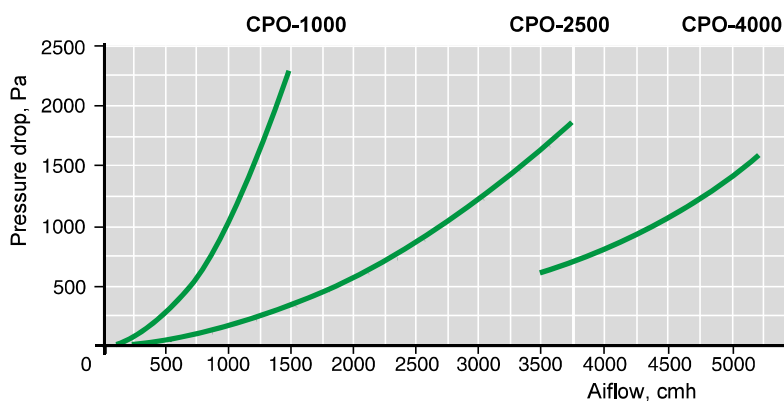

BCPO | BLOCK OF CYCLONES



Description

Block of direct flow cyclones with supports BCPO (full set) is an inertial centrifugal dust collector, intended for capturing of dry not sticky medium and coarse dust.

BCPO is a block of 4 bodies of CB-2500, placed in a single casing with common socket for standard dust bin. Block of cyclones is being installed most commonly on the floor with a set of supports.

For highly abrasive types of dust, reinforced body can be manufactured out of 3mm steel.

BCPO is intended for installation in straight horizontal duct segments of various ventilation systems. Delivery set includes standard 60 liters dust bin DB-60-250. Conical transition pieces are to be ordered separately, depending on the connected duct diameter.

For maximum capturing efficiency, airflow speed inside of the cyclone should be around 12 m/s.

Intended use

- As a stand alone dust collector.
- As a first stage of filtration before fine filters for decreasing of initial concentration of dust.
- For decreasing the risk of getting sparks into the ventilation.

Limitations

- Not used for sticky and fiber dust, as well as dust tended to decay and spontaneous ignition.
- Cleaned air flow should not contain aggressive and explosive substances and gases.
- Maximum temperature of airflow 110°C.

Features and advantages

- Up to 2 times more efficient comparing to classic cyclones.
- Compact body.
- Convenient dust bin.
- Simple installation.
- Decreases risk of getting sparks into the ventilation system.

Technical characteristics

Parameter	Value
Nominal airflow, cmh	10 000
Cleaning efficiency for medium size dust, %	85 - 89
Cleaning efficiency for coarse dust, %	95 - 99
Dust bin capacity, liters	60
Weight without supports and transition pieces, kg	110
Dimensions L x W x H, mm	1050x828x1213
Transition pieces (optional) diameter, mm	800x400, 800x500, 800x630

Dimensions and connections for BCPO

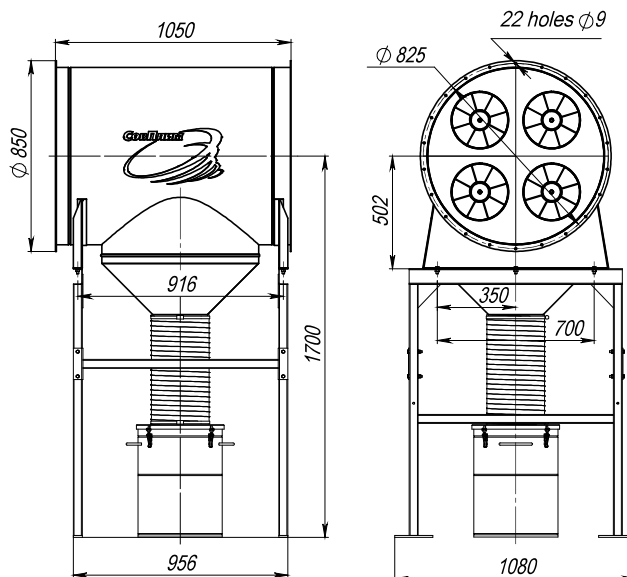

(block of cyclones is shown with optional transition pieces CT)

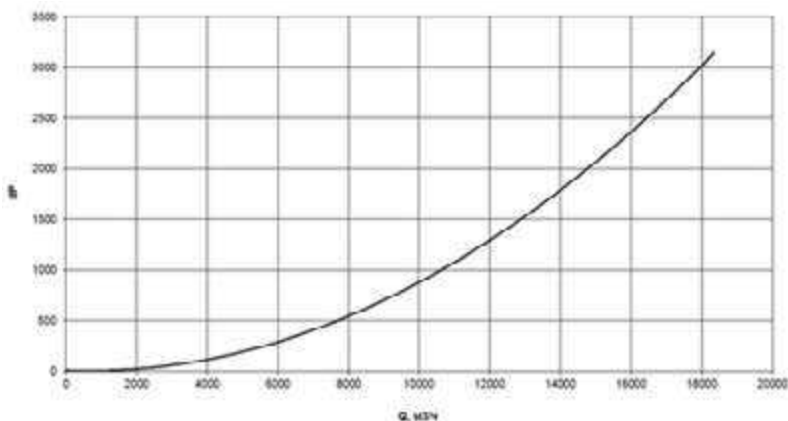

Aerodynamic characteristic



Production range, delivery set, options

Drawing	Article	Model	Description
	5644	BCPO-4x2500	Block of cyclones with supports (full set). Delivery set includes: block of cyclones BCP-4x2500, support BCS-2500x4, dust bin DB-60-250, connection hose for dust bin Ø250mm, L=1m with hose clamps and sealing. Attention! 2 pcs of conical transition pieces must be ordered separately!
Options			
	6446	CT 800x400	Conical transition piece for BCP (for Ø400mm duct)
	6447	CT 800x500	Conical transition piece for BCP (for Ø500mm duct)
	6448	CT 800x630	Conical transition piece for BCP (for Ø630mm duct)

SVP- 5000

STATIONARY EXTRACTION PANEL



Description

Stationary extraction panel SVP-5000 is intended for capturing and separating of dry coarse and medium size dust. Panel efficiently captures dust from the distance of up to 1.5m.

During work, operator should be positioned in front of the panel, facing towards it. Extraction panel SVP should be connected to filtration system from JSC "SovPlym" with corresponding productivity. Type of the installation is being chosen with consideration of process intensity and dust properties.

Intended use

- Buffing and polishing of welding seams.
- Removal of rust and burrs.
- Processing of large scale items.

Limitations

- Not supposed to be used for explosive and aggressive substances.
- Not supposed to be used for materials inclined to decay and spontaneous ignition.

Features and advantages

- Special shape of the panel provides efficient dust capturing at the distance up to 1.5m.
- Optimal airflow.
- Efficient separation of coarse particles.
- Simple installation without extra supports.

Technical characteristics

Parameter	Value
Diameter of connected duct, mm	315
Dimensions of suction grid, mm	350 x 1200
Dimensions of the inlet screen, mm	1450 x 2000
Distance from panel center to the floor, mm	1000
Effective face surface area of the extraction panel, m ²	0,154
Recommended airflow, cmh	5000
Speed of air passing through the inlet grid, cmh	9
Dust bin capacity, liters	20
Overall dimensions WxLxH, mm	640 x 2000 x 1800
Weight, kg	132

Dimensions and connections

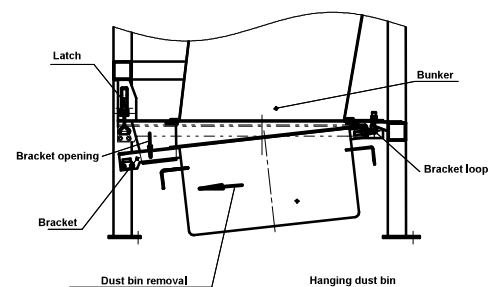
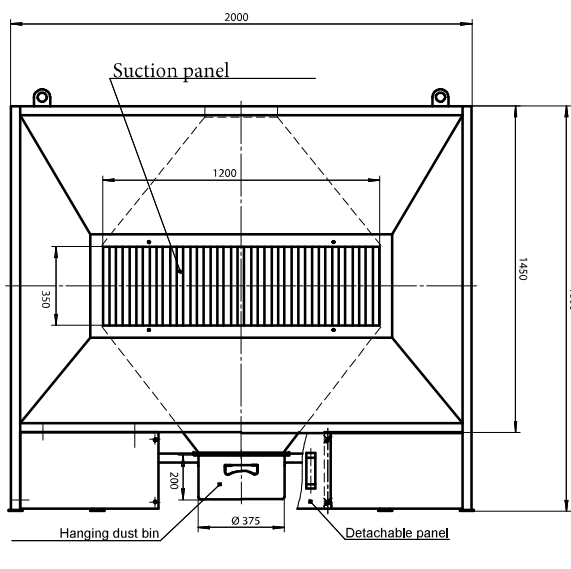

PU | DUST COLLECTOR



Description

Dust collectors are stationary units, intended for air cleaning from dry non sticky medium and coarse dust in workshops of various industrial factories, training classes, mechanical repair shops. Filtration efficiency for 5 micron particles is not less than 92%.

Intended use

- Aerospace engines and turbines manufacturing.
- Construction materials manufacturing.
- Machine building and metal processing.
- Car manufacturing.
- Repair workshops.
- Training classes.

Limitations

Environment and cleaned airflow should be not explosive and not containing aggressive vapors and gases.

Features and advantages

- Two-stage filtration system.
- Manual shaking of filtration sleeves.
- Detachable door for fast sleeve replacement.
- Suitable for various capacity fans.

Technical parameters

Article	Model	Max. airflow, cmh	Recommended fan	Max. pressure drop, Pa	Filtration surface area, m ²	Ø of inlet/outlet	Filtration efficiency, %	Mass, kg
5696	PU-400	400	VMA-1100	1000	2,2 (16 shortened sleeves)	100/160	≤ 92 (for particles ≥ 5 micron)	42
5697	PU-600	600	VMA-1100 VMA-1800	1000	2,2 (16 shortened sleeves)	125/160		42
5511	PU-800	800	VMA-1800 VMA-2100	1000	4,2 (16 sleeves)	160/160		50
5512	PU-1500	1500	VMA-3000	1100	5 (19 sleeves)	160/250		70
5513	PU-2500	2500	VMA-3000 VMA-4700	1100	8,2 (31 sleeves)	250/250		90
5514	PU-4000	4000	VMA-4700 VMA-6000	1200	9,8 (37 sleeves)	280/250		100

Dimensions and connections

Article	Model	H, mm	h, mm	D, mm	d, mm	d1, mm	L, mm
5696	PU-400	1270	480	573	100	160	450
5697	PU-600	1270	480	573	125	160	450
5511	PU-800	1640	480	573	160	160	450
5512	PU-1500	1700	500	650	160	250	520
5513	PU-2500	1700	500	810	250	250	630
5514	PU-4000	1810	560	890	280	250	750

Dimensions and connections

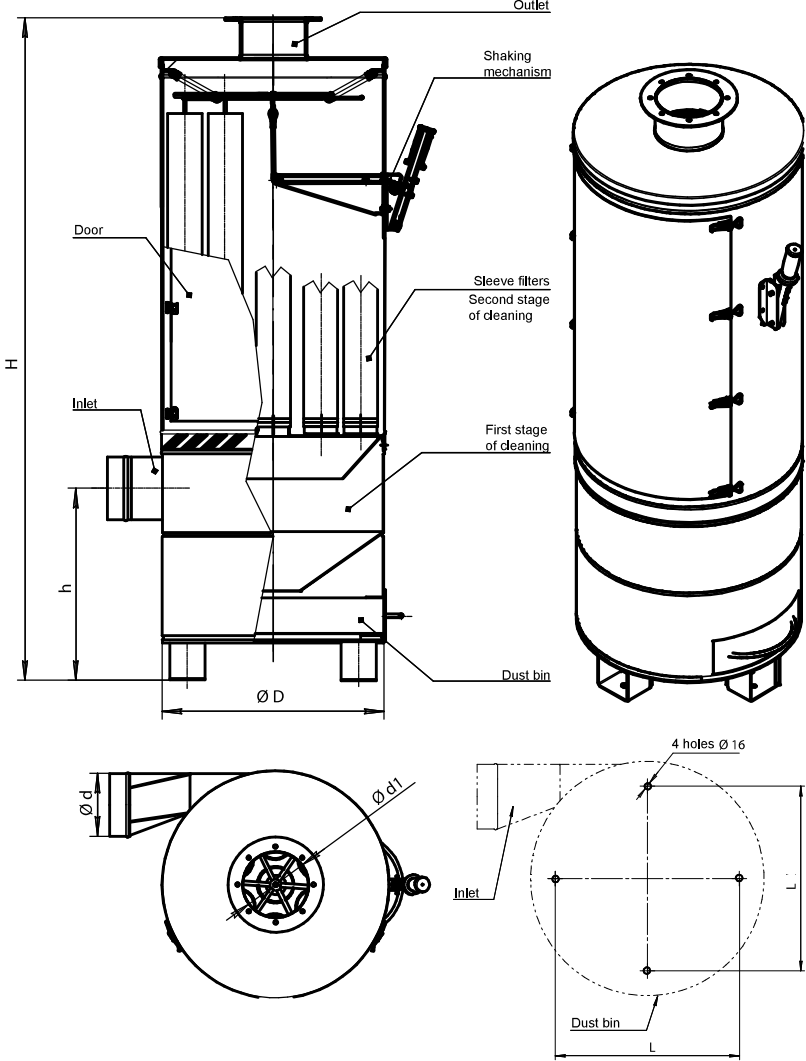

4. Filtration principles

Types of air filters

1. MECHANICAL FILTERS



This type of filters provide air filtration due to capturing the dust particles on the surface of accumulative, replaceable filtration element, which is not supposed to be re-used. Final choice of material depends on dust properties and required filtration class. Filtration elements are made in a form of cartridges (cassettes) with pleated material for increasing the dust capacity. After saturation, cartridges must be replaced by new ones. Mechanical accumulative filters are used for air filtration with low dust concentration.

Advantages: simple design and low cost of units. Easy maintenance.

Disadvantages: filtration elements can't be regenerated. When reaching maximum dust capacity are to be replaced.

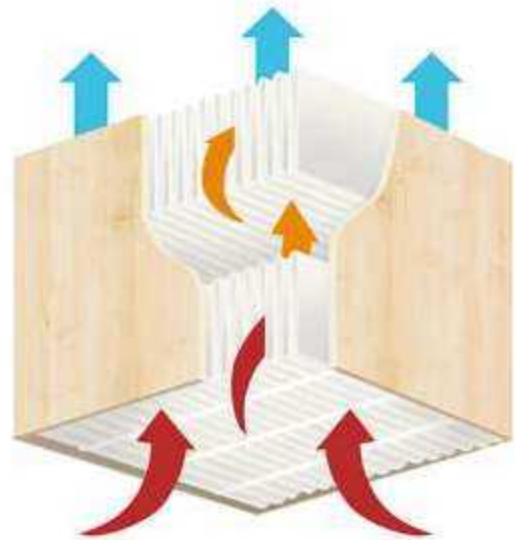

2. SELF-CLEANING MECHANICAL FILTERS



These filters use the same principle as accumulative mechanical filters, but, they are equipped with automatic cartridge cleaning system. Cleaning is done by purges of compressed air, supplied inside of filtration element. Special air splitting insert evenly distributes pulse energy along whole inner surface of filtration element, providing efficient pushing of the accumulated dust off the outer surface. Implementation of air splitting insert allows decreasing consumption of compressed air by 50%. Self-cleaning filters use various types of filtration elements: pleated cartridges (flat or round), flat bags on the metal frame (round or flat).

Advantages: long life time of filtration elements. Suitable for heavy load, intense working regimes and high dust concentrations.

Disadvantages: require compressed air connection, noise from the work of self-cleaning system.

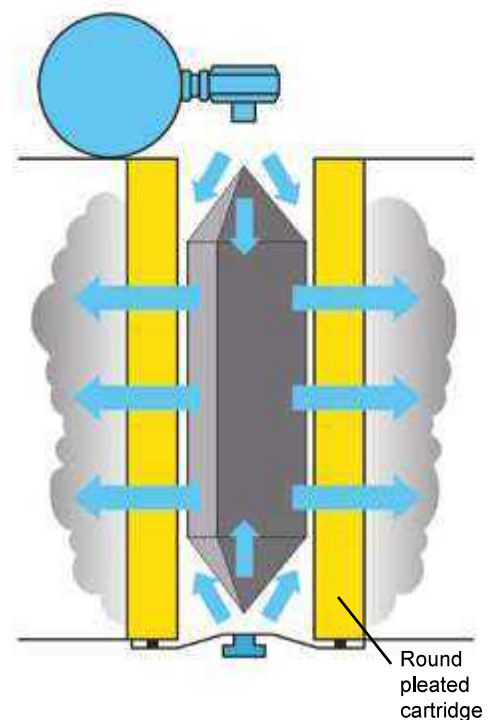

3. ELECTROSTATIC FILTERS



Electrostatic filtration – very efficient method for capturing of fine dust, such as welding aerosols, tobacco smoke and, even, bacteria. This method allows capturing of particles with size from 100 microns (thickness of human hair) down to 0,005 microns (size of a virus). Larger particles are being captured with mechanical pre-filter. Dust particles, flying inside the filter, get charged in electrostatic field of ionization cell, being under 12000 V voltage. Then they pass through precipitation cell, which is under 6000 V voltage. In this cell, under the influence of electrostatic field, particles settle on negatively charged plates. Additionally, optional activated carbon cartridge can be installed in order to capture gaseous components and smells.

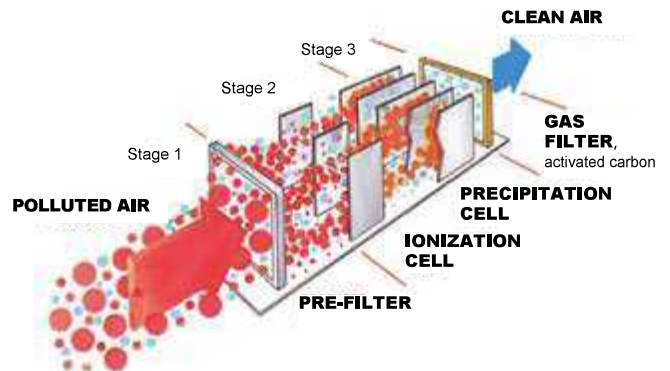
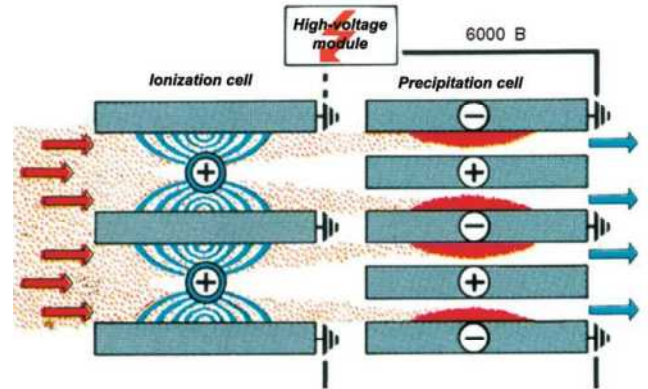

Advantages: filtration elements do not require replacement, capture finest particles of dust and bacteria, are suitable for filtration of oily smoke and fumes.

Disadvantages: ionization and precipitation cells require regular washing. Electrostatic filters aren't suitable for metal dust filtration and high concentrations of dust.

4. GAS FILTERS

4.1. Ion-exchange filters



Ion-exchange filters clean air by binding toxic substances by active groups of special ion-exchange material. Such filters capture toxic substances of acidic nature and other compounds, such as: HS, formaldehyde, phenols, ethers, alcohols, water soluble salts etc.



4.2. Activated carbon filters



Activated carbon filters neutralize smells, ozone and some other toxic substances and gases. They work on adsorption principle: activated carbon adsorbs molecules of dangerous and harmful substances.

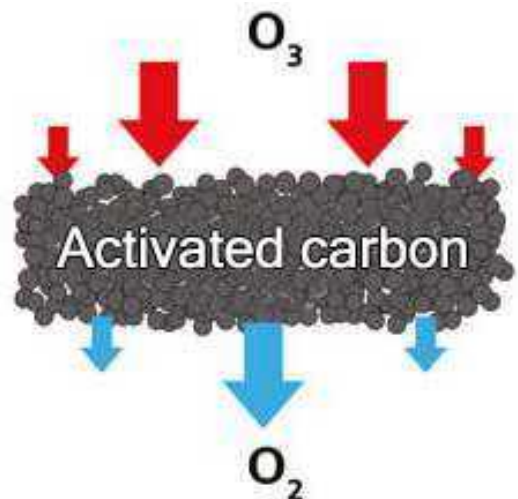

Advantages: rather low cost and simple maintenance. Majority of models have an option of regeneration of ion-exchange material, providing long life of filtration material before replacement. High cleaning efficiency for majority of toxic pollutants.

Disadvantages: frequent replacement of filtration elements. Preliminary cleaning of gas flow from dust is required.

Major types of replaceable filtration elements

1. PLEATED FILTRATION CARTRIDGES (ROUND, CONICAL)

Round pleated cartridges are used for cleaning of air with initial dust concentration below 2g/m^3 . They have large filtration surface area and small dimensions, making them ideal for compact filters and mobile units. Conical pleated cartridges have same advantages as round ones and are specially designed for high-vacuum equipment from SovPlym. Their shape provide better cyclone effect at the stage of preliminary filtration, making service life of the filter significantly longer.



2. FLAT PLEATED FILTRATION CARTRIDGES

Flat cartridges have small depth of pleats and big distance between their peaks. Cartridges are being installed in filters vertically. Intended for technological processes with high initial dust concentration (up to 20 g/m^3).



3. BAG AND SLEEVE TYPE FILTRATION ELEMENTS

JSC "SovPlym" uses three major types of sleeve and bag filters.

1. Straight (flat or round) sleeves on the solid frame. Intended for fiber and sticky types of dust and filtration systems with self-cleaning done either manually, by shaking or with compressed air.
2. Replaceable bag filters for oil mist. Intended for oil mist filtration systems when working with dense oils with possible admixtures of metal chips and other types of pollutants.
3. Ion-exchange bag filters from ion-exchange fabrics. Intended for toxic gases neutralization systems.



4. ACCUMULATIVE FILTRATION ELEMENTS

This type of filtration elements are usually used for industrial processes with low intensity of dust formation or occasional short time works. Filtration elements can be with various filtration class from G4 to HEPA. HEPA cartridges are only used as a final filtration stage and require obligatory filtration from coarse dust particles.



5. PRELIMINARY FILTRATION ELEMENTS

Preliminary filters are flat cartridges with non-woven material inside like aluminum or stainless wired net. Filtration class – G4. Intended use – protection of main fine filtration elements from coarse dust particles and other unwanted objects. In most of the cases preliminary filters can be washed and used over again.



6. WASHABLE ELECTROSTATIC ELEMENTS

During electrostatic filtration, particles get charged in ionization cell and settle on precipitation cell. Such filtration method has number of advantages:

- cells can be washed and used over again unlimited number of times;
- even smallest particles can be captured (including bacteria);
- well suitable for welding of oily metal parts;
- provide efficient filtration of oil smoke and mist.

Electrostatic filters can not be used for air, containing metal dust. Also, it is necessary to consider, that at increasing of airflow through the filter, filtration efficiency decreases.



7. FILTRATION ELEMENTS FROM ACTIVATED CARBON

Activated carbon cartridges are intended for cleaning the air from smells, ozone and some other gaseous components, formed during welding and soldering. Used as final filtration stage.



Special features of materials, used for cartridges for self-cleaning filtration systems

SovPlym manufactures and supplies wide range of filtration cartridges for various types of dust. Correct choice of filtration material is very important in order to provide estimated filtration efficiency and maximum service life of cartridges. When manufacturing cartridges for self-cleaning filtration systems, SovPlym uses following major types of materials:

- **Polyester (standard)**
- **Polyester with aluminum coating (antistatic)**
- **Polyester with PTFE membrane**
- **Polyester with PTFE membrane and antistatic coating**

NEW GENERATION MATERIALS SET NEW EFFICIENCY STANDARDS

PTFE membrane is the most modern and advanced filtration material for various technological processes and types of dust. Great properties and efficiency of this material are provided by special PTFE membrane, applied on the surface of polyester using special technology. Cartridges with PTFE membrane offer number of very important features:

- easier cleaning due to weak adhesion of dust to Teflon membrane;

- lower consumption of compressed air for cartridge cleaning process;
- higher efficiency in capturing of particles from 0,1 to 1 micron;
- longer life of cartridges due to surface filtration effect, when smallest pores of membrane do not let particles deep into the filtration material, thus preventing it's clogging;
- higher speed of filtration (airflow through the same filtration surface area) allows reducing size and cost of filter.



Standard polyester x 200



Standard polyester x 500

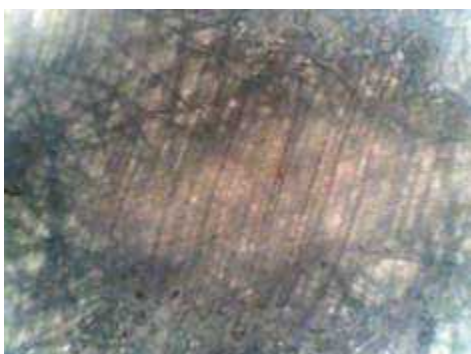

Polyester with PTFE membrane x 200

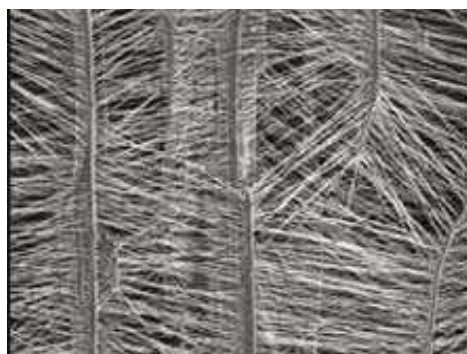

Polyester with PTFE membrane x 500

Difference between standard polyester and polyester with PTFE membrane can be well seen on the pictures above, which were made in SovPlym's own testing laboratory.

PTFE membrane stops smallest particles, with size down to 0,1 micron, from getting into inner layers of filtration material and settling there. The result is an increase in life time and filtration efficiency of cartridges.

On the picture, membrane is shown with wavy line.

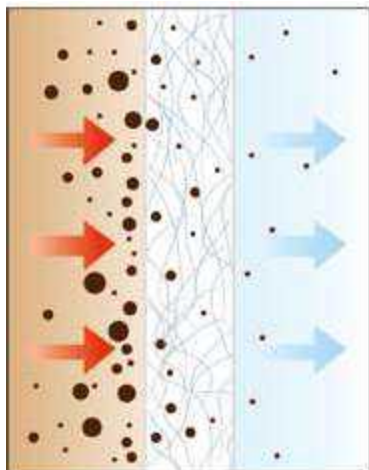

Standard polyester. Particles get deep inside the material and settle there.

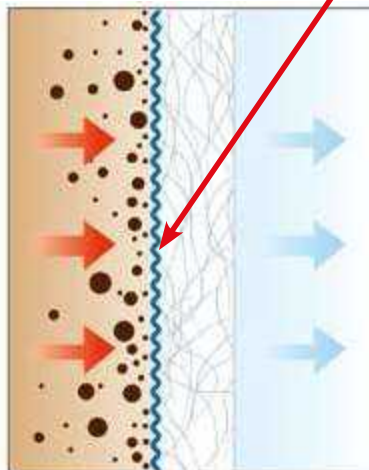

Major part of dust settles on the surface of PTFE membrane – surface filtration.

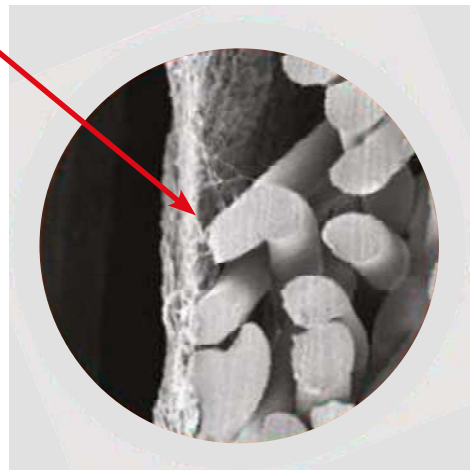

PTFE membrane. Even smallest particles of dust stay on the surface of the material.

Filtration efficiency of PTFE membrane is higher than similar standard filtration materials made of polyester with various density. Filtration efficiency goes up to 99,5% for particles with size from 0,1 to 3 microns, which are the most dangerous for inhaling, since they stay deep in lungs and provoke serious chronic diseases.

5 MOBILE FILTERS

DCA-P-200



Portable filter for soldering, equipped with activated carbon cartridge, for single extraction arm.

p. 41

DCA-P-300



Portable filter for soldering with low noise level, rpm adjustment, combined filter (HEPA, activated carbon), suitable for two extraction arms.

p. 42

DCSC-M1



Mobile mechanical self-cleaning filter for welding and grinding works, as well as other similar types of dust. Integrated automatic cleaning system works on the basis of timer. Requires external supply of compressed air.

p. 44

DCSC-M5



Mobile mechanical self-cleaning filter for welding and grinding processes, as well as other similar types of dust. Advantages: self-cleaning system with P-function; vertical easily removable filtration cartridge, integrated compressor, low noise level, mesh pre-filter.

p. 46

DCSC-M6



Mobile mechanical self-cleaning filter for welding and grinding processes, as well as other similar types of dust. Additionally equipped with activated carbon filter for removing of gases and smells. Increased productivity up to 2400 cmh. Design options: with two extraction arms for simultaneous work on two work places; with one extraction arm of increased diameter 200mm; with one standard extraction arm 160mm.

p. 49

EMK-1600



Mobile electrostatic filter for low intensity welding operations and welding of oily metal parts.

p. 53

DCA-P-200

PORTABLE FILTER



Description

Portable filter DCA-P-200 for single extraction arm or hose. Intended for cleaning the air from soldering smoke and low concentrations of dust. Allowed short time usage for welding works in case of conducting small repair works.

Intended use

- Laboratories.
- Temporary soldering work places.
- Renovation workshops.
- Repair departments.
- Training classes.

Limitations

Surrounding environment and cleaned airflow should not be explosive or contain aggressive substances, gases, decay and self-igniting materials.





Features and advantages

- Simple and durable design
- Small size
- Low noise level
- Delivery set with plug and cable for 220V, 50Hz
- Activated carbon filter included
- To be used with single extraction arm or hose

Technical characteristics

Article	Model	Max. productivity, cmh	Filtration surface, m ²	Filtration class	Power, kW	Noise level, dB	Inlet Ø	Weight, kg
DCA-P-200	5719	175	0,5	F9	1	71	1 x 100 mm	10

Replaceable cartridges and accessories

	Article	Model	Description
	6379	KKF *	Set of cartridges for DCA-P-200
	6378	DCAP-002	Activated carbon filter for DCA-P-200

*Filters are to be replaced as a set. One set includes for spare cartridges.

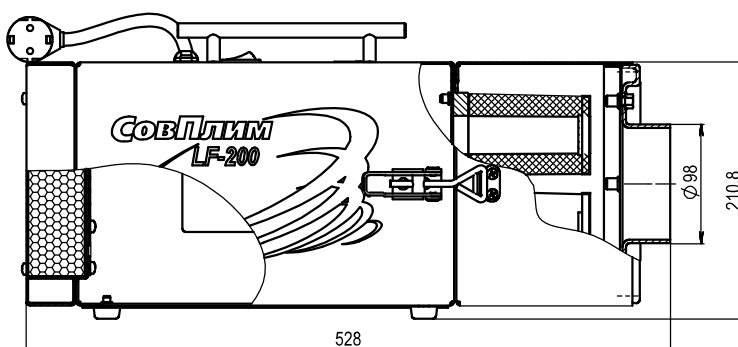
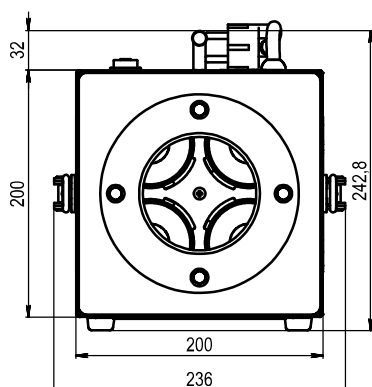

DCA-P-300

PORTABLE FILTER
FOR SOLDERING



Description

DCA-P-300 filter is a compact unit with low noise level, compact dimensions, intended for connection of one or two table top extraction arms or hoses. For optimal airflow set up, there is fine rpm adjustment with rotary knob.

Intended use

Due to low noise level, compact dimensions and convenient connection to extraction arms, DCA-P-300 is perfectly suitable for equipment of soldering work places at various industrial factories, training classes, laboratories, renovation workshops.

Limitations

Environment and cleaned airflow should not be explosive or contain aggressive substances, gases, decay and self-igniting materials.

Features and advantages

- Low noise level
- Low consumption of electricity
- Very compact
- Modern motor has no limitation for power on duration
- Optional work with one or two extraction arms
- Fast and easy replacement of filtration elements
- Filtration class H14
- Manual adjustment of productivity

Technical characteristics

Nominal capacity, cmh	Power supply voltage	Power consumption, kW	Dimensions, mm	Connection duct diameter, mm	Noise level, dB	Weight, kg	Body material	Max. negative pressure on the inlet, Pa
320	220 V, 50 Hz	0,17	335 x 370 x x 440	2 x 100	< 65	22	Powder coated steel	960

Pre-filter parameters (first stage of filtration)

Type	Material	Class of filtration
Prefilter	Fiberglass	F7

Parameters of combined filter (second stage of filtration)

Type	Material	Class of filtration
HEPA filter	Fiberglass	H14

Parameters of combined filter (third stage of filtration)

Type	Material
Chemical filter	Activated carbon

DCA-P-300 filtration principle

1. Coarse particles are being separated by pre-filter (filtration class F7);
2. Fine particles of smoke are being stopped by HEPA filter, which is a part of combined filter (filtration class H14);
3. Gaseous substances and smells are captured with activated carbon, also being a part of combined filter.

Major components of the filter:

1. Filter body
2. Fan
3. Inlets
4. Rough pre-filter
5. Mechanical filter
6. Carbon filter
7. Plug
8. Resistor
9. On/off switch

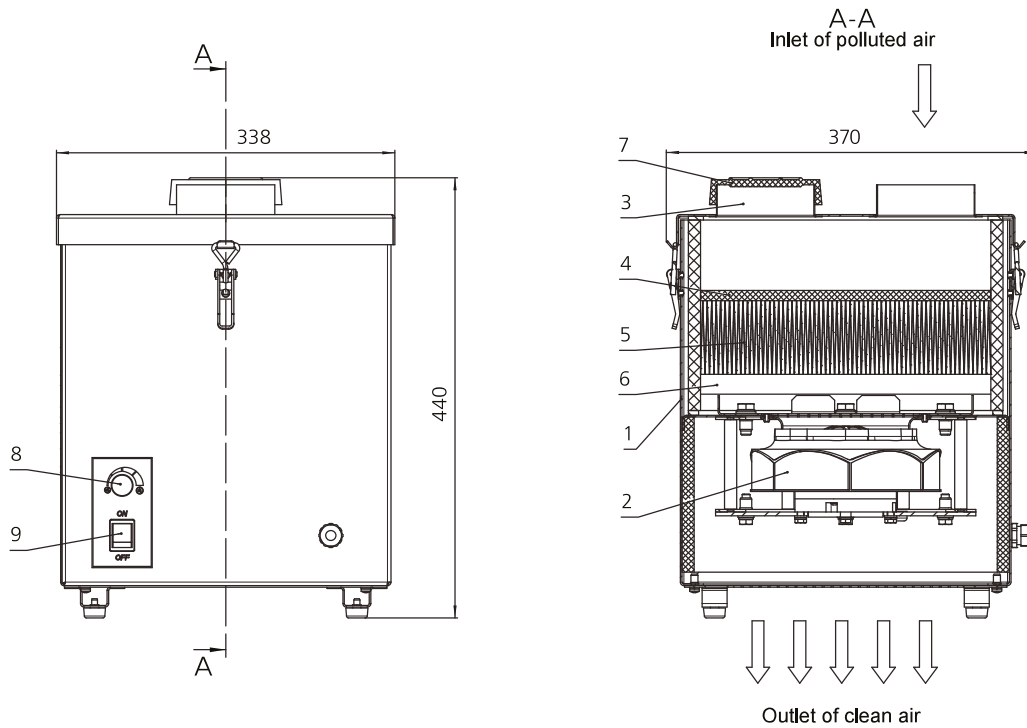

DCSC-M1

MOBILE MECHANICAL SELF-CLEANING FILTER



Description

DCSC-M1 filters are intended for local removal and cleaning of air from aerosols and dust particles, formed during welding, grinding, polishing of metals, and similar types of processing of various materials. DCSC-M1 is equipped with efficient system of automatic purging of filtration cartridge, which allows online cleaning without stopping the working process (at running fan). Cartridge cleaning system requires external connection of compressed air source. DCSC-M1 is designed for continuous work in closed premises.

Intended use

Units are specially designed for temporary and stationary work places in workshops of various industrial factories, laboratories, mechanical workshops, training and certification centers.

Limitations

Environment and cleaned airflow should not be explosive or containing aggressive substances, gases, decay and self-igniting materials.



Features and advantages

- Integrated system of automatic cleaning
- Horizontal filtration cartridge
- Timer based starting of self-cleaning with adjustment of frequency and length of pulses
- Long life time and easy replacement of filtration cartridge
- Convenient retractable dust tray
- Large coasters for various types of floors
- Simple maintenance (periodical cleaning of dust tray)

Technical characteristics

Article	Model	Max. airflow, cmh	Filtration material	Filtration surface area, m ²	Class of filtration	Power, kW	W-t, kg
27821	DCSC-M-1-TC12	1200	Polyester with PTFE membrane and antistatic coating	12	F9	1,1	135
27823	DCSC-M-1-T12		Polyester with PTFE membrane				

Delivery set

- Integrated fan
- Electrical cable with plug
- Control panel
- Filtration cartridge
- Oil and moisture separator with reducer for compressed air

NOT INCLUDED IN THE DELIVERY SET. TO BE ORDERED SEPARATELY:

extraction arm, air compressor, manometer

Extraction arms for DCSC-M1

Article	Model	Reach radius, m	Description
5359	BEA-M-2S	2	Standard extraction arm, diameter 160mm, without lighting.
6130	BEA-M-2SL		Extraction arm with lighting. Two buttons on the nozzle are use to switch the light and fan on and off.
5361	BEA-M-3S	3	Standard extraction arm, diameter 160mm, without lighting.
6131	BEA-M-3SL		Extraction arm with lighting. Two buttons on the nozzle are use to switch the light and fan on and off.
5363	BEA-M-4S	4	Standard extraction arm, diameter 160mm, without lighting.
6132	BEA-M-4SL		Extraction arm with lighting. Two buttons on the nozzle are use to switch the light and fan on and off.

Dimensions of DCSC-M1 filters

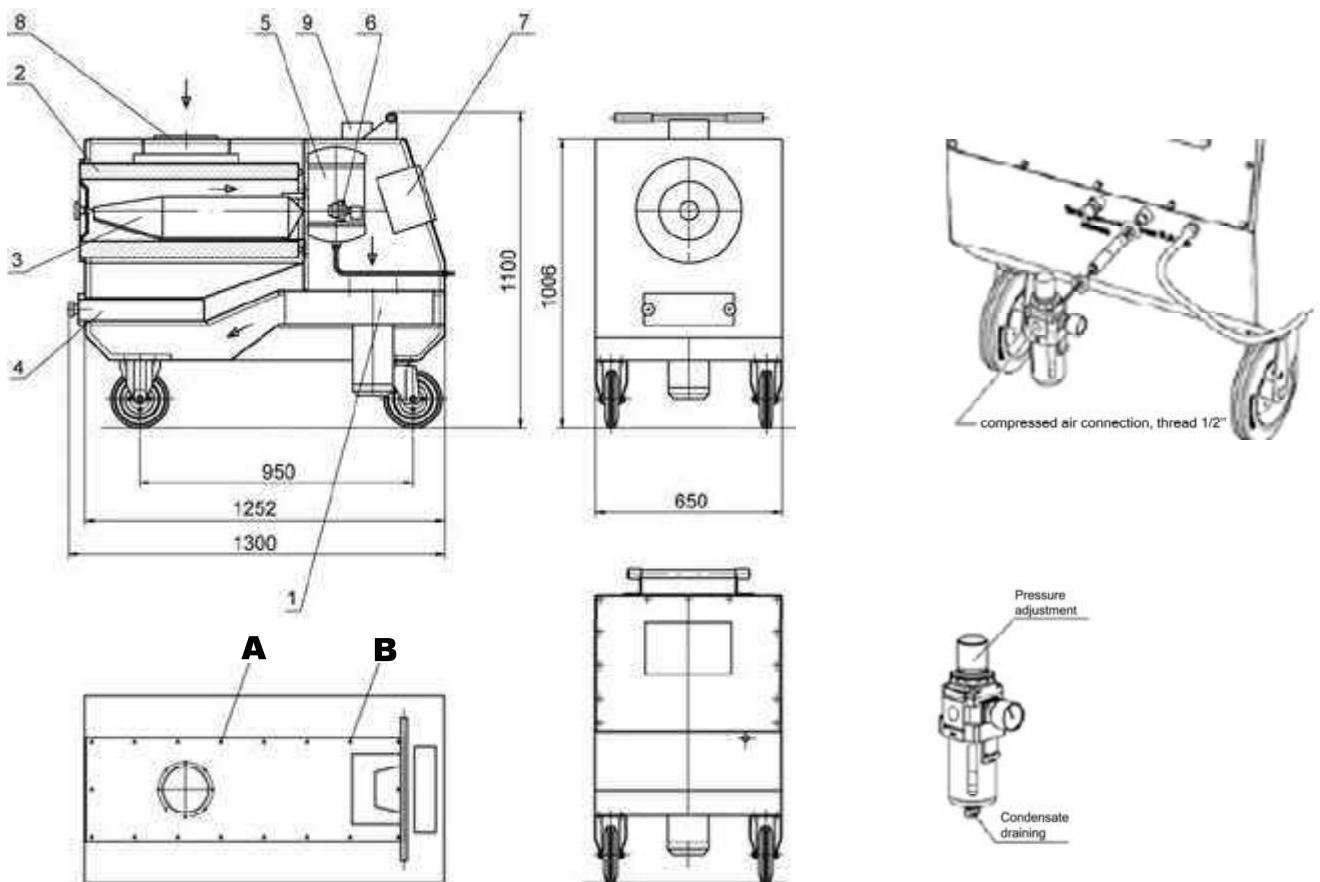

1. Fan
2. Filtration cartridge
3. Splitter
4. Dust tray
5. Receiver
6. Electromagnetic valve
7. Control box
8. Inlet
9. Terminal block

Connection of differential manometer (optional) for controlling the cartridge clogging level:

- A – connection point in "dirty" zone
- B – connection point in "clean" zone

DCSC-M5 | MOBILE MECHANICAL SELF-CLEANING FILTER



Description

DCSC-M5 series filters are intended for local extraction and cleaning of air from aerosols and dust particles, formed during welding, grinding, polishing of metals and similar types of processing of various materials.

Major distinguishing design features of these units are: compact dimensions; low noise level; special cartridge fixing mechanism for fast and easy replacement of vertical cartridge; controller with integrated differential manometer, starting the cartridge cleaning process at reaching estimated pressure drop value (P-function); integrated oil-free compressor (for DCSC-M5-K-xxx models) for work in location where no external supply of compressed air is available.

Units have two stages of protection (mesh pre-filter and metal screen shield), decreasing the risk of sparks hitting the filter.

Intended use

Units are specially designed for temporary and stationary work places in workshops of various industrial factories, laboratories, mechanical workshops, training and certification centers.

Limitations

Surrounding environment and cleaned airflow should not be explosive and/or containing aggressive vapors and gases, particles inclined to decay and/or self-igniting.



Features and advantages

- Compact body design.
- High productivity – 1200 cmh at low power consumption – 1,1 kW.
- Low noise level – 66 dB.
- Vertical, easily removable cartridge with high filtration class.
- Integrated oil-free compressor (for DCSC-M5-K models).
- Programmable logical cartridge cleaning control system with ΔP -function, prolonging life time of filtration cartridge and decreasing consumption of electricity and compressed air.
- Two-stage protection from sparks, decreasing the chance of fire.
- Top side exit for clean air.
- Filter control buttons are duplicated on extraction arm nozzle (option).
- Sound and LED indication of maximum cartridge clogging.

Technical characteristics

Characteristic	Models	
	DCSC-M5-K-xxx (with integrated compressor)	DCSC-M5-xxx (w/out integrated compressor)
Maximum airflow, cmh	1200	
Diameter of suitable extraction arm, mm	160	
Max. reach radius of suitable extraction arm, m	2 / 3 / 4	
Integrated motor power, kW	1,1	
Power source voltage, V/Hz/Ph	230 / 50 / 1	
Active filtration surface area, m ²	12	
Compressor power, kW	0,5	-
Dimensions, mm	655 x 770 x 1455	
Noise level, dB	66	
Weight (w/out extraction arm), kg	180	150

Production range of units

Article	Model	Cartridge model	Delivery scope
Filter type: with integrated compressor			
5825	DCSC-M5-K-T12	CART-V-T12	Delivery scope includes: - integrated oil-free compressor for air; - vertical filtration cartridge with air splitting insert; - integrated fan; - control box with ΔP -function, sound and LED indication transformer for BEA extraction arms with lighting; - pre-filter; - cartridge protection shield screen; - electrical cable with european plug; To be ordered separately: - extraction arm BEA-M-XS; - cartridge precoating powder Preco-N in the amount of 0,5 kg per 12 m ² (only for CART-V-D12 filtration cartridges).
5826	DCSC-M5-K-TC12	CART-V-TC12	
5827	DCSC-M5-K-D12	CART-V-D12	
Filter type: without integrated compressor			
5829	ПМCФ-5-T12	CART-V-T12	Delivery scope includes: - vertical filtration cartridge with air splitting insert; - integrated fan; - control box with ΔP -function, sound and LED indication transformer for BEA extraction arms with lighting; - pre-filter; - cartridge protection shield screen; - oil and moisture separator for compressed air with reducer and manometer; - electrical cable with european plug; To be ordered separately: - air compressor (in case of absence of compressed air network) - extraction arm BEA-M-XS; - cartridge precoating powder Preco-N in the amount of 0,5 kg per 12 m ² (only for CART-V-D12 filtration cartridges).
5837	ПМCФ-5-TC12	CART-V-TC12	
5838	ПМCФ-5-D12	CART-V-D12	

Types of extraction arms, used together with mobile units

Article	Model	Name	Description	Reach radius, m	Ducts diameter, mm	Nozzle diameter, mm
Extraction arms with lighting						
6130	BEA-M-2SL	Extraction arm with lighting, w/out control box	Gaz intake nozzle with two buttons: 1) Nozzle lighting on/off 2) Mobile unit integrated fan on/off	2	160	300
6131	BEA-M-3SL			3		
6132	BEA-M-4SL			4		
Extraction arms without lighting						
5359	BEA-M-2S	Lifting-rotary extraction arm		2	160	300
5361	BEA-M-3S			3		
5363	BEA-M-4S			4		

Attention! Extraction arm BEA-M is not included in delivery scope for mobile unit. Required type of extractio arm should be ordered separately.

Production range and characteristics of replaceable filtration cartridges.

Article	Model	Description	Filtration class
Pre-filter (included in the delivery set)			
6969	FF-DCSC-M5	Washable. Included in the delivery set.	G3
Vertical filtration cartridge, 12 m² (included in the delivery set)			
6953	CART-V-T12	Polyester with PTFE membrane	E11
6954	CART-V-TC12	Polyester with PTFE membrane and antistatic coating	E11
6956	CART-V-D12	Polyester	F9
Cartridge precoating powder (option, not included in the delivery set, should be ordered separately for CART-V-D12 cartridges)			
18079	Preco-N	Cartridge precoating powder, 1 kg. Consumption 0,5 kg per 12 m ²	
7331	Preco-N	Cartridge precoating powder, 12 kg. Consumption 0,5 kg per 12 m ²	

Dimensions and connections

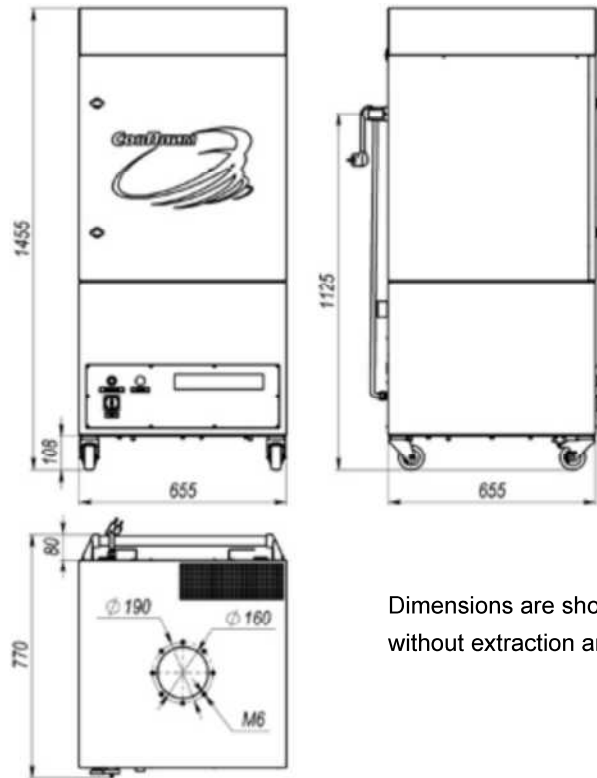

Dimensions are shown without extraction arm

Major components

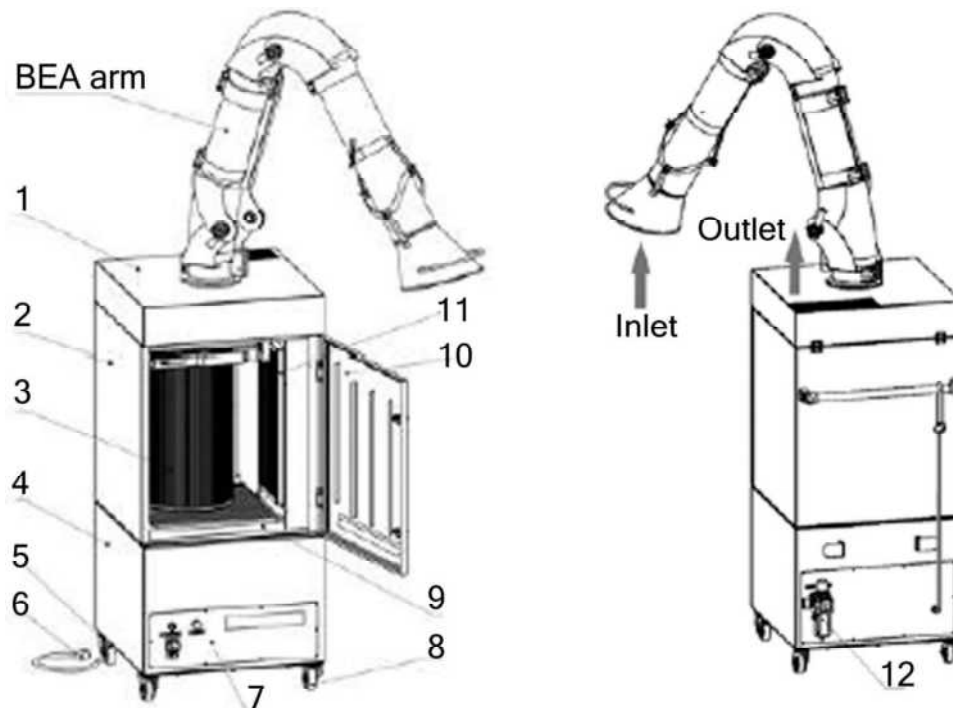

- 1. Cover
- 2. Filter body
- 3. Filtration cartridge
- 4. Fan body
- 5. Rotary wheel
- 6. Power cable with plug

- 7. Control panel
- 8. Coaster with lock
- 9. Dust tray
- 10. Door
- 11. Mesh pre-filter
- 12. Oil and moisture separator

DCSC-M6

MOBILE MECHANICAL SELF-CLEANING FILTER



Description

Mobile filter DCSC-M6 (without integrated compressor) and DCSC-M6-K (with integrated compressor) are intended for local removal and cleaning of air from aerosols and dust, formed during welding, grinding, polishing and similar types of processing of various materials.

Major distinguishing features of DCSC-M6 series filters are: increased productivity, models for installation of two extraction arms, compact dimensions, low noise level, top side outlet for clean air (grid on the top cover of the filter), two oval cartridges, optional activated carbon filter, integrated oil-free compressor. New controller with integrated differential manometer automatically starts cartridge cleaning process only when cartridge clogging reaches estimated value (ΔP -function). DCSC-M6 units have two stage of protection (mesh pre-filter and two metal screen shields) decreasing the risk of sparks getting into the filter.

Intended use

DCSC-M6 units are designed for work at temporary and stationary work places in workshops of various industrial factories, laboratories, mechanical workshops, training and examination facilities.

Limitations

Surrounding environment and cleaned airflow should not be explosive and/or containing aggressive vapors and gases, particles inclined to decay and/or self-igniting.



Features and advantages

- High productivity – up to 2400 cmh at low power consumption – 1,5 kW.
- Compact body.
- Low noise level – 75 dB.
- Two flat oval cartridges with total filtration surface area of 24m².
- Optional integrated oil-free compressor.
- Advanced automatic cleaning system with ΔP -function (increasing life time of cartridges, decreasing power and compressed air consumption).
- Two stage protection from sparks, decreasing the risk of fire.
- Top side outlet for clean air.
- Filter control buttons on the extraction arm's nozzle.
- Sound and LED indication of maximum cartridge clogging.
- Convenient retractable dust tray.

Technical characteristics

Parameter	Value
Maximum airflow, cmh	2400
Diameter of number of suitable extraction arm, mm	1 x 160 / 2 x 160 / 1 x 200
Max. reach radius of suitable extraction arm, m	2 / 3 / 4
Integrated motor power, kW	1,5
Power source voltage, V/Hz	220, 50 Hz
Active filtration surface area, m ²	24 (2 x 12m ²)
Additional cleaning stage	Carbon filter
Filtration cartridge material	PTFE membrane
Class of filtration	F9
Compressor power, kW	0,5
Dimensions, mm	775 x 775 x 1525
Noise level, dB	74
Weight (w/out extraction arm), kg	185

Production range of units

Mobile mechanical self-cleaning filter DCSC-M6-K (with integrated compressor)

Delivery set includes mobile filter DCSC-M6, preassembled with following major components:

- integrated oil-free compressor;
- flat oval filtration cartridge, 2x12m2;
- integrated fan in noise reduction jacket;
- control box with ΔP -function, sound and LED indication, transformer for BEA extraction arms with lighting;
- mesh washable pre-filter (set of 2pcs);
- protective metal screen shields – 2 pcs;
- electrical cable L=5m with euro plug

Article	Model	Cartridge model	Delivery set
DCSC-M6-160-K series with one extraction arm BEA-M (Ø160 mm) and integrated compressor			
501036	DCSC-M6-160-K-T12	CART-OV-T12	To be ordered separately: - extraction arm BEA-M-xS(L) - 1 pcs; - cartridge precoating powder Preco-N in the amount of 1 kg per 24 m ² (only for filtration cartridges CART-OV-D12)
501037	DCSC-M6-160-K-TC12	CART-OV-TC12	
501038	DCSC-M6-160-K-D12	CART-OV-D12	
DCSC-M6-2x160-K series with two extraction arms BEA-M (Ø160 mm) and integrated compressor			
501044	DCSC-M6-2x160-K-T12	CART-OV-T12	To be ordered separately: - extraction arm BEA-M-xS(L) - 2 pcs; - cartridge precoating powder Preco-N in the amount of 1 kg per 24 m ² (only for filtration cartridges CART-OV-D12)
501045	DCSC-M6-2x160-K-TC12	CART-OV-TC12	
501046	DCSC-M6-2x160-K-D12	CART-OV-D12	
DCSC-M6-200-K series with one extraction arm BEA-200 (Ø200 mm) and integrated compressor			
501052	DCSC-M6-200-K-T12	CART-OV-T12	To be ordered separately: - extraction arm BEA-200-xS(L) – 1pcs; or BEA-200-xS-450 – 1pcs; - cartridge precoating powder Preco-N in the amount of 1 kg per 24 m ² (only for filtration cartridges CART-OV-D12)
501053	DCSC-M6-200-K-TC12	CART-OV-TC12	
501054	DCSC-M6-20-K-D12	CART-OV-D12	

Mobile mechanical self-cleaning filter DCSC-M6 (without integrated compressor)

Delivery set includes mobile filter DCSC-M6, preassembled with following major components:

- flat oval filtration cartridge, 2x12m2;
- integrated fan in noise reduction jacket;
- control box with ΔP -function, sound and LED indication, transformer for BEA extraction arms with lighting;
- mesh washable pre-filter (set of 2pcs);
- protective metal screen shields – 2 pcs;
- electrical cable L=5m with euro plug

Article	Model	Cartridge model	Delivery set
DCSC-M6-160 series with one extraction arm BEA-M (Ø160 mm)			
501032	DCSC-M6-160-T12	CART-OV-T12	To be ordered separately: - extraction arm BEA-M-xS(L) - 1 pcs; - cartridge precoating powder Preco-N in the amount of 1 kg per 24 m ² (only for filtration cartridges CART-OV-D12) - compressor (if there is no compressed air network)
501033	DCSC-M6-160-TC12	CART-OV-TC12	
501034	DCSC-M6-160-D12	CART-OV-D12	
DCSC-M6-2x160 series with two extraction arms BEA-M (Ø160 mm)			
501040	DCSC-M6-2x160-T12	CART-OV-T12	To be ordered separately: - extraction arm BEA-M-xS(L) - 2 pcs; - cartridge precoating powder Preco-N in the amount of 1 kg per 24 m ² (only for filtration cartridges CART-OV-D12) - compressor (if there is no compressed air network)
501041	DCSC-M6-2x160-TC12	CART-OV-TC12	
501042	DCSC-M6-2x160-D12	CART-OV-D12	
DCSC-M6-200-K series with one extraction arm BEA-200 (Ø200 mm)			
501048	DCSC-M6-200-T12	CART-OV-T12	To be ordered separately: - extraction arm BEA-200-xS(L) – 1pcs; or BEA-200-xS-450 – 1pcs; - cartridge precoating powder Preco-N in the amount of 1 kg per 24 m ² (only for filtration cartridges CART-OV-D12) - compressor (if there is no compressed air network)
501049	DCSC-M6-200-TC12	CART-OV-TC12	
501050	DCSC-M6-200-D12	CART-OV-D12	

Production range of extraction arm, used with DCSC-M6 filters

Attention! Extraction arms BEA are not included in the delivery set of mobile filters. Required type of extraction arm BEA must be chosen and ordered separately, according to the following table.

Article	Model	Name, description	Reach radius, m	Duct diameter, mm	Nozzle diameter, mm
Extraction arms Ø160. BEA-M-xSL series (with lighting)					
6130	BEA-M-2SL	Extraction arm with lighting without control box, with 2 buttons on the nozzle: 1)nozzle lamp on/off; 2)mobile filter fan on/off.	2	160	290
6131	BEA-M-3SL		3		
6132	BEA-M-4SL		4		
Extraction arms Ø160. BEA-M-xS series (without lighting)					
5359	BEA-M-2S	Lifting-rotary extraction arm	2	160	290
5361	BEA-M-3S		3		
5363	BEA-M-4S		4		
Extraction arms Ø200. BEA-200-xSL series (with lighting)					
5906	BEA-200-2SL	Extraction arm with lighting without control box, with 2 buttons on the nozzle: 1)nozzle lamp on/off; 2)mobile filter fan on/off.	2	200	330
5907	BEA-200-3SL		3		
5908	BEA-200-4SL		4		
Extraction arms Ø200. BEA-200-xS series (without lighting)					
5311	BEA-200-2S	Lifting-rotary extraction arm	2	200	330
5312	BEA-200-3S		3		
5313	BEA-200-4S		4		
Extraction arms Ø200. BEA-200-xS-450 series (with increased extraction nozzle Ø450 mm without lighting)					
5909	BEA-200-2S-450	Lifting-rotary extraction arm with increased nozzle Ø450 mm	2	200	450
5910	BEA-200-3S-450		3		
5911	BEA-200-4S-450		4		

Options and consumables

Article	Model	Description	Filtration class
Activated carbon filter (optional, not included in delivery set, to be ordered separately)			
6011	CF-006	Filter for cleaning the air from toxic gases and smells.	M5
Pre filter (optional, not included in delivery set, to be ordered separately)			
6673	FF-006	Washable. Set consists of 2pcs. (installed separately over each cartridge. Not included in the delivery set.	G3
Oval filtration cartridge (q-ty - 2pcs., included in the delivery set of DCSC-M6)			
600008	CART-OV-T12	Polyester with PTFE membrane	E11
600009	CART-OV-TC12	Polyester with PTFE membrane and antistatic coating	E11
600010	CART-OV-D12	Polyester	F9
Cartridge pre-coating powder (option, not included in the delivery set, to be ordered separately for CART-OV-D12 cartridges)			
18079	Preco-N	Cartridge precoating powder, 1 kg. Consumption 1kg per 24 m ²	
7331	Preco-N	Cartridge precoating powder, 12 kg. Consumption 1kg per 24 m ²	

**Dimensions and connections.
Major components.**

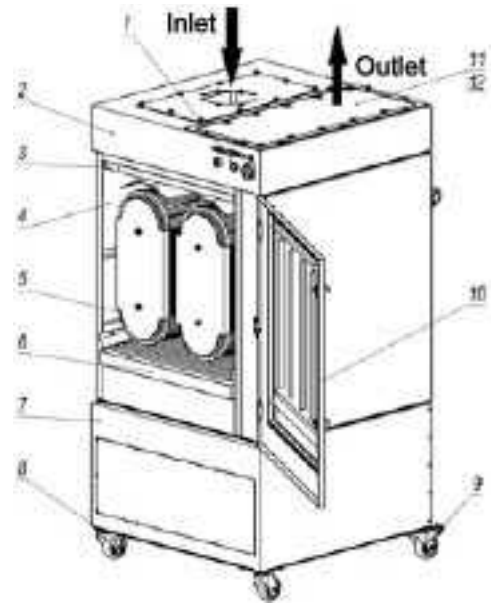
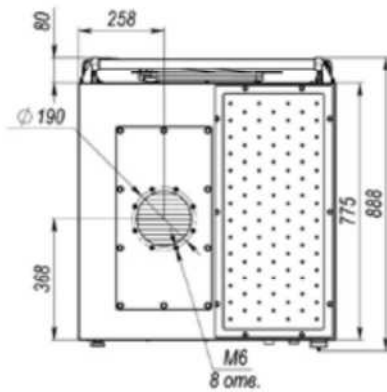
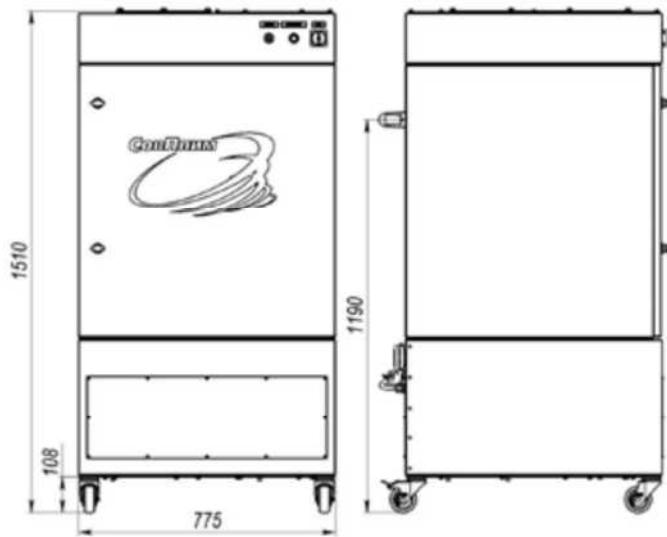

1. Control panel
2. Filter cover
3. Pre-filter
4. Filter body
5. Cartridge, 2x12 m²
6. Dust bin
7. Filter body
8. Rotary coaster
9. Rotary coaster with brake
10. Door
11. Grid for vertical outlet of clean air (optional installation of activated carbon filter under the grid)

EMK-1600

MOBILE ELECTROSTATIC FILTER



Description

Mobile electrostatic filter EMK is intended for cleaning the air from aerosols, formed during welding of either clean or oily metals at non-stationary work places. There is an option for installation of one or two extraction arms, including ones with lighting and buttons on the nozzle (fan starting is done only with the button on the unit, lighting is turned on only with the button on the nozzle). Activated carbon filter CF-002 for cleaning the air from toxic gases and smells can be also installed as an option.

Intended use

- Various industrial factories
- Oily metal welding processes
- Welding workshops
- Training classes

Limitations

- Not suitable for cleaning of air, containing metal dust.
- Not recommended for intensive welding.

Features and advantages

- Optional design for two work places.
- Integrated protection.
- LED indication of filtration cell saturation.
- Washable filtration cells.
- Activated carbon filter (optional).
- 5m long cable with euro plug for 220 V, 50 Hz.
- No consumables required except activated carbon filter.
- Large coasters for rough floors.



Technical characteristics

Article	Model	Max. airflow, cmh	Filtration surface, m ²	Filtration efficiency	Number of connections for extraction arms	Weight, kg
5473	EMK-1600c	1500	16,4	>92%	1	120
5475	2EMK-1600c				2	

Extractopm arms for EMK

Article	Model	Reach radius, m	Lighting
5359	BEA-M-2S	2	-
6130	BEA-M-2SL		yes
5361	BEA-M-3S	3	-
6131	BEA-M-3SL		yes
5363	BEA-M-4S	4	-
6132	BEA-M-4SL		yes

Dimensions and connections

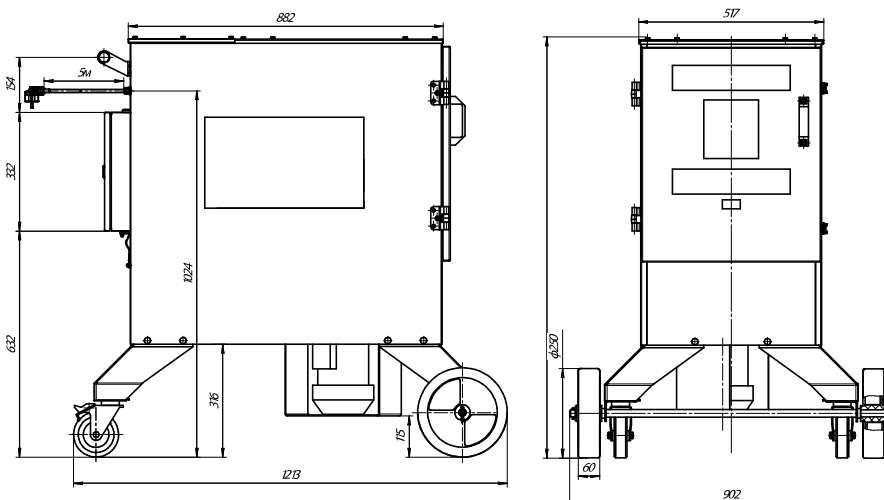

Delivery set

- Integrated fan
- Rotary coasters 2pcs (1pcs with brake)
- Non rotary coasters 2pcs
- Electrical cable with plug L=5m
- Control panel
- Prefilter
- Ionization cartridge
- Precipitation cartridge
- Activated carbon filter (optional)

ATTENTION!

Extraction arm and activated carbon filter are not included in the delivery set. Required model of extraction arm and activated carbon filter, if required, are to be ordered separately.

6 STATIONARY FILTERS

DCSC-W5



Wall mounted self-cleaning filter with vertical cartridge, integrated fan in noise reduction jacket and outlet for clean air on top side, integrated compressor, intended for welding, grinding, polishing and similar types of dust. For single extraction arm Ø160mm.

page 56

DCSC-W2



Wall mounted self-cleaning filter with two vertical cartridges, integrated fan in noise reduction jacket and outlet for clean air on top side, intended for welding, grinding, polishing and similar types of dust. For single extraction arm Ø200mm or two extraction arms Ø160mm.

page 60

DCSC-S



Modular self-cleaning filter with horizontal cartridges for thermal cutting, welding, grinding and polishing of metals, as well as other similar processes involving various materials. Recommended initial concentration of dust – up to $2\text{g}/\text{m}^3$. Available in various configurations.

page 63

MDV



Modular self-cleaning filter with vertical cartridges for thermal cutting, welding, grinding and polishing of metals, as well as other similar processes involving various materials. Options: with integrated fan in noise reduction jacket and without integrated fan. Recommended initial concentration of dust – up to $2\text{g}/\text{m}^3$.

page 72

Push Pull



Stationary technical solutions for welding processes of large scale parts, basing on the principles of organization of circulating air flows and their cleaning in the entire volume of workshop (for workshops up to 24m wide when using push grids, and up to 50m wide – with nozzles).

page 77

Diluter



Mobile technical solutions for welding processes of large scale and long parts, basing on the principles of organization of circulating air flows and their cleaning in the entire volume of workshop or it's specific parts (for workshops up to 50m wide).

page 78



MT-3X/MT-4X

Mechanical stationary filter with replaceable spare cartridges of accumulative type for soldering, laser engraving and marking, contact welding and similar types of fumes. Filter has several standard sets, which vary on combination and number of filtration stages (from 2 to 4): pre-filter G3, main filter F9, HEPA filter H13, activated carbon filter M5.

page 81



MT-3X/X MT-4X/X

Modular mechanical stationary filter with replaceable spare cartridges of accumulative type. These filters are modifications of single modules MT-3X and MT-4X. Standard configurations start with 5000cmh and go up to 12500cmh.

page 84



MIF

Ion-exchange module for gaseous components, allocated during some types of welding and thermal cutting of metals.

page 87

DCSC-W5

WALL MOUNTED SELF-CLEANING FILTER



Description

DCSC-W5 series filters are intended for local extraction and cleaning of air from aerosols and dust particles, formed during processes of welding, grinding, polishing of metals and similar operation with various types of materials.

Major design features of DCSC-W5 are: compact design, low noise level, special cartridge fixing mechanism for fast replacement of vertical cartridge, controller with integrated differential pressure, starting cartridge cleaning process at reaching of estimated pressure drop value - ΔP function, integrated oil free compressor (for DCSC-W5-K model) for work places where connection of compressed air is complicated or impossible.

Units have two stages of protection (net pre-filter and metal screen shield) for preventing coarse particles, slag, shavings and similar foreign objects from hitting the cartridge directly.



Intended use

Units are specially developed for usage at stationary work places in workshops of various industrial factories, laboratories, mechanical workshops, training and educational facilities.

Limitations

Environment and cleaned air should be non explosive, containing no aggressive vapor and gases or particles inclined to smoldering or self-igniting.

Features and advantages

- High productivity – 1200cmh at low energy consumption of 1,1kW;
- Compact body;
- Low noise level – 68dB;
- Vertical easy removable cartridge with high cleaning class;
- Programmable logical control system with ΔP function, prolonging service life of filtration cartridge and decreasing consumption of electricity and compressed air;
- LED and sound indication of maximum cartridge clogging;
- Simple cartridge fixing system for easy maintenance;
- Integrated oil free compressor (for DCSC-W5-K models);
- Two-stage protection from coarse particles, scale and shavings;
- Top-side outlet for clean air;
- Filter control buttons duplicated on the nozzle of the extraction arm (option).

Production range and technical parameters

Name of the parameter or characteristic	Value of the parameter	
	DCSC-W5-F	DCSC-W5-F-K
Maximum airflow, cmh	1200	
Supply power voltage, V/Hz/Ph	400/50/3	
Integrated fan's motor power, kW	1,1	
Max. consumption of compressed air, l/min of free air: · factory default setting (1 pulse/min.) · manual setting (up to 3 pulses/minute)	45 135	
Pressure of supplied compressed air (working), MPa (bar)	0,5 – 0,55 (5,0 – 5,5)	–
Quality of compressed air according to GoSt 17433-80	class 9	–
Filtration class according to DIN EN 779-93	F9	
Filtration class according to DIN EN 60335-2-69	M	
Noise level not more than, dB	68	
Inlet diameter, mm	160	
Body dimensions (HxWxL), mm	655x655x1524	
Weight, not more than, kg (without extraction arm)	160	180
Protection class IEC 60529:2013	IP54	
Working regime	continuous	
Type of compressor / power of integrated compressor, kW	oil free/ 0,5	



Product range

Article	Model	Cartridge type
Wall mounted self-cleaning filter with integrated fan in noise reduction jacket and compressor DCSC-W5-F-K		
5946	DCSC-W5-F-K-T12	CART-V-T12
5947	DCSC-W5-F-K-TC12	CART-V-TC12
5948	DCSC-W5-F-K-D12	CART-V-D12
Wall mounted self-cleaning filter with integrated fan in noise reduction jacket and DCSC-W5-F (without integrated compressor)		
5942	DCSC-W5-F-T12	CART-V-T12
5943	DCSC-W5-F-TC12	CART-V-TC12
5944	DCSC-W5-F-D12	CART-V-D12

Delivery set:

- integrated fan
- integrated compressor (for DCSC-W5-F-K models)
- oil and moisture separator OMS with reducer and manometer (DCSC-W5-F models)
- control box with ΔP function, LED and sound indication and transformer for extraction arms BEA with lighting
- electrical cable with plug with grounding
- vertical filtration cartridge with air splitting insert (see table below)
- mesh pre-filter (see table below)

Product range and characteristics of replaceable filtration cartridges

Sketch	Article	Model	Description	Filtration class
Vertical filtration cartridge (one is included in the delivery set)				
	6953	CART-V-T12	Polyester with PTFE membrane	E11
	6954	CART-V-TC12	Polyester with PTFE membrane and antistatic coating	E11
	6956	CART-V-D12	Polyester	F9
Pre-filter (optional)				
	6969	FF-DCSC	Washable. Optional	G3

To be ordered separately:

BEA-M extraction arms for installation on DCSC-W5

Article	Model	Reach radius, m	Diameter, mm	Description
5351	BEA-M-2H	2	160	Extraction arm without lighting
5355	BEA-M-3H	3		
5356	BEA-M-4H	4		
6124	BEA-M-2HL	2		Extraction arm with lighting and 2 buttons on the inlet nozzle: 1) to switch on the lighting lamp on the inlet nozzle 2) to switch on the fan of DCSC-W5 filter
6125	BEA-M-3HL	3		
6126	BEA-M-4HL	4		

Precoating powder for CART-V-D12 cartridges

(optional, not included in the delivery set, to be ordered separately for CART-V-D12 cartridge)

	Article	Model	Description
	18079	Preco-N	Cartridge precoating powder, 1kg. Consumption 1kg per 24m ²
	7331	Preco-N	Cartridge precoating powder, 12kg. Consumption 1kg per 24m ²

Dimensions and connections.

General view of the filter and major components.

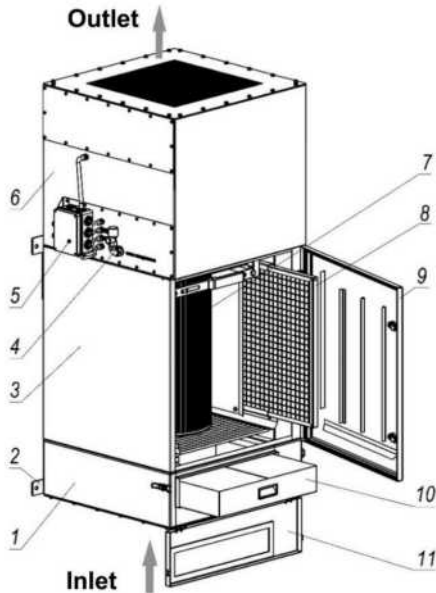

- 1. inlet chamber;
- 2. wall mounting eyes;
- 3. filter module body;
- 4. safety valve;
- 5. terminal box;
- 6. fan body;
- 7. cartridge;
- 8. pre-filter;
- 9. filter door;
- 10. dust bin;
- 11. inlet chamber door.

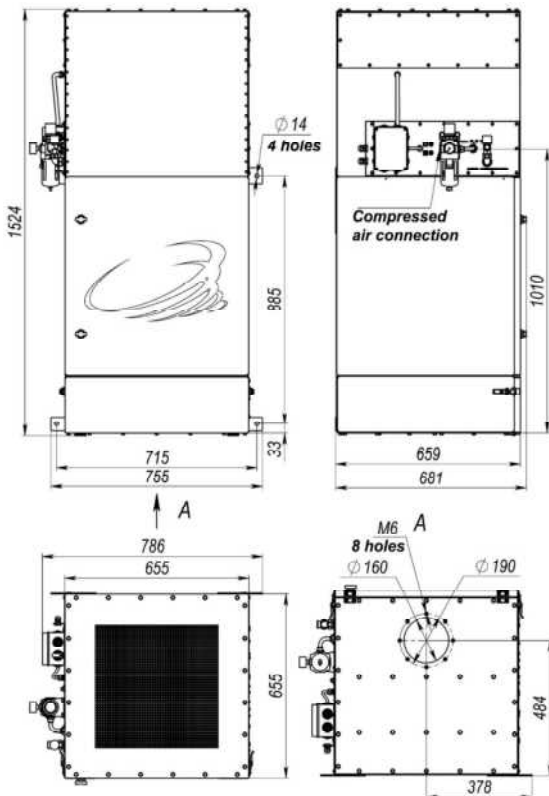

DCSC-W5-F dimensions

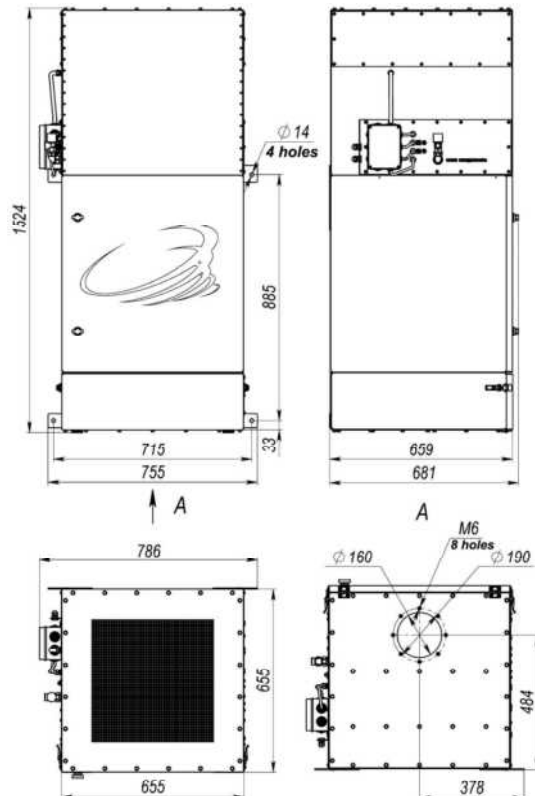

DCSC-W5-F-K dimensions



Additional components for DCSC-W5

Sketch	Article	Model	Name, Description.
	6081	CP-160	Connection flange for DCSC-W-1/2x160. Intended for connection of extraction arm's hose, installed separately from DCSC-W5, or ducting of extraction system Ø160 mm.
	6700	FS-DCSC-W5	On floor support for DCSC-W5 Dimensions (L x W x H): 835 x 1006 x 2791 mm Two levels of mounting for the filter, providing height of rotary flange for BEA-M-XX extraction arm equal to 935 or 1820 mm. Height of DCSC-W5-F on support (two levels): 2791, 3335 mm.

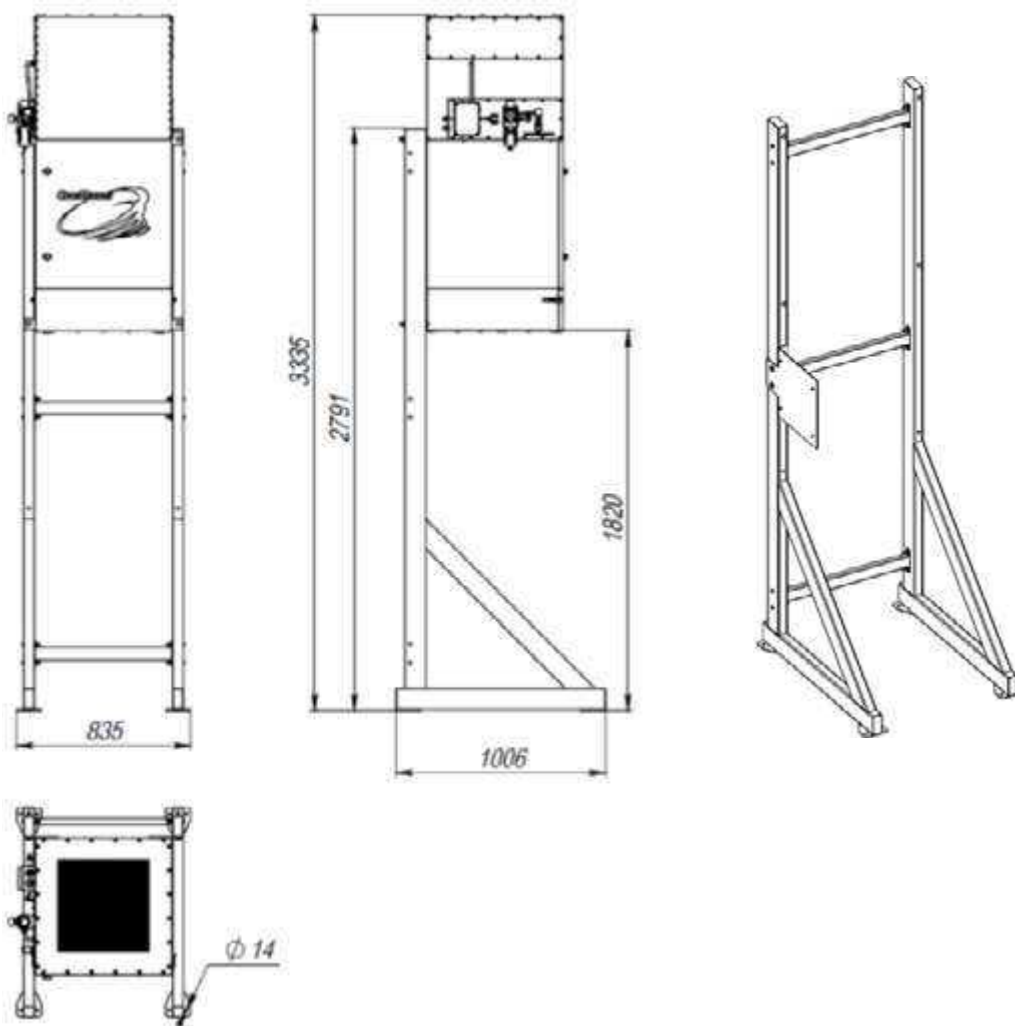
Dimensions and connections for floor support

DCSC-W2

WALL MOUNTED SELF-CLEANING FILTER



Description

Wall mounted self-cleaning filter DCSC-W2 with vertical cartridges for welding processes, grinding and other types of dust with initial concentration up to 2 g/m³. Supplied with integrated fan in noise reduction jacket. Doesn't require installation of silencer due to special design of the outlet. Clean air is directed straight upwards, avoiding air drafts and providing convenient working conditions for staff. Units are manufactured in two optional types: for connection of one or two extraction arms of 160mm or for one extraction arm with diameter of 200mm. Filter can be installed on standards floor support.

Intended use

Units are specifically designed for stationary workplaces at various industrial factories, laboratories, mechanical workshops, training centers.

Limitations

Working environment and cleaned airflow should not be explosive and contain no aggressive vapors and gases, as well as particles prone to decay and self-ignition.



Features and advantages

- Durable design
- Wall mounted design
- Suitable for standard extraction arms
- Integrated fan
- New control box with ΔP -function

Technical parameters

Name of the parameter or characteristics	Value of the parameter
Maximum airflow, cmh	2400
Filtration surface area, m ²	2 x 12
Power consumption of the control box (not more than), kW	0,1
Power source voltage, V/Hz/Ph	380/50/3
Integrated fan power, kW	4,0
Noise level (not more than), dB	75
Filtration class DIN EN 779-93	F9
Filtration class DIN EN 60335-2-69	M
Filter body dimensions (WxDxH), mm	1300x850x1892
Weight of the filter, kg (without extraction arm)	200

Dimensions

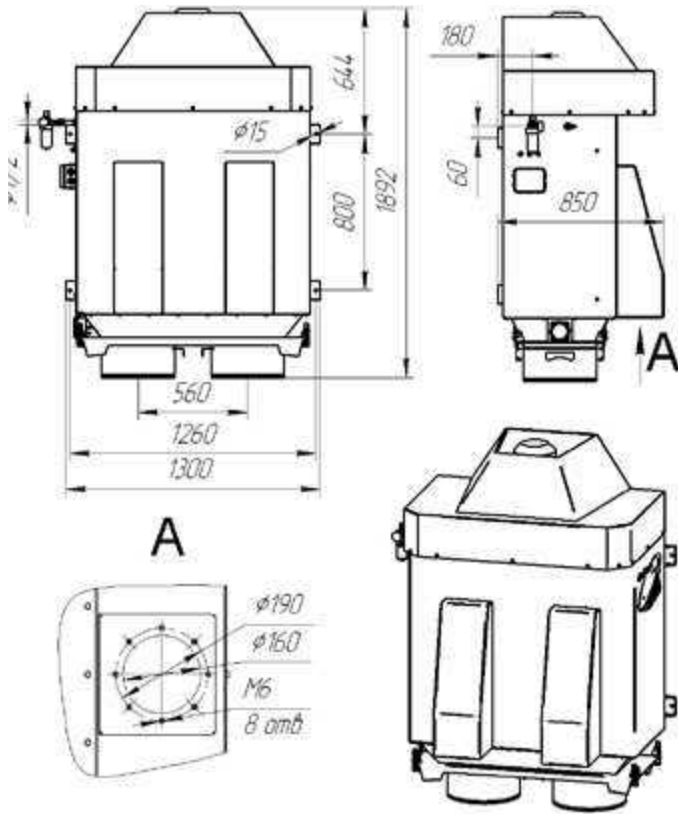

DCSC-W2x160

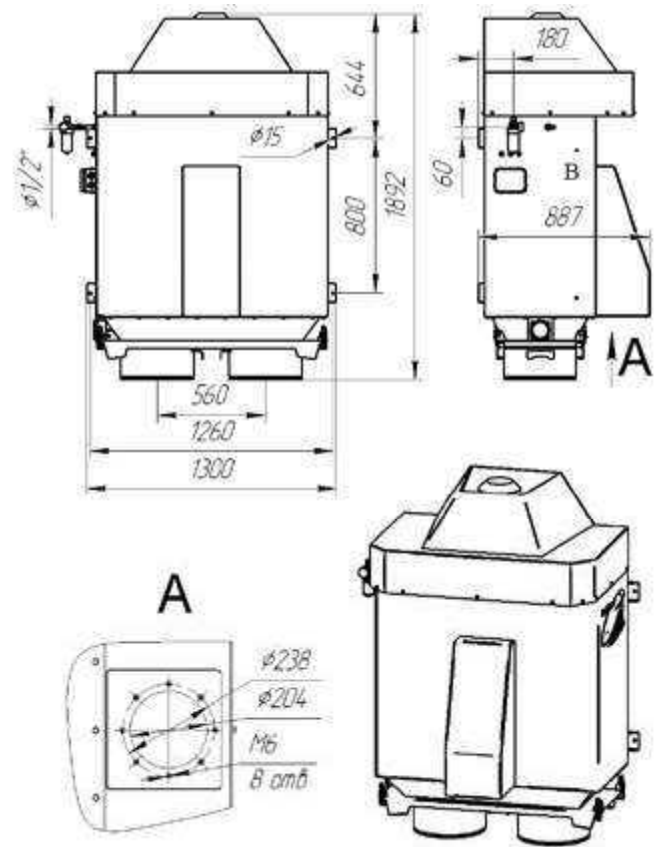



DCSC-W-200

Production range and characteristics of spare filtration cartridges

Article	Model	Cartridge type	Delivery set
27743	DCSC-W2x160-00-T12	CART-T12	<p>Included in the delivery set:</p> <ul style="list-style-type: none"> • control box (including starter and thermal relay for the fan); • integrated fan in noise reduction jacket; • 2 hanging dust bins 6 liters each; • 2 filtration cartridges; • oil and moisture separator with reducer for compressed air; • differential manometer with bracket.
27783	DCSC-W200-00-T12	CART-T12	<p>To be ordered separately:</p> <ul style="list-style-type: none"> • extraction arms (2pcs Ø160mm for code 27743 or 1pcs Ø200mm for 27783), which are being fixed directly on the filter or on the wall next to it; • air compressor (required if there is no factory network of compressed air 5,5 – 6 atm); • connectors CD-160 (for code 27743) or CB-200 (for code 27783), if extraction arms are being fixed next to the filter.

Sketch	Article	Model	Description	Filtration class
Filtration cartridge (one is included in the delivery set)				
	6903	CART-T12	Active filtration surface 12 m ²	F9 – DIN EN 779; M – DIN EN 60335

Additional components for DCSC-W2 and DCSC-W200

Sketch	Article	Model	Name. Description.
	6081	CD-160	Connection duct for DCSC-W1/2x160. Intended for connection of the hose of extraction arm, which is mounted separately from DCSC-W2 or ventilation system duct Ø160 mm.
	6339	CD-200	Connection duct for DCSC-W200. Intended for connection of the hose of extraction arm, which is mounted separately from DCSC-W2 or ventilation system duct Ø2000 mm.
	6034	FS-DCSC-W 200/2x160	Support for DCSC-W200/2x160 filters. Height 2800 mm.

Dimensions and connections of the support

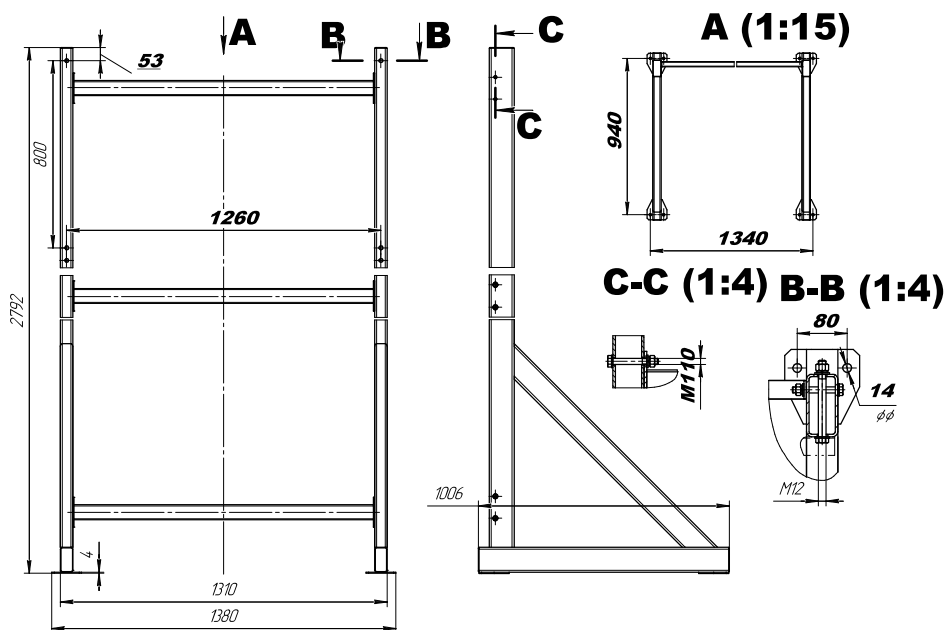

DCSC-S

MODULAR SELF-CLEANING CARTRIDGE FILTER



Description

Modular self-cleaning cartridge filters of DCSC-S series are industrial stationary filtration units with large variety of modification with productivity from 600 to 64000cmh.

DCSC-S filters are intended for cleaning the air from aerosols of plasma, laser, gas cutting and welding of metals, as well as other types of non-sticky, non-fiber, non-explosive dust and fumes.

Specific feature of DCSC-S is modular design, which allows choosing optimal capacity and dimensions of filter, suitable for any size of premises: with limited space or low ceilings, narrow hallways etc.

Compact dimensions and low weight of basic modules allow delivery and assembly of DCSC-S filters in places, where access to hoisting equipment is limited or not available.

New controller with integrated differential manometers starts cleaning of filtration cartridges only when clogging level reaches estimated value (ΔP -function).



Intended use

DCSC-S filters are intended for industrial usage at various machine building, metal processing, metallurgical, chemical, mining, electronic, food, pharmaceutical and other factories.

Limitations

Surrounding environment and cleaned air should not be explosive or/and contain aggressive vapors and gases as well as particles inclined to decay or self-igniting.

Features and advantages

- Modular design with large number of configurations with various capacity and dimensions
- Possibility of adding modules in case of increased capacity requirements
- Various options for installation of inlets and outlets for convenient connection to ventilation system ducting
- Steel mesh pre-filters (optional)
- Integrated metal screen shields for cartridge protection from coarse particles
- Full size door at each module for easy access for observation and replacement of filtration cartridges without any tools
- Inspection door on the back side of each module for simple maintenance of pneumatic cleaning system
- Choice of four types of filtration materials for various technological processes and maximum cleaning efficiency, also increasing service life of cartridges
- New controller with integrated electronic differential pressure gauge and text display, showing current pressure drop (cartridge clogging level)
- Smart system of automatic cartridge cleaning with ΔP -functions, prolonging cartridge service life and decreasing power consumption and consumption of compressed air
- Final cleaning function after switching the fan off
- Special design of air splitting insert inside each cartridge, providing even distribution of air and cleaning of complete cartridge surface area (same as with vertical cartridges) and longer service life of the cartridge
- New design of mobile dust bins with fast clamping mechanism for direct connection to hopper
- Optional installation of sliding valve for dust unloading from the dust bin without switching off the fan
- Oil and moisture separator with pressure regulator and manometer for compressed air

General technical parameters

Name of the parameter of characteristic	Parameter value
Max concentration of dust at the inlet, g/m ³	2*
Filtration class DIN EN 779-93	F9
Filtration class DIN EN 60335-2-69	M
Max. pressure drop ΔP , Pa - for cartridges D and C; - for cartridges T and TC	1500 1800
Control box power supply voltage, V/Hz/Ph	240/50/1
Control box power, W	100
Power supply for electromagnetic valve, V	~24
Temperature of cleaned air flow, °C	до 80
Dust bin capacity, litres	70
Compressed air working pressure, MPa (bar)	0,5-0,55 (5,0-5,5)
Compressed air connection	1/2' (inner thread)
Compressed air cleanliness grade	9
Compressed air consumption, l/min of free air	
DCSC-S-2 – DCSC-S-12: - at factory default settings (pulse frequency: 2p./min) - maximum (pulse frequency: 6 p./min)	100 l of free air/min 300 l of free air/min
DCSC-S-16 – DCSC-S-24: - at factory default settings (pulse frequency: 2p./min) - maximum (pulse frequency: 6 p./min)	200 l of free air/min 600 l of free air/min
DCSC-S-32 – DCSC-S-36: - at factory default settings (pulse frequency: 2p./min) - maximum (pulse frequency: 6 p./min)	300 l of free air/min 900 l of free air/min
DCSC-S-48 - at factory default settings (pulse frequency: 2p./min) - maximum (pulse frequency: 6 p./min)	400 l of free air/min 1200 l of free air/min
DCSC-S-64 - at factory default settings (pulse frequency: 2p./min) - maximum (pulse frequency: 6 p./min)	600 l of free air/min 1800 l of free air/min

* When initial concentration of dust exceeds 2g/m³, preliminary filtration units are mandatory to be installed before the filter. Recommended models are CPO cyclone, vertical preseparator VPS or similar.

Production range. Technical parameters.

Article	Model	Max. airflow (cmh)	Number of cartridges	Filtration surface area, m ²	Number of pre-filters BPF-S / BPF	Max. weight, kg
27883	DCSC-S-2-T12-FD	2000	2	24	1 / 0	280
27303	DCSC-S-2-T12					210
27552	DCSC-S-4-T12-FD	4000	4	48	0 / 1	360
27313	DCSC-S-4-T12					280
27559	DCSC-S-6-T12-FD	6000	6	72	1 / 1	420
27323	DCSC-S-6-T12					350
27566	DCSC-S-8-V-T12-FD	8000	8	96	0 / 2	490
27333	DCSC-S-8-V-T12					420
27343	DCSC-S-8-H-T12					520
27353	DCSC-S-10-V-T12	10000	10	120	1 / 2	510
27363	DCSC-S-12-T12					650
27383	DCSC-S-12-V-T12	12000	12	144	0 / 3	550
27373	DCSC-S-12-H-T12				0 / 3	830
27393	DCSC-S-16-T12	16000	16	192	0 / 2	780
27413	DCSC-S-16-V-T12				0 / 4	720
27403	DCSC-S-16-H-T12				0 / 4	1130
27423	DCSC-S-18-T12				18000	18
27433	DCSC-S-20-T12	20000	20	240	1 / 2	920
27453	DCSC-S-24-V-T12					24000
27443	DCSC-S-24-H-T12	32000	32	384	0 / 4	1210
27473	DCSC-S-32-V-T12				0 / 8	1450
27463	DCSC-S-32-H-T12	36000	36	432	0 / 4	1560
27483	DCSC-S-36-T12				0 / 6	1610
27503	DCSC-S-48-V-T12	48000	48	576	0 / 8	2010
27493	DCSC-S-48-H-T12				0 / 6	2060
27513	DCSC-S-64-T12				64000	64

Naming:

«**FD**» – optional design for direct installation of FD-series fans on top cover of the filter (fan type to be chosen and ordered separately)

«**T-12**» – type of filtration cartridges installed in the filter*

«**V**» – vertical orientation of filter's body shape (for premises with high ceilings and less floor space occupation)

«**H**» – horizontal orientation of filter's body shape (for low ceiling premises)

No «V» or «H» index – square body shape

*** Notes**

DCSC-S filters are being supplied with CART-T12 cartridges (polyester with PTFE membrane, 12m²), intended for thermal cutting and welding applications. For other technological processes, it is mandatory to order filter with suitable type of cartridges (refer to cartridge description table). When ordering the filter, put required cartridge index instead of "T12" in the filter model.

Sample of filter articles with other types of cartridges: DCSC-8-V-C12-FD; DCSC-12-V-D12.

Attention! In order to avoid any possible mistakes when ordering DCSC-S filters for any applications, it is recommended to get assistance from representatives of JSC "SovPlym".

List of filtration cartridges. Description. Application.

Model	Index / material	Application	Features
Standard cartridges with 12 m² of filtration surface area			
CART-D12	D-12 / Polyester	Welding aerosols, including welding of oily metals. Dust with oil traces.	Precoating with Preco-N is mandatory (not less than 500g per 1 cartridge)
		Various types of dust with prevailing particle size over 0.5 microns.	Precoating with Preco-N is recommended (not less than 500g per 1 cartridge)
CART-T12	T-12 / Polyester with PTFE membrane	Dry welding aerosols, soldering smoke. Dry plasma, laser and gas cutting aerosol. Various type of fine dust with prevailing particle size below 0.5 microns.	Captured dust and aerosols should not contain oil particles. Precoating is not required. For heavy working regimes. Longest cartridge life time.
CART-TC12	TC-12 / Polyester with PTFE membrane and aluminium coating	Various types of dust with prevailing particle size below 0.5 microns, capable to static charge accumulation.	
CART-C12	C-12 / Polyester with aluminium coating	Used only with antistatic version of filters.	
Cartridges with increased filtration surface, 15m². Used for processes with low initial dust concentration.			
CART-D15	D-15 / Polyester	Welding aerosols, including welding of oily metals. Dust with oil traces.	Precoating with Preco-N is mandatory (not less than 500g per 1 cartridge)
		Various types of dust with prevailing particle size over 0.5 microns.	Precoating with Preco-N is recommended (not less than 500g per 1 cartridge)
CART-T15	T-15 / Polyester with PTFE membrane	Dry welding aerosols, soldering smoke. Dry plasma, laser and gas cutting aerosol. Various type of fine dust with prevailing particle size below 0.5 microns.	Captured dust and aerosols should not contain oil particles. Precoating is not required. Longest cartridge life time.
CART-TC15	TC-15 / Polyester with PTFE membrane and aluminium coating	Various types of dust with prevailing particle size below 0.5 microns, capable to static charge accumulation.	
CART-C15	C-15 / Polyester with aluminium coating	Used only with antistatic version of filters.	
Special cartridge with filtration surface 10m². Used for heavy working regimes (three shifts work, initial concentration over 2g/m ³ and others).			
CART-T10	T-10 / Polyester with PTFE membrane	Dry welding aerosols, soldering smoke. Dry plasma, laser and gas cutting aerosol. Various type of fine dust with prevailing particle size below 0.5 microns.	Captured dust and aerosols should not contain oil particles. Precoating is not required. Longest cartridge life time.

Recommendations on airflow per one 12m² cartridge for some of the most common industrial processes

Name of the process	Recommended airflow*, cmh	Recommended type of CART cartridge
Initial dust concentration at filter entrance should not exceed 2g/m³.		
Welding	500	D12 + Preco-N
	800	T12
Plasma cutting	430 – 500	T12
Laser cutting	500 – 580	T12
Gas cutting	580	T12
Metal spraying	300 – 500	T12
Shot- and sand-blasting	750	D12
Polishing of metals	500 – 750	T12, D12+ Preco-N
Cutting and polishing of fiberglass, PVC and similar materials	500 – 800	TC12, C12

* Airflow values, stated in the table, are approximate and should be confirmed considering special features of every technological process, size and properties of dust particles. For more detailed information on recommended loads (airflow) and usage of DCSC-S filters for various technological processes please contact specialists of JSC “SovPlym”.

Pre-filter

In order to protect filtration cartridges from direct hit of coarse particles, metal shield screens are integrated into the filter design, which are installed at the entrance into the dirty zone of the filter right after the inlets. Second feature of these screens is even distribution of airflow inside of the filter.

When using the filter for some technological processes, additional protection from coarse particles and foreign objects might be required. For such situations there is a provision in DCSC-S for installation of pre-filters BPF-S (small) and BPF (basic). They are being installed between the filter’s body and inlet as it is shown on the picture. Pre-filters are not included in the delivery set and are being ordered separately. Required number of pre-filters is shown in Table “Production range. Technical parameters.”

Production range of pre-filters

(optional, not included in DCSC-S delivery set)

Drawing	Article	Model	Name
	6352	BPF	Pre-filter for installation of basic 4-cartridge modules BM-4. Consists of the body and replaceable, washable cartridge made of multilayer stainless mesh. Dimensions of the body 890x330x109mm.
	6952	BPF-S	Small pre-filter for installation of basic 2-cartridge modules BM-2. Consists of the body and replaceable, washable cartridge made of multilayer stainless mesh. Dimensions of the body 440x330x109mm.

Contents of BPF, BPF-S pre-filters

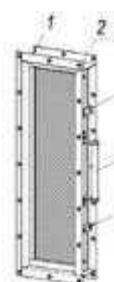

1. Body
2. Cartridge (replaceable mesh prefilter)
3. Nuts
4. Fixing rod with handle

Installation of pre-filter BPF, BPF-S

Inlet Sealing Pre-filter DCSC-S



Control boxes

Control of the automatic cartridge cleaning system is done via series of control boxes CONT on the basis of KF-3 controller, supplied with DCSC-S filters.

CONT-M control box



Control box CONT-M (main) is a KF-3 controller installed in a plastic box with transparent cover. Protection class IP54. Controller has integrated differential manometer for ΔP -function control and displaying of current pressure drop value. ΔP -function automatically starts cartridge cleaning process when pressure drop (cartridge clogging) reaches estimated value.

KF-3 controller has two outputs for remote control of:

- emergency condition of the controller or pneumatic valves;
- reaching of maximum cartridge clogging level;

and one output for:

- starting of cartridge cleaning cycle after fan stop

KF-3 controller has two working regimes:

- 1 – automatic (cleaning on estimated pressure drop (ΔP -function));
- 2 – manual (continuous cleaning with preset frequency and length of pulses).

KF-3 controller allows adjustment of following parameters (factory default values)

Parameter	Name in controller's menu	Value
Pulse length, s	P.LENGTH	0,3
Pause length, s	PAUSE LENGTH	30
Number of cleaning cycles after fan stop	CYCLES	10
Activation on pressure drop ΔP , Pa	dP START	1000
Deactivation on pressure drop $\Delta P - \Delta P$ -HYSTER, Pa	dP HYSTER	200
Emergency setting of maximum pressure drop ΔP for cartridges, Pa	dP ALARM	1500 for D, C 1800 for T, TC

Number of controlling outputs - 12. Number of connected channels 24 (maximum two valves can be connected to one output). If filter has more than 24 valves, additional control box CONT-S (secondary) is being connected. Such control box is included in the delivery set of corresponding DCSC-S filters and, due to 12 outputs, allows connection of additional 24 valves.

Control box CONT-S



CONT-S control box is a KF-3 secondary module, installed in the plastic box with transparent cover. Protection class IP54. This controller acts as 12 contacts extension module (for 24 valves). Secondary KF-3 controller doesn't have own led display and works only together with main KF-3 module.

Control box CONT-NMSF2

Control box CONT-NMSF2 is a KFC-2 controller, installed in a metal drawer with a lockable door. On the door there are buttons "Power", "Fan", "Cleaning" and LED indicators: green for power and red for alarm. Control box is equipped with starter with thermal relay for the 4kW fan motor (adjustment range 7-10 A). Protection class IP54.

Control box has same functions and settings as CONT-M, but has two outputs for pneumatic valves control.

Overall table of control boxes CONT, supplied with DCSC-S filters

Drawing	Model	Brief description. Function.
	CONT-NMSF2	Control box, based on two-channel controller KFC-2 with ΔP -function and text display, supplied with starter and thermal relay for 4kW fan motor. Supplied with all types of following filters: DCSC-S-2, DCSC-S-2-FD
	CONT-M	Control box, based on twelve-channel controller KF-3 (main) with ΔP -function and text display. Supplied with all types of following filters: DCSC-S-4, DCSC-S-4-FD and up to DCSC-S-64.
	CONT-S	Control box, based on twelve-channel controller KF-3 (secondary). Works only together with KF-3 (main). Allows connection of additional 24 valves. Single main module allows connection of up to 8 secondary modules. Set of CONT-S (1pcs) + CONT-M (1pcs) is supplied with all filters from DCSC-S-32 up to DCSC-S-48. Set of CONT-S (2pcs) + CONT-M (1pcs) is supplied with all filters DCSC-S-64. Supplied with all types of following filters: DCSC-S-4, DCSC-S-4-FD and up to DCSC-S-64.

Delivery scope

Standard delivery set of DCSC-S filters includes following basic components in the amount, corresponding to filter configuration:

- basic modules BM-2 and (or) BM-4;
- filtration cartridges;
- inlets and outlets;
- hopper;
- support frame set;
- dust bin;
- sliding valve;
- control box CONT;
- control box mounting bracket;
- pneumatic connection kit CAF;
- oil and moisture separator for compressed air with reducer and manometer.

To be ordered separately:

- extraction fan;
- starter for fan motor with thermal relay and additional contact (to start cleaning cycle after fan shut down), or frequency inverter, or fan control box;
- pre-filters BPF, BPF-S;
- pre-separator VPS, cyclone CPO or similar spark arrestors;
- air compressor;
- support for on floor installation of control box CONT.

Dimensions and connections for all standard configurations of DCSC-S filters

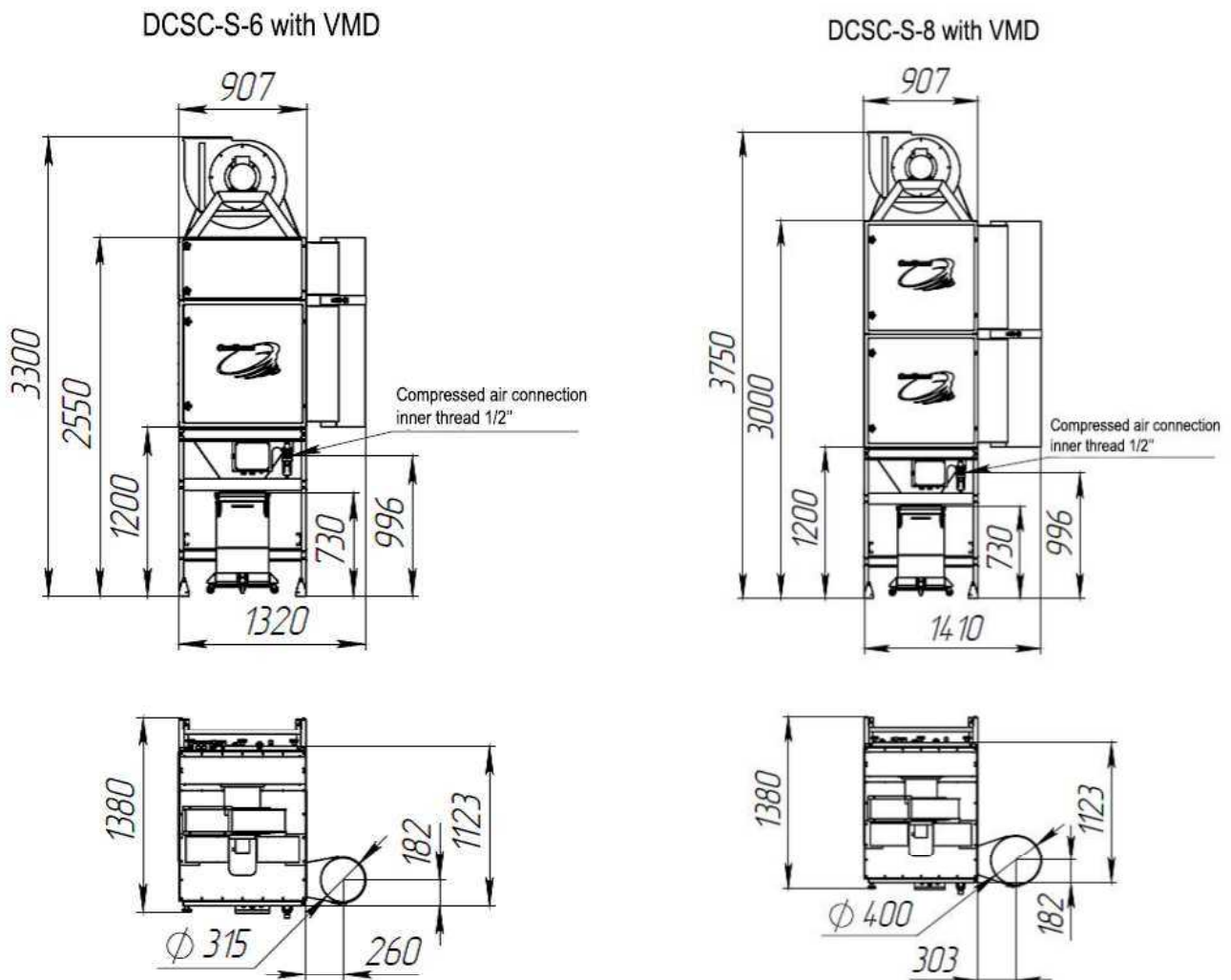
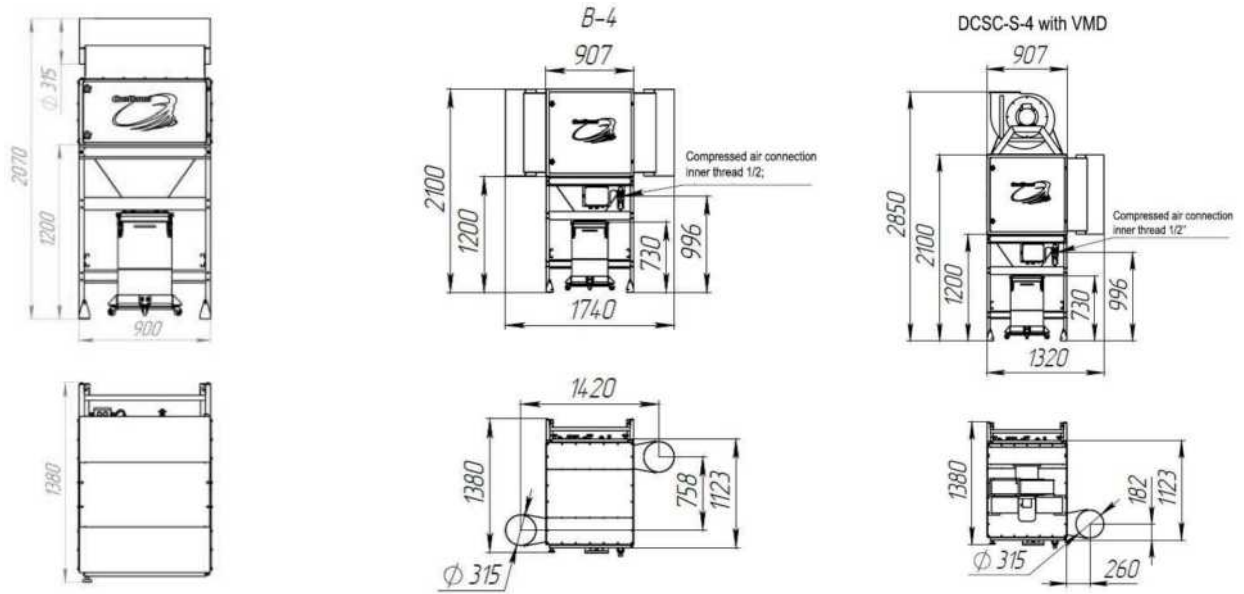

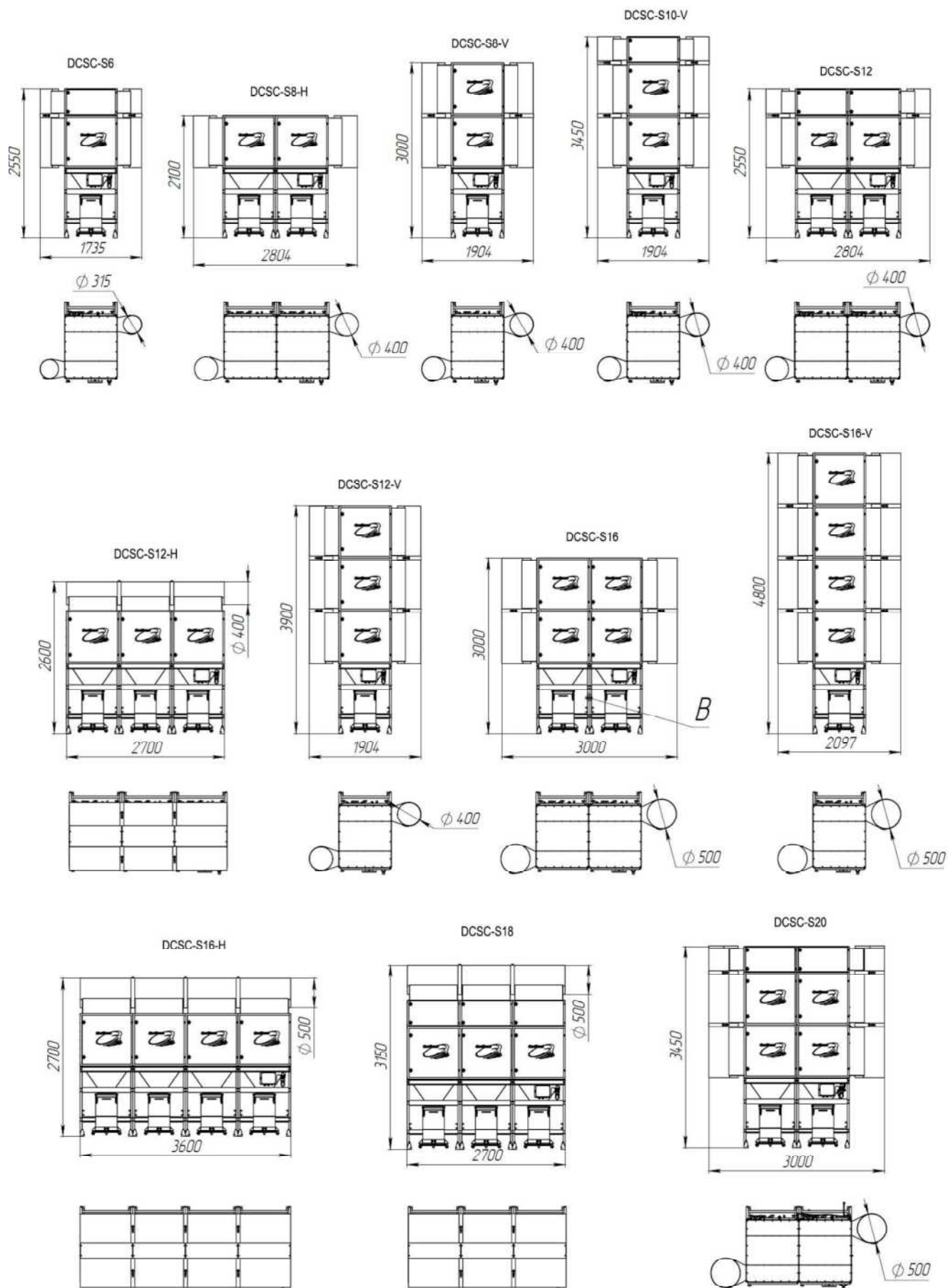

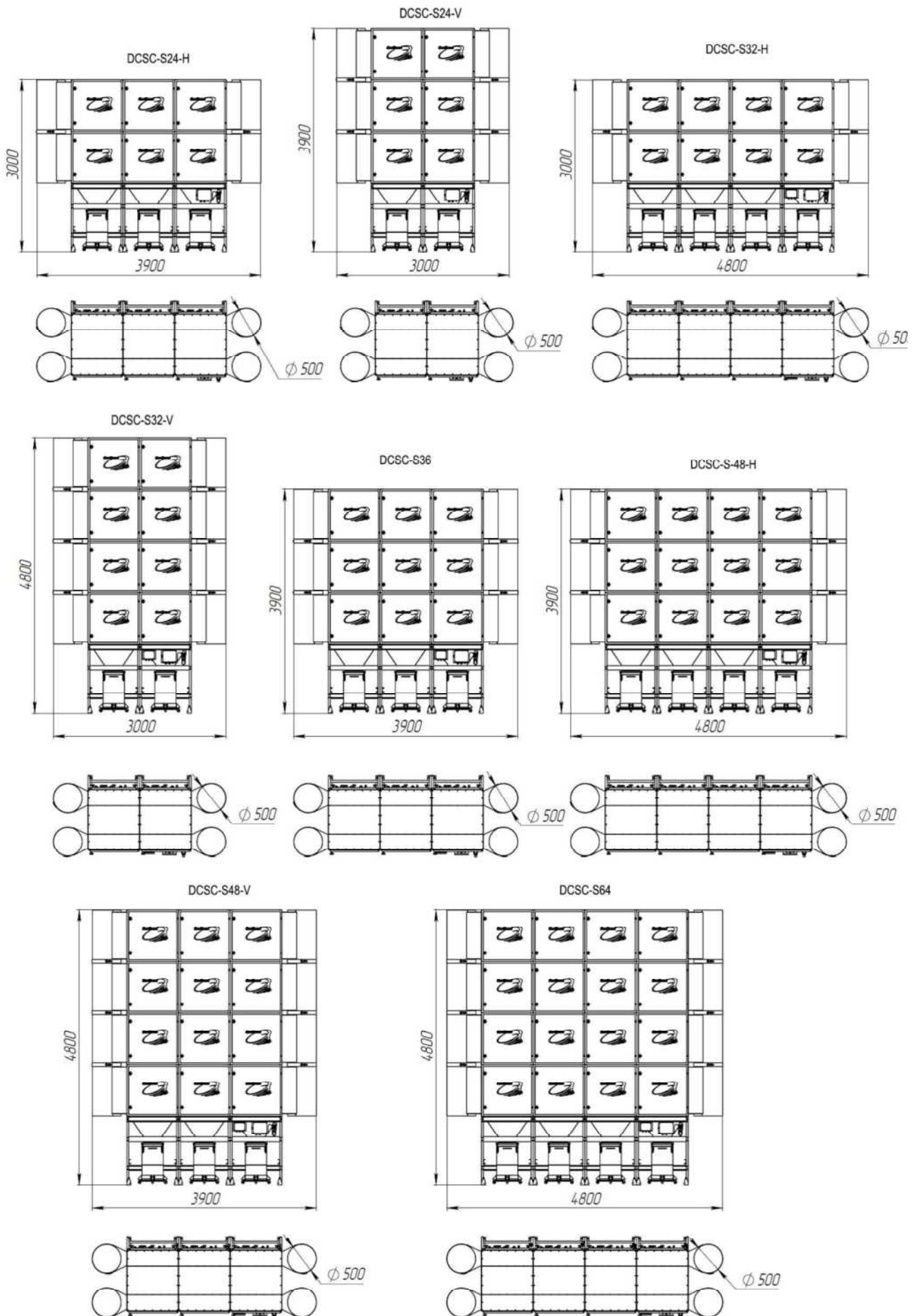

MDV | SELF-CLEANING FILTER WITH VERTICAL CARTRIDGES



Description

MDV series filters are universal single-module industrial filters with vertical positioning of cartridges and automatic cartridge cleaning system by compressed air.

MDV filters are supplied in one of two optional designs:

- 1) for work inside the heated premises
- 2) for outdoor installation and non-heated premises.

Intended use

MDV filters are special designed for cleaning the air from hazardous substances, allocated during following processes:

- welding;
- thermal cutting of metals (plasma, laser, gas);
- sand- and shot-blasting;
- dry cutting, grinding, polishing of metals;
- processing of plastics and composite materials;
- powder coating;
- work with bulk materials;
- other processes with formation of dry, non-sticky and non-explosive dust.

Limitations

Surrounding environment and cleaned air should not be explosive and/or containing any aggressive vapors or gases, particles inclined to smoldering or self-ignition.



Features and advantages

- MDV-4 allows saving space in work area due to compact body dimensions 1100x1106mm (without control box and oil-moisture separator);
- Vertical positioning of retractable cartridges with special air splitting insert ensures high cartridge cleaning efficiency by compressed air;
- Replacing and maintenance of cartridges is very simple do to original cartridge fixing system, which allows easy and fast extraction of cartridges without any special preparation or tools;
- Air splitting insert easily reinstalled into new cartridge;
- Models without fan have single module design and are being supplied preassembled, simplifying and decreasing costs for transportation and installation;
- Height of units allows transportation in standard trucks and containers;
- Filters can be moved and loaded with crane or forklift;
- All units have large dust bin of 120 liters on coasters with convenient system for manual fixing without using of compressed air;
- Models with integrated fan are dispatched in two modules, which can be easily connected on site without any help from manufacturer;
- Integrated fan is fully covered with noise reduction jacket and has air discharge opening upwards, avoiding air drafts in work zone and lifting dust from the floor;
- Integrated metal screen and optional mesh pre-filter, made of stainless steel, highly efficiently protect cartridges from coarse dust particles;
- New control box with ΔP -function, which starts cartridge cleaning system at estimated pressure drop, decreases consumption of compressed air and prolongs cartridges service life;
- Control box has display, showing settings menu during setup regime and cartridge clogging level (current pressure drop in Pa) during working regime;
- Automatic cartridge cleaning system works at running fan, and after fan is switched off it starts final cleaning cycle, ensuring constant minimal resistance of cartridges and long lifetime;
- Models with integrated fan are equipped with control box, having starter with thermal relay, LED and sound indication of critical cartridge clogging level;
- Control box can be installed either on the left or right side of the filter;
- For convenient connection of ducting there are two optional types of connection ducts: straight and angled.

General technical characteristics

Name of the parameter or characteristic	Parameter value
Maximum inlet dust concentration, g/m ³	≤ 2
Filtration class DIN EN 779-93	F9
Filtration class DIN EN 60335-2-69	M
Compressed air consumption, n.m ³ /h	300
Compressed air pressure (working), MPa (bar)	0,5-0,55 (5,0-5,5)
Compressed air cleanliness class	9
Filter power supply voltage, V/Hz/Ph	400/50/3
Filter power consumptions without fan power consideration, W	100
Electromagnetic valve power supply voltage, V	~24
Temperature of cleaned air flow, °C	до 80
Dustbin capacity, liters	120

Production range of filters

(models without integrated fan)



Technical characteristics of filters without fan

Parameter	Model*	MDV-4L-XXX	MDV-6L-XXX	MDV-8L-XXX	MDV-10L-XXX	MDV-12L-XXX	MDV-18L-XXX
		MDV-4R-XXX	MDV-6R-XXX	MDV-8R-XXX	MDV-10R-XXX	MDV-12R-XXX	MDV-18R-XXX
Maximum airflow, cmh		8 000	12 000	16 000	20 000	24 000	36 000
Number of cartridges, pcs		4	6	8	10	12	18
Filtration surface area, m ²		80	120	160	200	240	360
Maximum weight, kg		560	560	560	560	560	560
Initial concentration, g/m ³		2					
Control box power supply voltage, V		220 V					
Control box power, W		100					
Control of filtration cartridge condition		Visual on LCD display, according to digital differential manometer data					
Type of filtration cartridge (index in model (XXX))		CART-VL-T20 polyester with PTFE-membrane CART-VL-TC20 polyester with PTFE membrane and antistatic coating CART-VL-D20 polyester (pre-coating is recommended 1kg per 1 cartridge) CART-VL-C20 polyester with antistatic coating (pre-coating is recommended 1kg per 1 cartridge)					
Filtration class		F9					
Number of dust bins (volume, liters)		1 (120)	1 (120)	2 (240)	2 (240)	2 (240)	3 (360)
Cleaning method		Compressed air					
Consumption of compressed air (liters of free air)		50 liters per 1 pulse					
Pulse frequency per minute (factory default)		2 pulses/minute – factory default 6 pulses/minute – recommended maximum					
Compressed air pressure, bar		5,5					
Fan		To be chosen and ordered separately					
*Indexes		L – control box on the left side R – control box on the right side XXX – type of the cartridge Sample of model index: MDV-8R-T20, MDV-10R-TC20					

Technical characteristics of filters with fan in noise reduction jacket

Filter model*	Name of the parameter or characteristic						
	Fan power, kW	Airflow, cmh	Active filtration surface area, m ²	Filtration material index for CART-VL cartridge	Notes	Max. pressure drop ΔP , Pa	Max. weight, kg
MDV-4L-F7-T20	5,5	3500 – 6500	80 (4 cartridges)	T	Pre-coating not required	1800	750
MDV-4L-F7-TC20				TC			
MDV-4L-F7-D20				D	Pre-coating recommended. 1kg per 1 cartridge.	1500	
MDV-4L-F7-C20							
MDV-4R-F7-T20				T	Pre-coating not required	1800	
MDV-4R-F7-TC20				TC			
MDV-4R-F7-D20				D	Pre-coating recommended. 1kg per 1 cartridge.	1500	
MDV-4R-F7-C20							
MDV-6L-F9-T20	7,5	4000 – 9000	120 (6 cartridges)	T	Pre-coating not required	1800	960
MDV-6L-F9-TC20				TC			
MDV-6L-F9-D20				D	Pre-coating recommended. 1kg per 1 cartridge.	1500	
MDV-6L-F9-C20							
MDV-6L-F11-T20	11	4000 – 10500	120 (6 cartridges)	T	Pre-coating not required	1800	960
MDV-6L-F11-TC20				TC			
MDV-6L-F11-D20				D	Pre-coating recommended. 1kg per 1 cartridge.	1500	
MDV-6L-F11-C20							
MDV-6R-F9-T20	7,5	4000 – 9000	120 (6 cartridges)	T	Pre-coating not required	1800	960
MDV-6R-F9-TC20				TC			
MDV-6R-F9-D20				D	Pre-coating recommended. 1kg per 1 cartridge.	1500	
MDV-6R-F9-C20							
MDV-6R-F11-T20	11	4000 – 10500	120 (6 cartridges)	T	Pre-coating not required	1800	980
MDV-6R-F11-TC20				TC			
MDV-6R-F11-D20				D	Pre-coating recommended. 1kg per 1 cartridge.	1500	
MDV-6R-F11-C20							

* Indications: L – control box on the left; R – control box on the right

Additional components

Connection duct

Connection duct is used for connection of the filter to the ducting of ventilation system. It is being installed at the inlet and outlet of the filter. Duct dimensions are being chosen depending on the ventilation system ducts. Connection duct can be straight or angled, having diameter of 315, 400 or 500mm.

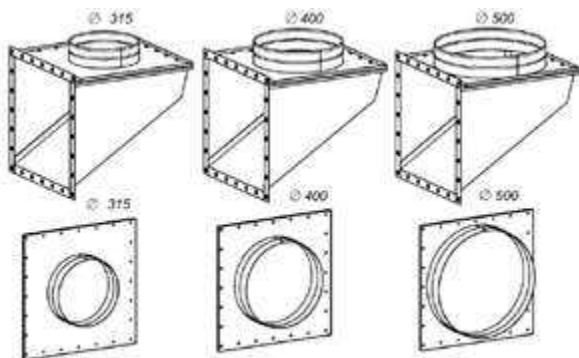

Types of connection ducts.

Pre-filter module

Pre-filter module – preliminary filtration module for capturing of coarse particles, shavings, slag and other pollutants, which can damage filtration cartridge when hitting it. Module is installed on the 500x500 flange of the inlet of MDV, before required connection duct DC-MDV-X-XXX. Design of pre-filter allows extraction of mesh net pre-filter block, made of stainless steel, for cleaning or replacement.

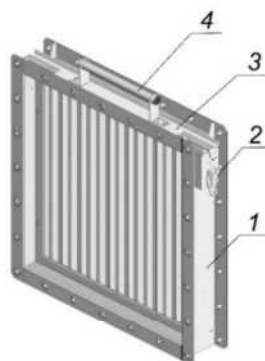

1. Block body;
2. Pre-filter fixing lock;
3. Pre-filter;
4. Pre-filter handle.

Dimensions and connection so filter models without integrated fan

MDV-4L (for MDV-4R, positioning of OMS and controller is opposite)

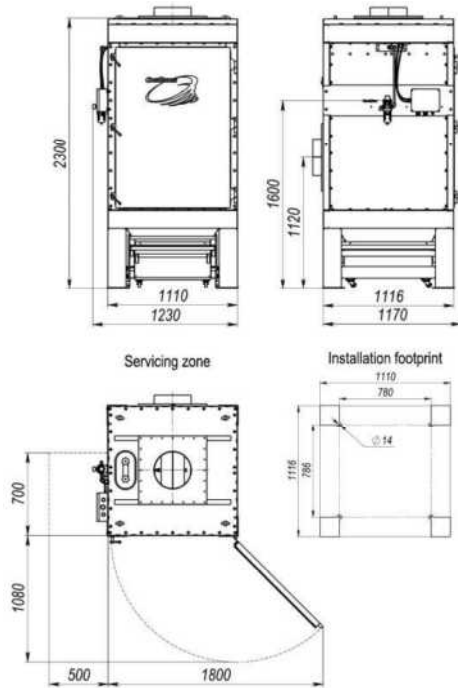

MDV-6L (for MDV-6R, positioning of OMS and controller is opposite)

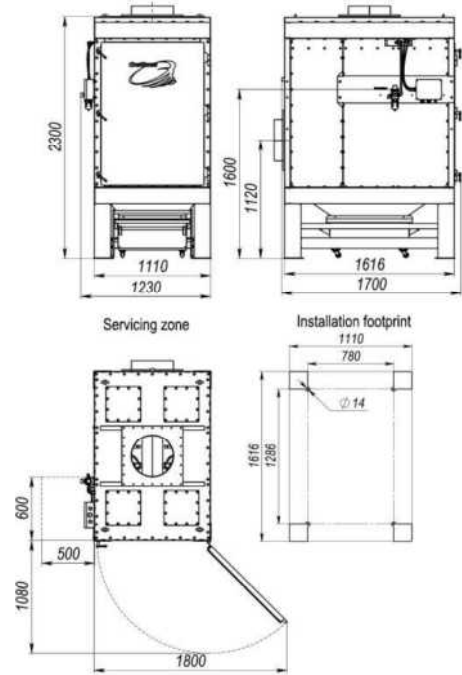

MDV-8L (for MDV-8R, positioning of OMS and controller is opposite)

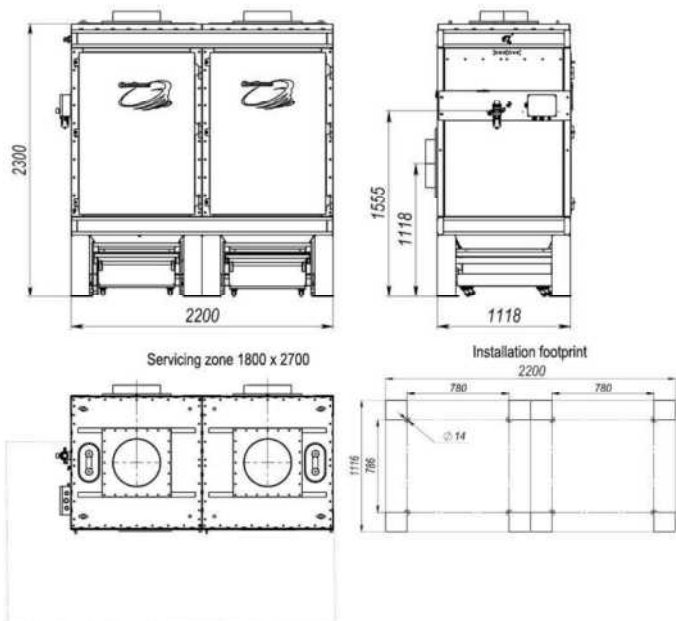

MDV-10L, MDV-12L (for MDV-10R, MDV-12R positioning of OMS and controller is opposite)

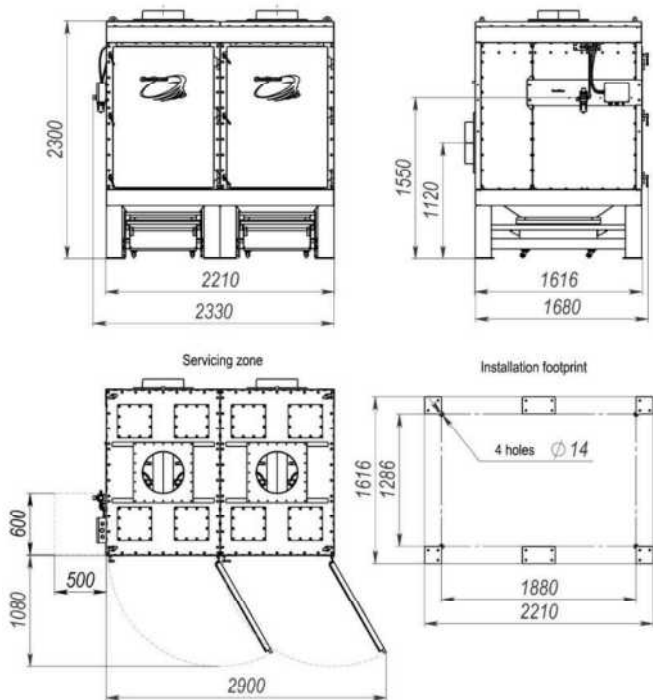

MDV-10L, MDV-12L (for MDV-10R, MDV-12R positioning of OMS and controller is opposite)

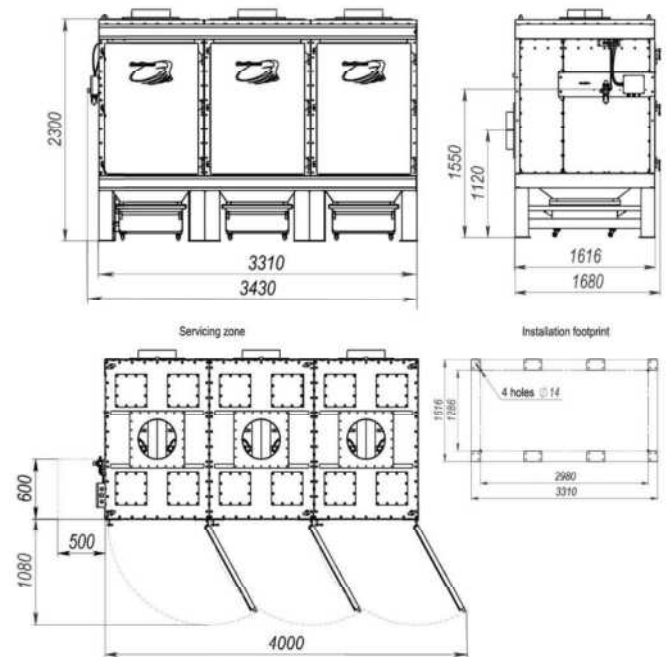

Dimensions and connection so filter models with integrated fan in noise reduction jacket

MDV-4L-F (for MDV-4R-F, positioning of OMS and controller is opposite)

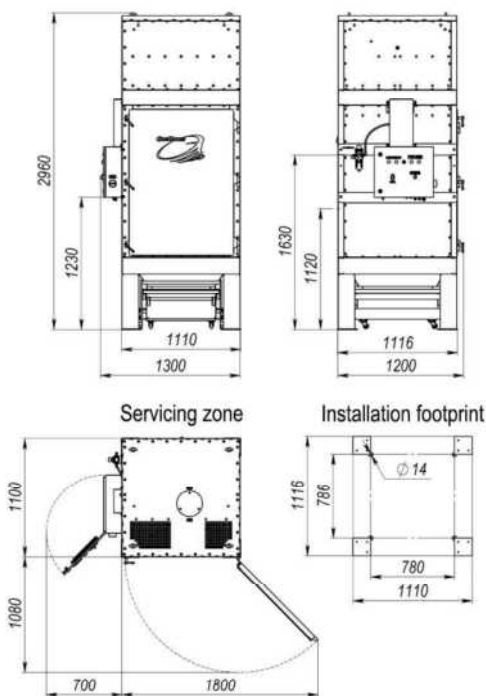

MDV-6L-F (for MDV-6R-F, positioning of OMS and controller is opposite)

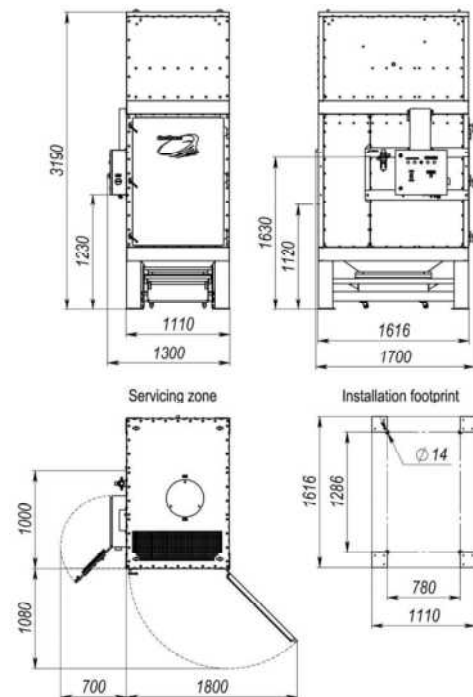

Push-Pull

VENTILATION SYSTEM

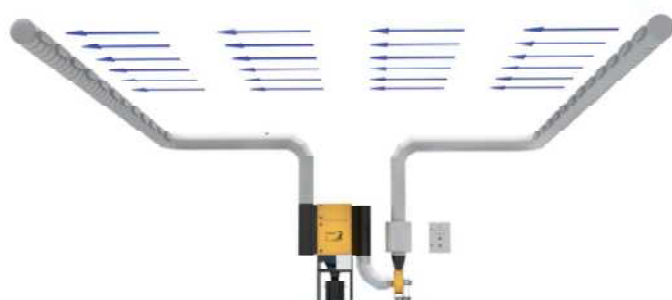
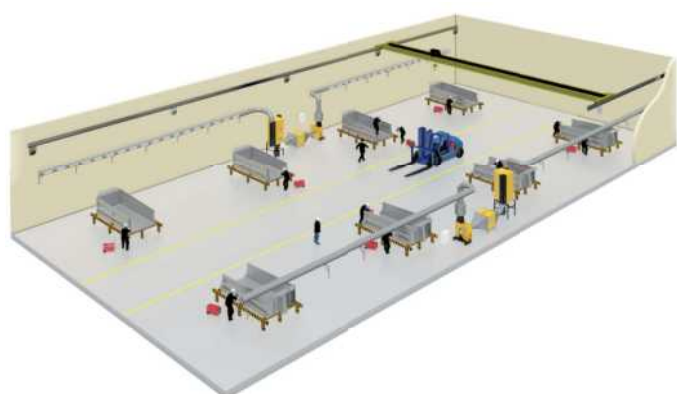

Description

Push-Pull system is a technical solution, based on the principle of organized recirculation of air at certain parts of workshop, or in the entire workshop. This system provides forced displacement of welding fume cloud by directional air stream, capturing of the fume, filtration and returning of cleaned air back into the premises according to specially designed, calculated and set up algorithm.

Push-Pulls systems prevent accumulation of welding fume and decrease background concentration of pollutants in the working zone and in entire volume of industrial premises.

Push-Pull systems are individual solutions, considering special features of industrial process, equipment placement, types of manufactured parts, special features of the building where the workshop is organized.

Intended use

Push-Pull systems are specially designed for solving the problems of ventilation and cleaning of air in the workshops of industrial factories, where welding of large scale constructions take place, making usage of local extraction devices very complicated or impossible.



Major technical parameters

Name	Value
Max. width of the system (workshop)	24 m
Min. width of the system	5 m
Max. length of the system	50 m
Min. length of the system	m m
Height of duct installation	4 to 6 m
Optimal duct diameter	Ø400, Ø500 mm
Max. airflow per single filter	up to 10 000 m ³ /h
Airflow per one grid	250 to 1300 cmh (depending on system width)

Working principle

When developing the Push-Pull systems, physical properties of welding fumes were considered, according to which, welding aerosols rise up to the height of 4-6 meters and form the cloud, which can be easily seen.

In order to eliminate this cloud, we developed a filtration system, having two lines of ducts, installed on the opposite walls of the workshop at the height of cloud formation. One duct has push grids BG-1300 installed in it, and other one has pull grids SG-1300, in order to create laminar airflow across the workshop. In between push and pull lines of the ventilation system, modular self-cleaning filter of DCSC-S series is being installed together with fan in noise reduction jacket and optional silencer.

When additional cleaning of air from gases and smells is required, special MIF filter for gaseous components is being installed after self-cleaning dust collector.

Depending on the required airflow and special features of the premises, Push-Pull systems can have different configuration and be supplied with filters or required capacity. Work of the filtration system is being controlled with the special control box CONT-PP.

Depending on the volume of the premises, distance between walls, type of welding and consumption of welding electrodes or wire, type of welded metals and other parameters, SovPlym engineers do the required calculations to determine filter capacity, length of ducts, number of grids and other parameters of the system.

Diluter

VENTILATION
SYSTEM



Description

Diluter system, same as Push-Pull system, is a technical solution, based on the principle of organized recirculation of air at localized parts or entire workshop. Welding fume's cloud is forced to move by directed streams of air with the purpose of capturing, filtration and bringing clean air back to premises, with the help of specially calculated and set up ventilation and filtration system.

One of the major differences of Diluter from Push-Pull system is reach distance of airflow streams. Diluter systems are intended for servicing the premises up to 50m wide, while Push-Pull systems can be used only up to 24m.

Diluter systems prevent accumulation of welding fume and decrease background concentration of pollutants in the total volume of industrial workshop. Diluter systems are an individual solution, considering special features of industrial process, placement of equipment, parameters of the building, where workshop is located.

Intended use

Diluter systems are developed for solving the problems with ventilation and air cleaning in workshops of various industrial factories, with width of workshops up to 50m, where welding of large scale structures or very long items takes place and usage of local extraction systems is complicated or impossible.



Special features of Diluter systems

- Developed for workshops up to 50m wide
- Does not require installation of ducting
- Easily movable from one location to another
- Single frame installation for easy transportation
- Supplied with integrated control box with frequency inverter.

Technical characteristics

Name	Value
Maximum productivity of the system	9000 cmh
Total number of nozzles	6 pcs
Max. airflow through one nozzle (reach distance – 50m)	1500 cmh
Max. airflow through one nozzle (reach distance – 20m)	1000 cmh
Fan power	11 kW, 3 ph, 50 Hz
Filtration surface area of self-cleaning dust collector DCSC-S-10V-T12	120 m ²
Number of cartridges	10 pcs
Cartridge material	PTFE membrane
Filtration class	F9, M (DIN EN 60335)
Compressed air pressure for automatic cleaning system	5,5 atm
Max. consumption of compressed air per one installation (pulse frequency: 1 pulse per minute)	50 l/min of free air
Weight of the system	690 kg
Noise level	< 75 dB

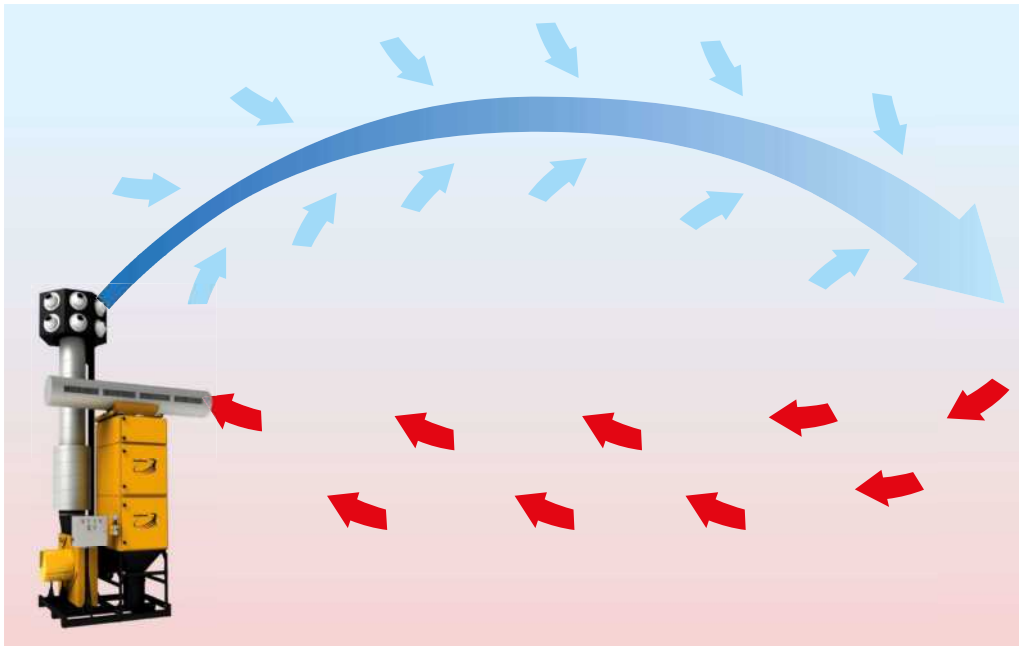

Working principle

When developing the Diluter systems, physical properties of welding fumes were considered, according to which, welding aerosols rise up to the height of 4-6 meters and form the cloud, which can be easily seen.

In order to eliminate welding fumes, special ventilation system was developed with special air supply system, having long range nozzles up to 50m.

Standard nozzles of air supply system have 160mm diameter, supplying up to 1500cmh of air each. Depending on the size of the premises, length of the air stream can be reduced or increased with special integrated damper. Length of the stream and productivity can be adjusted by installation of nozzles with different diameter or changing the fan productivity with frequency inverter, integrated in the control box.

Nozzles of the air supply device can be rotated in any direction, allowing organization of efficient displacement of welding fumes from breathing zone of workers towards suction part of Diluter installation.

One of the ways of airflow organization is shown on the picture above.

Diluter systems are supplied with modern highly efficient self-cleaning filters, integrated control box with frequency inverter and rotary knob for manual adjustment of rpms and fan productivity.

Calculation of number of Diluter systems required, places of their installation, settings for direction and speed of air streams are done by specialists of JSC SovPlym with consideration of volume of premises, width of workshops, type of welding, consumption of welding wire (electrodes), types of welded metals and some other parameters.

Appearance of air supply system



Basic design sketch of the Diluter system

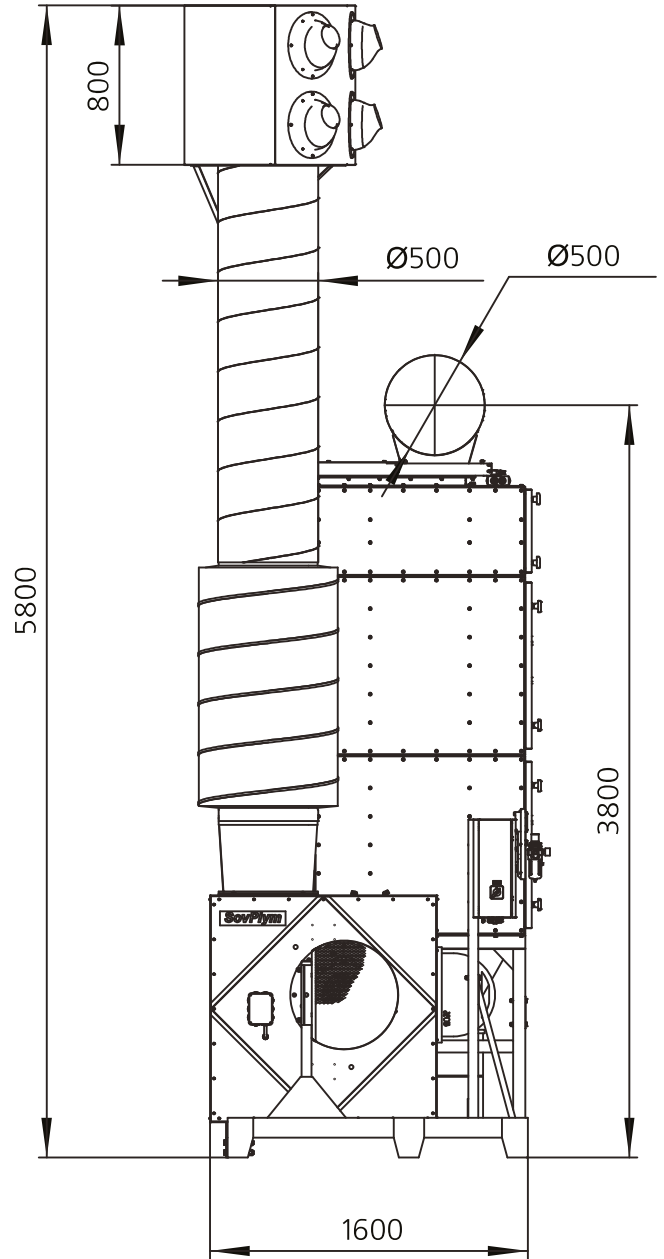
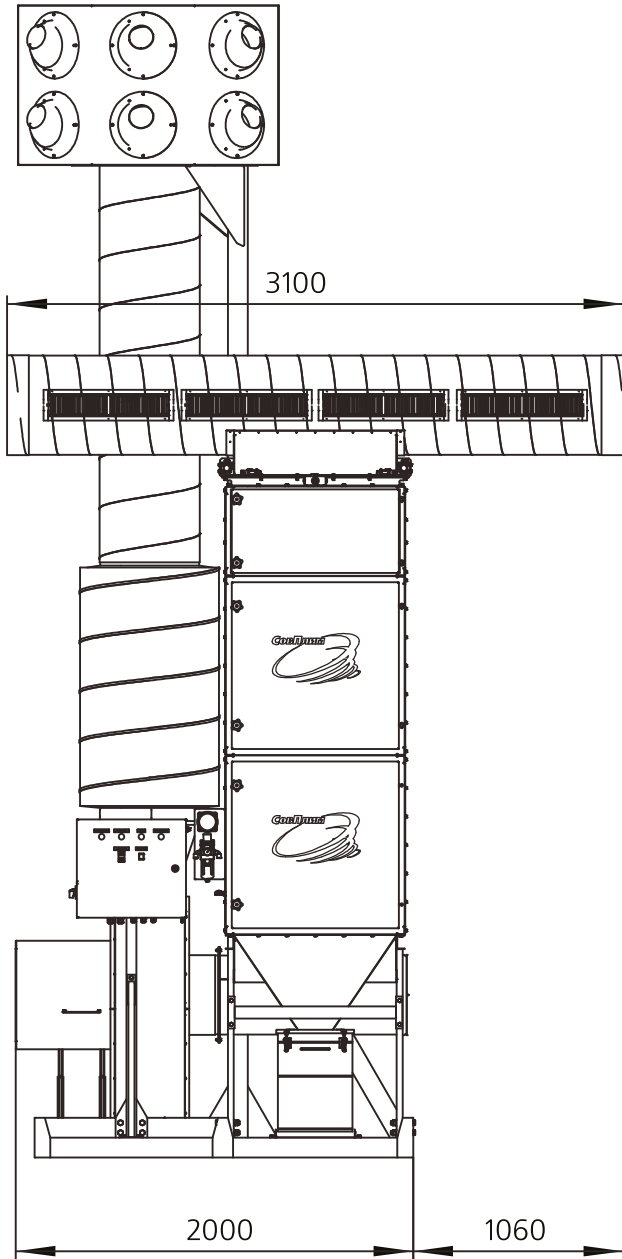

DCA-3X / DCA-4X | STATIONARY MECHANICAL ACCUMULATIVE FILTERS



Description

DCA-31, DCA-32, DCA-41 and DCA-42 filters are mechanical stationary filters with replaceable accumulative cartridges. These filters are being used as a part of ventilation system at various industrial factories, repair workshops and training classes.

Single DCA-XX filters consist of one vertical block of chambers, mounted over on-floor inlet chamber with two Ø250mm inlets on both sides and adjustable supports. Design of single filters allow installation of extraction fan both directly on top of the filter and next to filtration module.

Each filter has two or three chambers with replaceable filters, each offering certain cleaning degree. Door of each chamber has differential manometer installed.

Intended use

- Soldering
- Tinning
- Laser marking and engraving
- Contact welding
- Other types of similar fumes

Limitations

Surrounding environment and cleaned air should not be explosive and/or containing any aggressive vapors or gases, particles inclined to smoldering or self-ignition.



Features and advantages

- Wide range of applicable industrial processes from soldering to laser engraving;
- Optional combinations of cleaning stages depending on the industrial process;
- Filter has standards sets for 4 cleaning stages
 - mesh pre-filter of stainless steel (washable)
 - fine filter (F9 filtration class)
 - highly efficient HEPA filter (F13 filtration class)
 - activated carbon filter (M5 filtration class)
- Convenient control of cartridge clogging due to integrated differential manometers for each stage of cleaning;
- Increased life time of replaceable filters due to increased filtration surface area;
- Simple installation and maintenance, requiring no special training;
- Low cost of units and spare components.

Climate requirements

Characteristics	Value
Minimum operating temperature	5°C
Normal working temperature	20°C
Maximum working temperature	45°C
Maximum relative humidity at 20°C	80%
Temperature of processed airflow, max	80°C

Technical characteristics

(see page 85)

Filtration stages

Stage of filtration	Class of filtration	Filter model	Filtration stages in the filter			
			DCA-31 DCA-31/2 DCA-31/3	DCA-32 DCA-32/2 DCA-32/3	DCA-41 DCA-41/2 DCA-41/3	DCA-42 DCA-42/2 DCA-42/3
Pre-filter	G3	ME-INL/PF	X	X	X	X
Fine filter	F9	MK-004	X	X	X	X
Highly efficient HEPA filter	H13	HFME-3		X		X
Activated carbon filter	M5	CF-003			X	X



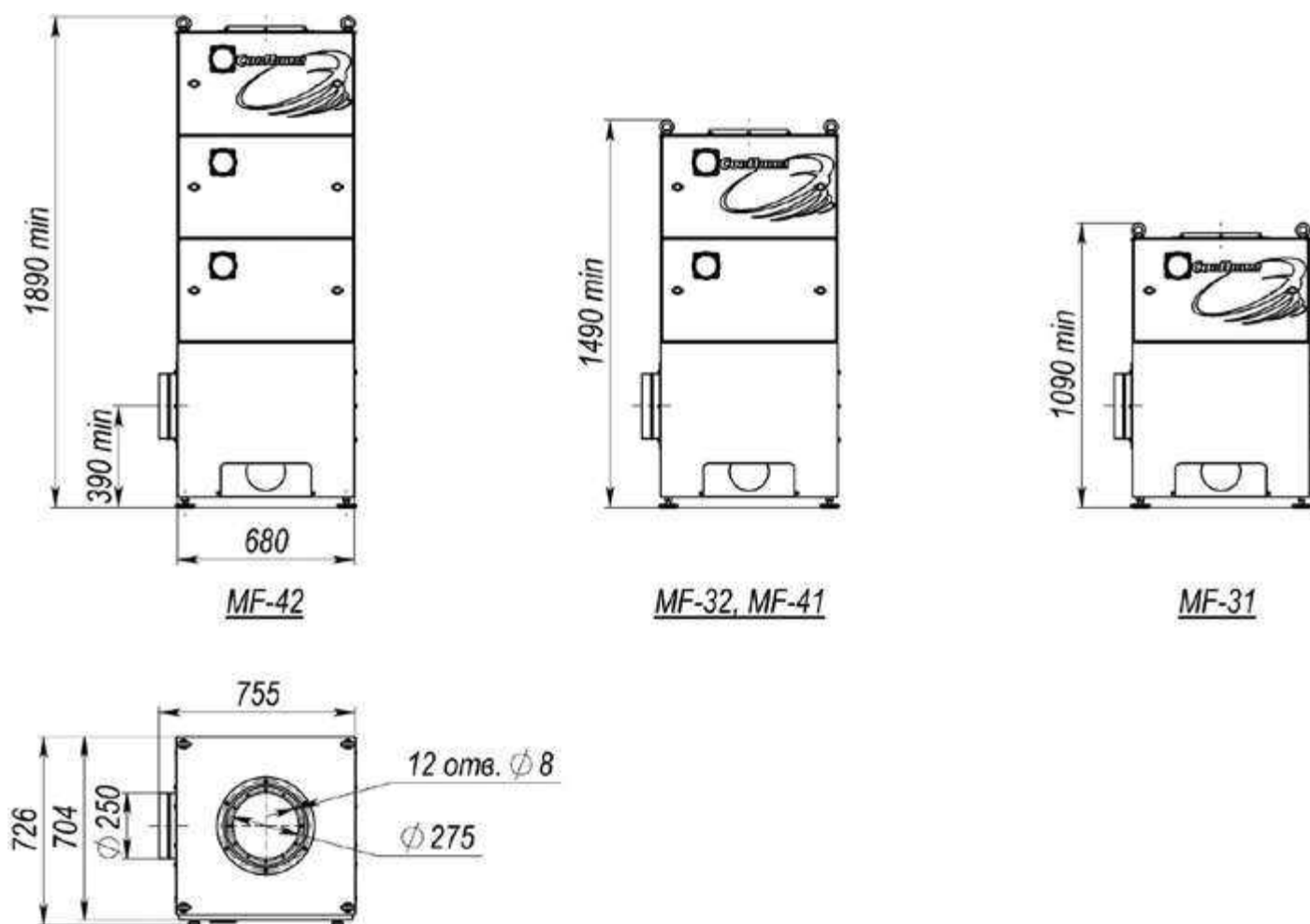

Working principle

- First filtration stage separates coarse dust particles. This process takes place in the inlet chamber due to widening of airflow and decrease of its speed.
- Then, rest of coarse particles and medium particles are being stopped in the pre-filter ME-INL/PF (G3 filtration class).
- Small particles with size down to 0,2 micron are being stopped by main fine filter MK-004 (F9 filtration class).
- Remaining fine particles are being stopped by the highly efficient HEPA filter (H13 filtration class). Models with HEPA filters should be used in situations, when clean air should be returned back into premises.
- After that, toxic gaseous compounds and unpleasant odors, formed, for example, during soldering and similar operations, accompanied by significant heating of various substances, are being captured by activated carbon filter CF-003, which is being used as final filtration stage.



Dimensions and connections



Production range

Drawing	Article	Model	Description and delivery scope
	27614	DCA-31	Max. airflow 2500 m ³ /h. Inlet and outlet Ø: 250/250mm. Delivery scope: pre-filter ME-INL-PF – 1pcs., fine filter MK-004 – 1pcs, inlet Ø250mm, transition piece for connection of the fan Ø250mm FF-FAN-B. To be ordered separately: fan, starter or freq.drive.
	27617	DCA-32	Max. airflow 2500 m ³ /h. Inlet and outlet Ø: 250/250mm. Delivery scope: pre-filter ME-INL-PF – 1pcs., fine filter MK-004 – 1pcs, HEPA filter HFME-3 – 1pcs, inlet Ø250mm, transition piece for connection of the fan Ø250mm FF-FAN-B. To be ordered separately: fan, starter or freq.drive.
	27620	DCA-41	Max. airflow 2500 m ³ /h. Inlet and outlet Ø: 250/250mm. Delivery scope: pre-filter ME-INL-PF – 1pcs., fine filter MK-004 – 1pcs, activated carbon filter CF-003, inlet Ø250mm, transition piece for connection of the fan Ø250mm FF-FAN-B. To be ordered separately: fan, starter or freq.drive.
	27623	DCA-42	Max. airflow 2500 m ³ /h. Inlet and outlet Ø: 250/250mm. Delivery scope: pre-filter ME-INL-PF – 1pcs., fine filter MK-004 – 1pcs, HEPA filter HFME-3 – 1pcs, activated carbon filter CF-003, inlet Ø250mm, transition piece for connection of the fan Ø250mm FF-FAN-B. To be ordered separately: fan, starter or freq.drive.

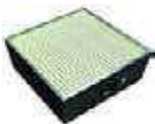
Spares and accessories

Drawing	Article	Model	Description
	6084	ME-INL/PF	Pre-filter. Mesh filter of stainless steel. Washable. Included in standard delivery set for all DCA filters.
	131868	MK-004	Fine filter with F9 filtration class, 610x610x292mm, 25m ² . Material: fiberglass. For DCA-31/32/41/42 filters. Main filter. Included in standard delivery set for all models. Recommended replacement, when reaching pressure drop of 800 Pa.
	98803	HFME-3	Highly efficient HEPA H13 filter, 610x610x292, 25m ² . Filtration class H13. Recommended replacement, when reaching pressure drop of 800 Pa.
	131869	CF-003	Activated carbon filter. For DCA-41 and DCA-42 filters. Recommended replacement, when reaching pressure drop of 500 Pa.

Not included in the delivery set:

- extraction fan;
- starter with thermal relay or freq.drive;
- silencer, ducts and accessories.

DCA-3X/X /DCA-4X/X

STATIONARY MECHANICAL FILTERS
MODULAR SERIES



Description

DCA-3X/X and DCA-4X/X units are stationary mechanical filters of modular type. Main difference from DCA-3X and DCA-4X is that, due to modular design, they can provide required airflow in a wide range: from 5000 to 12500 cmh. Filters are being used as a part of ventilation system at various industrial factories, repair workshops and training facilities.

Modular DCA-XX/X filters consist of two or three vertical blocks of chambers, mounted on the common basis, being an on floor inlet with two Ø500mm inlets on both sides and adjustable supports. Fan should be mounted separately next to the filter and connected to the filter with a corresponding ducting set.

Each module has one, two or three chambers with preinstalled replaceable filters of different grade. Each chamber has differential manometer.

Intended use

- Soldering
- Tinning
- Laser marking and engraving
- Contact welding
- Other types of similar fumes

Limitations

Surrounding environment and cleaned air should not be explosive and/or containing any aggressive vapors or gases, particles inclined to smoldering or self-ignition.



Features and advantages

- Wide range of applicable industrial processes from soldering to laser engraving;
- Modular design allows building a filter with wide range of productivity from 5000 to 12500 m³/h;
- Optional combinations of cleaning stages depending on the industrial process;
- Filter has standards sets for 4 cleaning stages
 - mesh pre-filter of stainless steel (washable)
 - fine filter (F9 filtration class)
 - highly efficient HEPA filter (F13 filtration class)
 - activated carbon filter (M5 filtration class)
- Optional combination of several modules in order to reach total airflow over 12500 m³/h;
- Convenient control of cartridge clogging due to integrated differential manometers for each stage of cleaning;
- Increased life time of replaceable filters due to increased filtration surface area;
- Simple installation and maintenance, requiring no special training;
- Low cost of units and spare components.

Climate requirements

Characteristics	Value
Minimum operating temperature	5°C
Normal working temperature	20°C
Maximum working temperature	45°C
Maximum relative humidity at 20°C	80%
Temperature of processed airflow, max	80°C

Spares and accessories

(see page 83)

Technical characteristics

Article	Model	Max. airflow, cmh	Pressure drop, Pa	Max. negative pressure, Pa	Dimensions, LxWxH, mm	Weight, kg
27614	MF-31	2500	1300	4000	680 x 726 x 1090	88
27615	MF-31/2	5000	1300	4000	1390 x 726 x 1360	195
27616	MF-31/3	7500	1300	4000	2085 x 726 x 1360	278
27617	MF-32	2500	1500	4000	680 x 726 x 1490	134
27618	MF-32/2	5000	1500	4000	1390 x 726 x 1755	271
27619	MF-32/3	7500	1500	4000	2085 x 726 x 1755	392
27620	MF-41	2500	1300	4000	680 x 726 x 1490	134
27621	MF-41/2	5000	1300	4000	1390 x 726 x 1755	271
27622	MF-41/3	7500	1300	4000	2085 x 726 x 1755	392
27623	MF-42	2500	1800	4000	680 x 726 x 1890	175
27624	MF-42/2	5000	1800	4000	1390 x 726 x 2150	353
27625	MF-42/3	7500	1800	4000	2085 x 726 x 2150	515

Filtration stages and classes

(see page 82)

Working principles

(see page 82)

Dimensions and connections

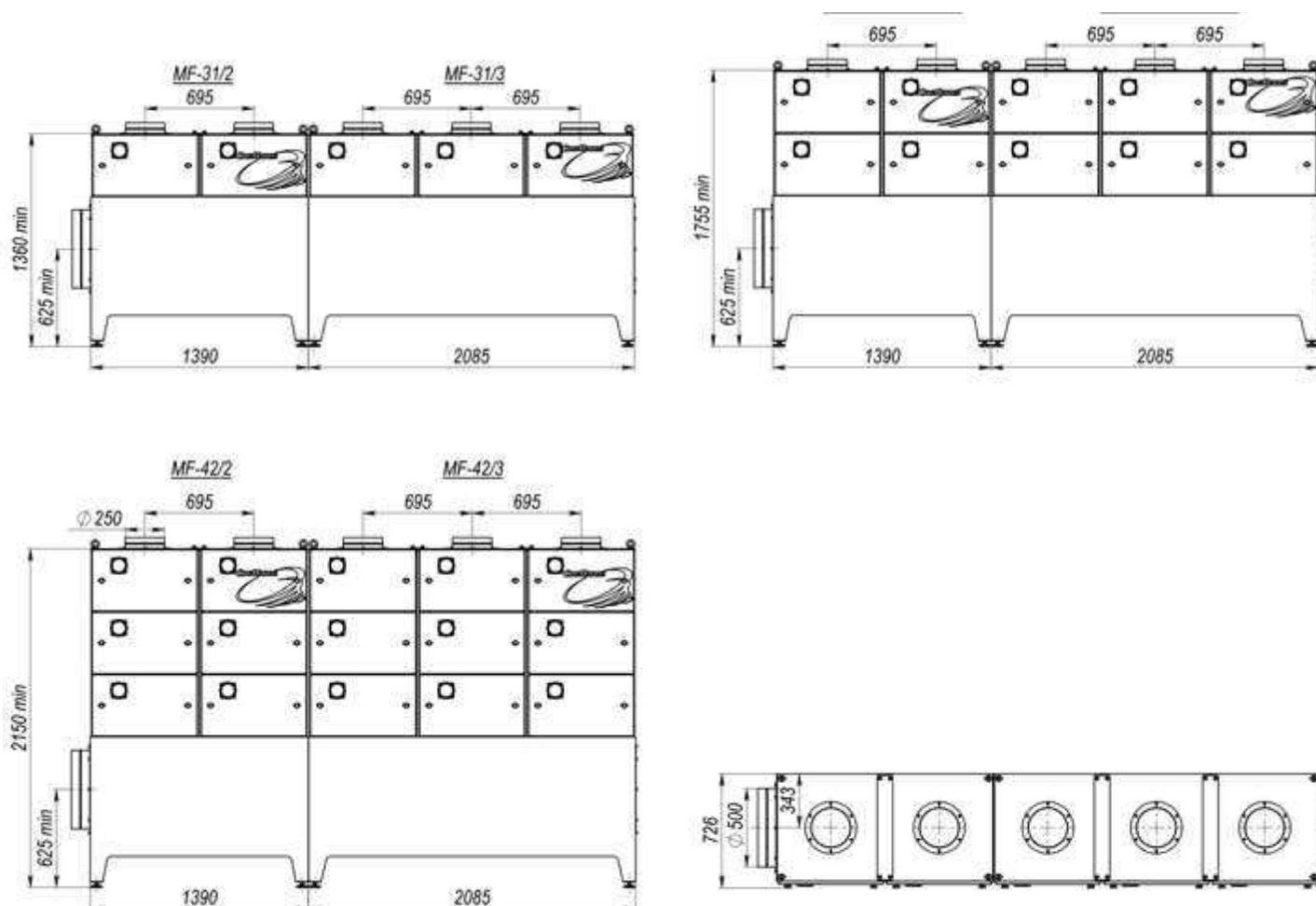

Production range

Drawing	Article	Model	Description and delivery scope
	27615	DCA-31/2	Max. airflow 5000 m ³ /h. Inlet and outlet Ø: 500/2x250mm. Delivery scope: pre-filter ME-INL-PF – 2pcs., fine filter MK-004 – 2pcs. To be ordered separately: fan, outlet MT-OUTLET/XX.
	27616	DCA-31/3	Max. airflow 7500 m ³ /h. Inlet and outlet Ø: 500/3x250mm. Delivery scope: pre-filter ME-INL-PF – 3pcs., fine filter MK-004 – 3pcs. To be ordered separately: fan, outlet MT-OUTLET/XX.
	27618	DCA-32/2	Max. airflow 5000 m ³ /h. Inlet and outlet Ø: 500/2x250mm. Delivery scope: pre-filter ME-INL-PF – 2pcs., fine filter MK-004 – 2pcs, HEPA filter HFME-3 – 2pcs. To be ordered separately: fan, outlet MT-OUTLET/XX.
	27619	DCA-32/3	Max. airflow 7500 m ³ /h. Inlet and outlet Ø: 500/3x250mm. Delivery scope: pre-filter ME-INL-PF – 3pcs., fine filter MK-004 – 3pcs, HEPA filter HFME-3 – 3pcs. To be ordered separately: fan, outlet MT-OUTLET/XX.
	27621	DCA-41/2	Max. airflow 5000 m ³ /h. Inlet and outlet Ø: 500/2x250mm. Delivery scope: pre-filter ME-INL-PF – 2pcs., fine filter MK-004 – 2pcs, activated carbon filter CF-003 – 2pcs. To be ordered separately: fan, outlet MT-OUTLET/XX.
	27622	DCA-41/3	Max. airflow 7500 m ³ /h. Inlet and outlet Ø: 500/3x250mm. Delivery scope: pre-filter ME-INL-PF – 3pcs., fine filter MK-004 – 3pcs, activated carbon filter CF-003 – 3pcs. To be ordered separately: fan, outlet MT-OUTLET/XX.
	27624	DCA-42/2	Max. airflow 5000 m ³ /h. Inlet and outlet Ø: 500/2x250mm. Delivery scope: pre-filter ME-INL-PF – 2pcs., fine filter MK-004 – 2pcs, HEPA filter HFME-3 – 2pcs, activated carbon filter CF-003 – 2pcs. To be ordered separately: fan, outlet MT-OUTLET/XX.
	27625	DCA-42/3	Max. airflow 7500 m ³ /h. Inlet and outlet Ø: 500/3x250mm. Delivery scope: pre-filter ME-INL-PF – 3pcs., fine filter MK-004 – 3pcs, HEPA filter HFME-3 – 3pcs, activated carbon filter CF-003 – 3pcs. To be ordered separately: fan, outlet MT-OUTLET/XX.

MIF | ION EXCHANGE MODULES



Description

Ion-exchange modules MIF are developed for filtration of gaseous components, formed during processes of welding, thermal cutting, painting, galvanization etc. MIF modules are to be connected to the existing ventilation system. Module is being used as a large stage of filter-ventilation system, after cleaning the air from dust and aerosols.



Intended use

- Various types of welding
- Thermal cutting
- Painting
- Galvanization



Limitations

Can not be used for filtration of any type of dust.

Features and advantages

- Neutralizes following types of harmful gases, formed at various types of welding, plasma cutting and others: HF, HCl, NO₂, N_xO_y, SO_x, NaOH, C_xH_y, H₂S, NH₃.
- Allows usage of air recirculation in extraction systems for wide range of industrial processes.

Technical characteristics

	Article	Model	Description
	5422	MIF-5	Stationary module of ion-exchange filters Airflow: 5 000 cmh Connection flanges dimension: 582x1138mm Delivery set includes: ion-exchange cartridge ICE-3-MIF – 2pcs; 4 adjustable legs.
	5142	MIF-10	Stationary module of ion-exchange filters Airflow: 10 000 cmh Connection flanges dimension: 1102x1138mm Delivery set includes: ion-exchange cartridge ICE-3-MIF – 4pcs; 4 adjustable legs.
	5423	MIF-20	Stationary module of ion-exchange filters Airflow: 20 000 cmh Connection flanges dimension: 1102x2288mm Delivery set includes: ion-exchange cartridge ICE-3-MIF – 8pcs; 4 adjustable legs.

METAL PROCESSING WITH COOLANTS

PROTECT YOUR WORKERS AND EQUIPMENT FROM OIL MIST

Oils and coolants are being widely used in various processes of metal processing. Rather harmless in liquid phase, they become toxic in a form of smoke or mist and, during long-term influence, can cause serious harm to health of workers.

Risk of fire is another serious reason, why it is necessary to control oil concentration in the air. Oil mist is being condensed on the surface of the equipment and constructions, significantly increasing the risk of accidental fire.

Removal and filtration of oil mist is one of the most complicated tasks in industrial ventilation due to chemical properties of coolants.

SovPlym offers most modern solutions for filtration of oil mist, which provide health protection for your workers and decrease additional equipment maintenance expenses.

ADVANTAGE OF SAVINGS

Solutions from SovPlym allow collecting filtered oil and coolant for secondary usage, offering significant saving. Range of solutions include small filters for single CNC machines and stationary modular filters for removal of oil mist from multiple sources.

FOR ANY TASKS AND WORKING CONDITIONS

Oil mist filters from SovPlym can handle any types of oils and coolants irrespective to type of task, temperature regime or working conditions.



MT-31/MT-32

Stationary filter for oil mist, formed from coolants, containing polluted highly viscous oil and various types of dust. For 1-2 shift working regime.

page 90



MT-41/MT-42

Stationary filter for oil mist, formed from coolants, containing clean low viscous oil. For 2-3 shift working regime.

page 91



MT-3X/X (MT-31/X, MT-32/X)

Modular oil mist filters on the basis of MT-31/32. Capacity from 6000 to 15000 cmh.

page 94



MT-4X/X (MT-41/X, MT-42/X)

Modular oil mist filters on the basis of MT-41/42. Capacity from 4000 to 10000 cmh.

page 94



MM

Compact filter for cleaning the air from oil mist with optional mounting directly on the machine.

page 96

MT-31/MT-32

MECHANICAL FILTERS FOR
OIL MIST / SMOKE



Description

MT filters are modular system for cleaning the air from oil smoke/mist. MT-31 should be used for filtration of oil mist. When filtration of both oil mist and smoke is required, MT-32 filter should be used, having additional HEPA-filter. All MT filters are modular and can be organized in systems, suitable for specific requirements (see page 92).

Intended use

- Cutting, drilling, sharpening with various metal processing tools and CNC machines.
- Cold stamping and pressing processes.
- Polishing of metals with coolants.

Limitations

MT-31/MT-32 filters should not be used for:

- Laser cutting of alumina;
- Air-arc cutting of metal;
- Filtration of varnish and lacquer materials;
- Filtration of hot gases (constant temperature over 45 C).



Features and advantages

- Intended for 1-2 shift working regime (for low and medium intensity processes).
- Suitable for processes, where coolant can be polluted with metal dust or chunks of burnt oil.
- Suitable for combined (dry and with coolant) metal processing.
- Suitable for processes with oil, having ignition temperature below 150°C (300°F).
- Suitable for processes with maximum initial concentration of oil 30-40 mg/m³.
- Major filters have clogging indication.
- Fan can be installed directly on the filter.
- Easy and fast replacement of filtration elements.
- Two inlets for alternative connection options.

Technical characteristics see page 91

Delivery scope of all MT-31, MT-32, MT-41 and MT-42 includes:

- Filter body with pre-filters and all filtration elements;
- 250mm inlet connecting duct;
- 250mm cover plate on inlet;
- 250mm outlet connecting duct for fan installation (on top side of the filter);
- Outlet connecting duct for external fan connection (see page 93).

To be ordered separately:

- Starter with corresponding thermal relay
- Silencer

MT-41/MT-42 | MECHANICAL FILTERS FOR OIL MIST / SMOKE



Description

MT filters are modular system for cleaning the air from oil smoke/mist. MT-41 should be used for filtration of oil mist. When filtration of both oil mist and smoke is required, MT-42 filter should be used, having additional HEPA-filter. All MT filters are modular and can be organized in systems, suitable for specific requirements.

Intended use

Perfectly suitable for following processes:

- Cutting, drilling, sharpening with various metal processing tools and CNC machines.
- Cold stamping and pressing processes.
- Hardening of metals with usage of coolants

Limitations

MT-41/MT-42 filters should not be used for following:

- Laser cutting of alumina;
- Air-arc cutting of metal;
- Filtration of varnish and lacquer materials;
- Filtration of hot gases (constant temperature over 45°C).



Features and advantages

- Self-drying filters;
- Intended for everyday work in 2-3 shifts (highly intensive working regimes);
- Suitable for oils with low viscosity, which stay clean and can be reused;
- Suitable for synthetic oils;
- Suitable for capturing of water-oil emulsions;
- Main filters have clogging indication;
- Optional installation of the fan directly on the filter;
- Fast and easy replacement of filtration cartridges;
- Two inlets for alternative options of duct connection.

Technical characteristics

Description	MT-31 art. 5290	MT-32 art. 5239	MT-41 art. 5296	MT-42 art. 5299
Airflow, m ³ /h, max.	3000	3000	2000	2000
Pressure drop (for calculations), Pa	700	1200	1300	1500
Weight, kg	98	134	104	138
Filtration class: DIN EN 779 (F9)/DIN EN 1822 (H13); ASHRAE 52.2 (MERV15/MERV16)	F9/MERV15	H13/MERV16	F9/MERV15	H13/MERV16
Negative pressure (max.), Pa	4000			
Oil collector volume (included), liters	10			
Exhaust pipe diameter (in the inlet chamber), mm	2x250 (1 pipe and 1 connector included)			
Connection flange for duct diameter FF-DUCT/250 (ordered separately), mm	250			
Connection flange for fan diameter FF-FAN (for VMA-3000-4700 fans)	250			
OilContainer volume	10 l/1 pcs.			

Delivery set: page 90

Design and filtration principles

5 stage (MT-32)

5 stage (MT-32) HEPA filter (MT-32)
(Fine cleaning, filtration class HI3 DIN EN 1822)

4 stages (MT-31)

4 stage (MT-31) Bag filter
(main filter, stops small particles of oil; filtration class F9 DIN EN 779; 11,2 m², fiberglass plastic)

3 stage mesh pre-filter
(stops mechanical admixtures)

2 stage labyrinth type filter
(stops large and medium particles of aerosol)

1 stage Inlet duct with sikter for liquid particles and drops

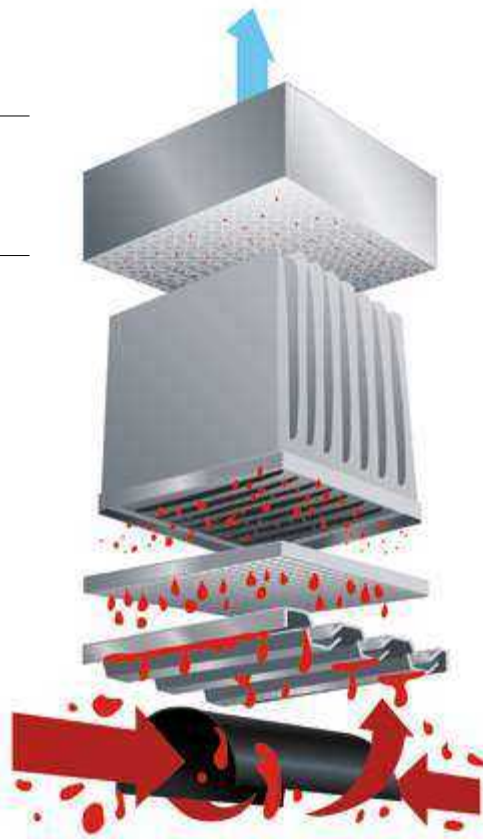

Drain tube for oil

Collected oil can be drained into the collector or returned back into the machine.

5 stage (MT-42)

5 stage (MT-42) HEPA filter (MT-42)
(Fine cleaning, filtration class HI3 DIN EN 1822)

4 stages (MT-41)

4 stage (MT-41) Self-drying cartridge OC-2 (main filter, stops small particles; 24 m², fiberglass, F9 DIN EN 779)

Самоосушаемая кассета OC-1 (main filter, stops medium size particles; 16 m², fiberglass, G4 DIN EN 779)

3 stage mesh pre-filter
(stops mechanical admixtures)

2 stage labyrinth type filter (stops large and medium particles of aerosol)

1 stage Inlet duct with sikter for liquid particles and drops

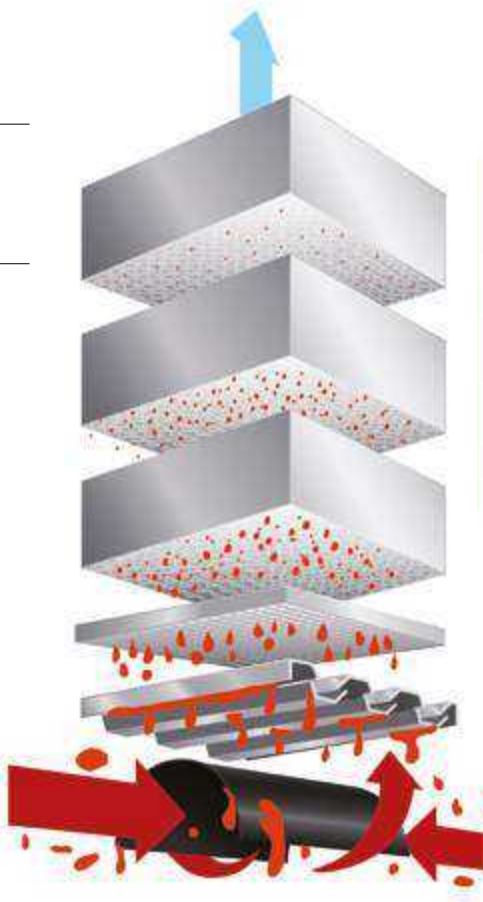

Drain tube for oil

Collected oil can be drained into the collector or returned back into the machine.

Connection options MT-31, MT-32 and MT-41, MT-42

Connection of the fan to the filter

Fan is being installed on the top part of the filter and connected to adapter, which is included in the delivery set.



Connection of filters to external fan

Filter is being connected to 250mm duct with the help of connection flange (ordered separately).



Duct connection to inlet chamber of the filter

Inlet duct is on the right side of the inlet chamber.

As an option, duct can be connected on the left side.

All filters are supplied with 250mm inlet.



MT-3X/X and MT-4X/X

MODULAR FILTERS FOR OIL SMOKE/MIST



MT-31/2
Oil mist

MT-32/5
Oil smoke
Oil mist

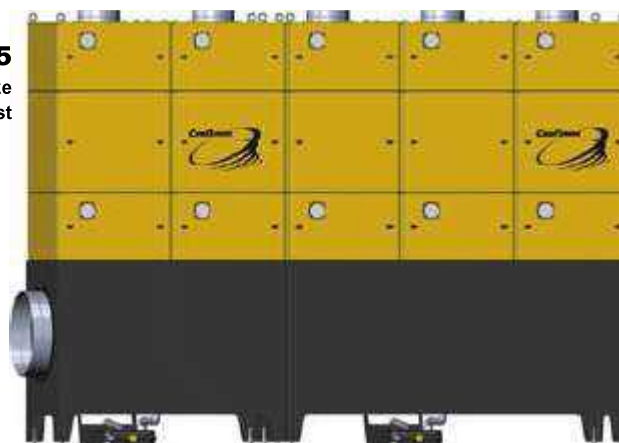

HEPA

Features and advantages

MT filters are modular system, which can be build up considering today's requirements and increased if necessary.

Capacity and efficiency of each module allows fulfilling compact solutions. Technical features and most modern technologies of filtration allow creating the system with lowest maintenance cost. Each filter has clogging indication.



MT-41/2
Oil mist

MT-42/5
Oil smoke
Oil mist

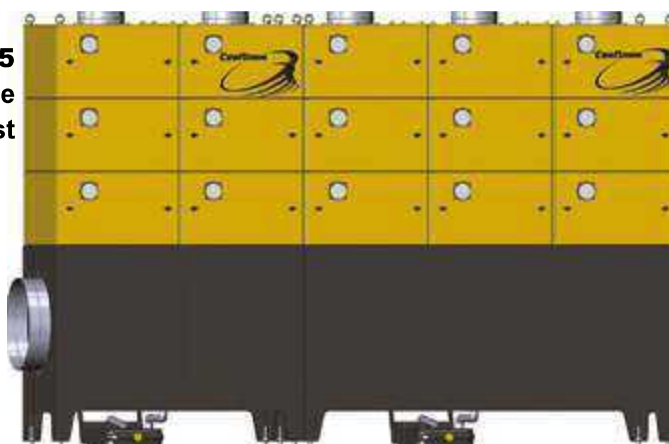





Productivity

MT-31/2, MT-32/2 6 000 m³/h
 MT-31/3, MT-32/3 9 000 m³/h
 MT-31/4, MT-32/4 12 000 m³/h
 MT-31/5, MT-32/5 15 000 m³/h

MT-41/2, MT-42/2 4 000 m³/h
 MT-41/3, MT-42/3 6 000 m³/h
 MT-41/4, MT-42/4 8 000 m³/h
 MT-41/5, MT-42/5 10 000 m³/h

Accessories and spare cartridges

Cartridges are to be replaced when pressure drop exceeds stated below values

	Article	Type of filtration cartridges	Cartridge model	Pressure drop
	37254	Pocket filter	BFME-31	500 Pa
	98801	Self-drying cartridge	OC-1	500 Pa
	98802	Self-drying cartridge	OC-2	800 Pa
	98803	HEPA filter	HFME-3	800 Pa

Connections

Connection of modular filters MT to fans

Two optional types of outlet ducts are available for connection of MT filters to extraction system:

- with side connection;
- with center connection;

	Article	Outlet for connection to the ducting: side connection
	6780	MT-OUTLET/2S for MT-XX/2; Ø400 mm
	6781	MT-OUTLET/3S for MT-XX/3; Ø400 mm
	6782	MT-OUTLET/4S for MT-XX/4; Ø500 mm
	Article	Outlet for connection to the ducting: center connection
	6784	MT-OUTLET/2T for MT-XX/2; Ø400 mm
	6785	MT-OUTLET/3T for MT-XX/3; Ø400 mm
	6786	MT-OUTLET/4T for MT-XX/4; Ø500 mm
6787	MT-OUTLET/5T for MT-XX/5; Ø500 mm	

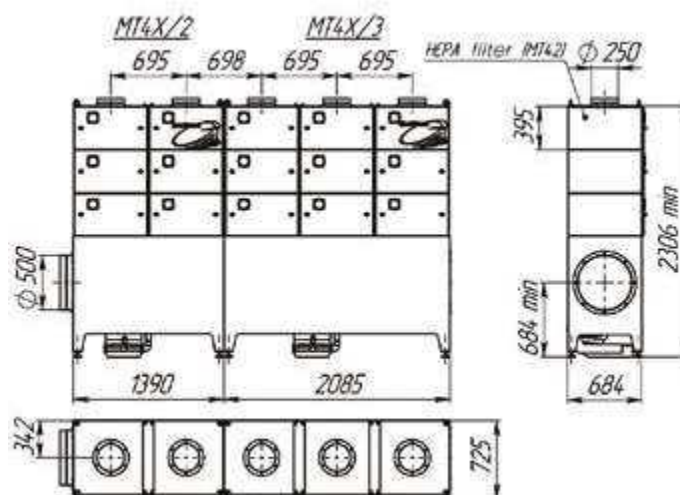
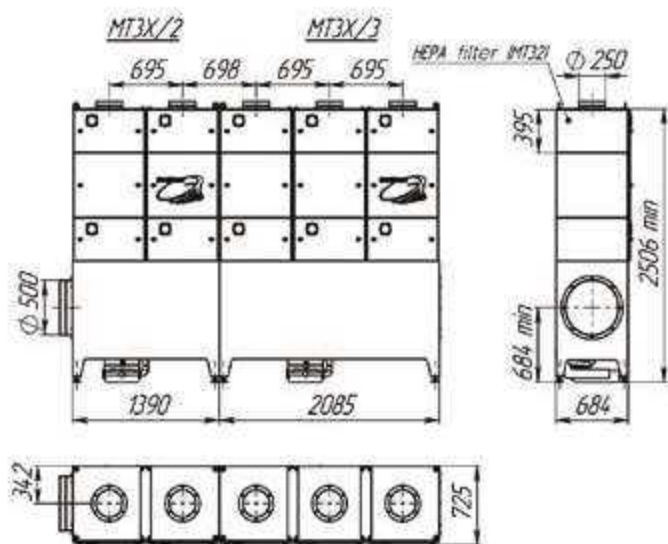

MM | MECHANICAL OIL MIST FILTER



Description

“Mist Magician” filter (MM) is designed for installation directly on the machine without allocation special place for filter installation or ducting installation. MM filter collects oil mist during work process and, if necessary, provides return of collected oil back into the machine. MM filter has number of options for easy and fast installation.

Intended use

MM filters are intended almost for any type of CNC machines, which use coolants on the oil base and produce significant amount of smoke during work process.

Limitations

Not recommended for intense processes with concentrated allocation of smoke.



Features and advantages

- Efficient filtration of oil mist and smoke
- Return of collected oil back into the machine
- Cartridge clogging indication
- Simple replacement of filtration cartridge
- Compact design
- Simple and fast installation
- Low energy consumption
- Low maintenance cost
- Fan installation directly on the filter

Technical characteristics

Article	Productivity, cmh	Filtration surface area, m ²	Cartridge replacement at pressure drop, Pa	Cleaning efficiency class	Inlet diameter, mm	Outlet diameter, mm	Weight, kg
5310	500	10	1000	F9 (DIN EN 779), MERV15 ASHRAE 52.2	160	160	14

Fans recommended for installation on the filter

	Article	Model	Description
	5780	VMA-1100 (recommended)	Radial fan; 150-800 m ³ /h; 1100-400 Pa, 0,37 kW, 380V 50Hz, 3 ph
	5044	VMA-1800	Radial fan; 300-1300 m ³ /h; 1500-700 Pa, 0,55 kW, 380V 50Hz, 3 ph
	5049	VMA-2100	Radial fan; 400-1500 m ³ /h; 1500-650 Pa, 0,75 kW, 380V 50Hz, 3 ph
	6794	MW-FAN-KIT	Fan mounting kit

3-stage cleaning process







Stage 3
Finest particles (less than 1 micron) of the emulsion are being captured by the filter. Clean air passes through the fan and exits through outlet.

Stage 2.
Remaining particles are being captured by the pre-filter.

Stage 1.
Oil mist is being twisted and coarse particles (over 1 micron) are being detached in self-cleaning centrifuge.



Accessories and replaceable cartridges

	6793	MB-MW/W	Wall mounting bracket
	6792	MB-MW/S1	Support bracket
	6795	MW-INLET	Inlet duct for connection of MM filter to the machine chamber or extraction arm (if filter is installed on the side of the machine). Diameters: 2x160mm.
	6791	MB-MW/S2	Mounting adapter for installation of MM filter on the support column sPA.
	6796	CART-2/WRAP	Replaceable filter with bag pre-filter. Filtration surface – 10m ² . Replacement when 1000Pa pressure drop reached.
	6797	MW-WRAP/2	Bag pre-filter for replaceable cartridge CART.
	6059	sPA-110	Support column for installation of extraction arm or MM filter L=1100mm.
	6060	sPA-220	Support column for installation of extraction arm or MM filter L=2200mm.

Recommended installation options

- Installation directly on the CNC machine with closed chambers.
- Installation on the support pole standing next to closed, semi-closed and opened machines.
- Installation on the wall next to closed, semi-closed and opened machines.



RADIAL FANS



VMA, VMK, VMS

Radial fans with steel welded body, made in a shape of snail, and aluminum impeller. Productivity 150 – 5000 m³/h, pressure 1100 – 2450 Pa. Models vary in mounting options: with universal bracket, with support for installation on the floor or with the flange for installation on filters.

page 99



FTEV, FTEVnr

Radial fans with square steel body, assembled without welding, and aluminum impeller. Productivity 500 – 11200 m³/h, pressure 1550 – 4300 Pa. Fans with “nr” index have noise reduction jacket. FTEV-9000/FTEV-1100 and all “nr” fans are delivered with additional rubber-metal vibration isolators.

page 102



HPF

Wide range of radial fans with airflow up to 25000 m³/h, pressure of 2800 to 5400 Pa. Fan body is made of steel, welded in a shape of snail. Impeller is made of powder coated steel, welded. Vibration isolators are not included. All fans of this type have optional noise reduction casing with inspection door.

page 104



HPF-LI/RI

Radial HPF fans, with full size noise reduction casing and inspection door made on the left (LI) or right (RI) side of the fan. This series of fans is delivered with rubber-metal vibration isolators and reinforces flexible inserts inside noise reduction casing.

page 104

VMK, VMA, VMS | INDUSTRIAL FANS

Description

Industrial radial medium pressure fans with steel welded body, made in a shape of snail, productivity up to 5000 m³/h and max. full pressure up to 2450 Pa. These fans are intended for non-explosive environments with temperature from -40°C to +40°C.



Intended use

SovPlym fans are being used for various tasks, where extraction of clean or slightly polluted air is required (dust concentration not more than 0,1g/m³):

- Welding and soldering processes;
- Removal of exhaust gases;
- Removal of oil mist and smoke;
- Removal of non-sticky and non-explosive dust.

Features and advantages

- Light impeller made of alumina
- Precise balancing
- Low vibration level
- Simple installation
- Not requiring frequent maintenance
- Durable design
- Low noise level
- High quality powder coating

Aerodynamic characteristics of VMK, VMA and VMS fans

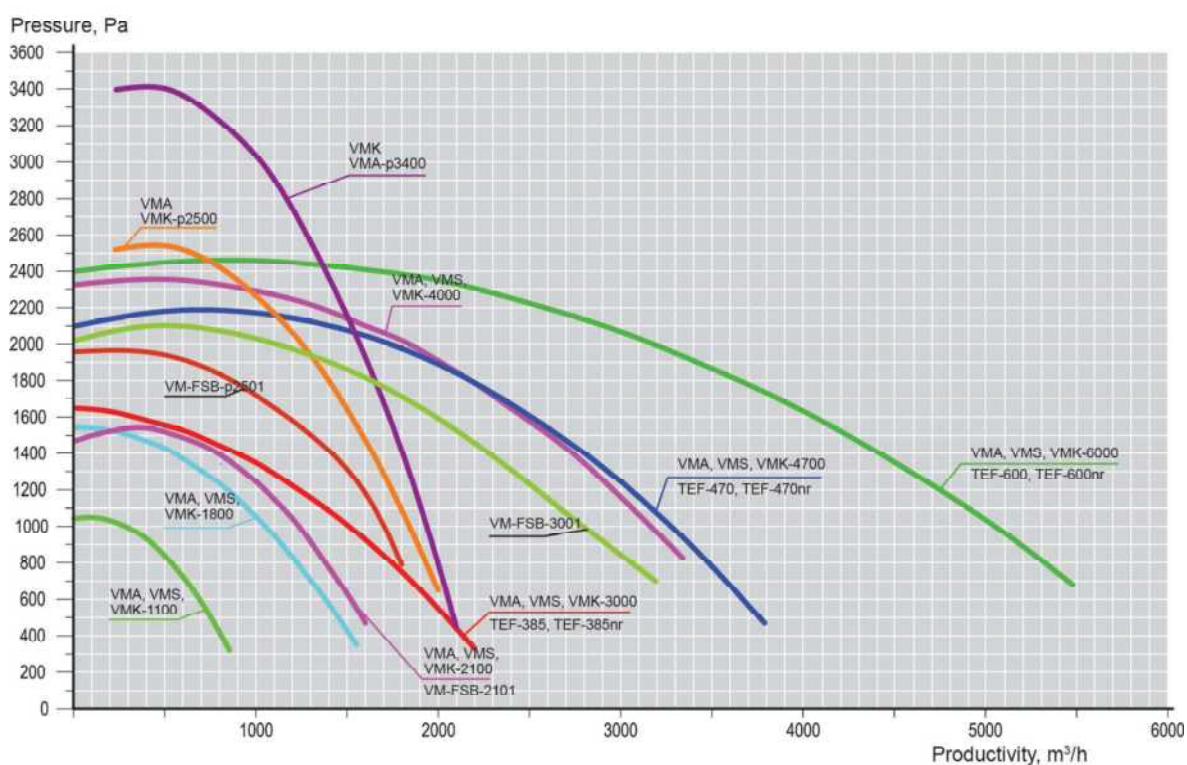

Production range. Major technical characteristics.

Article	Fan model	Optimal working regime		Motor				Weight, kg						
		Pressure range, Pa	Productivity, m ³ /h	Power, kW	Voltage, V	Current frequency, Hz	Rotation speed, rpm							
5784	VMK-1100	1100-400	150-800	0,37	380, 3ph	50	2730	11						
5780	VMA-1100							10						
5786	VMS-1100							15						
5782	VA-1100							10						
5785	VMK-1101				220, 1ph		11							
5781	VMA-1101						10							
5787	VMS-1101						15							
5783	VA-1101						10							
5045	VMK-1800	1500-700	300-1300	0,55	380, 3ph	50	2730	19						
5044	VMA-1800							14,5						
5042	VMS-1800							19						
6041	VA-1800							14,5						
5071	VMK-1801				220, 1ph		21,8							
5072	VMA-1801						17,3							
5043	VMS-1801						21,8							
6041	VA-1801						17,3							
5050	VMK-2100	1550-650	300-1500	0,75	380, 3ph	50	2820	21,6						
5049	VMA-2100							17,1						
5046	VMS-2100							21,6						
6013	VA-2100							17,1						
5073	VMK-2101				220, 1ph		22,5							
5074	VMA-2101						18							
5047	VMS-2101						22,5							
6036	VA-2101						18							
5058	VMK-3000	1550-700	500-1900	1,1	380, 3ph	50	2800	27						
5056	VMA-3000							23						
5051	VMS-3000							27						
5075	VMK-3001							28						
5076	VMA-3001				220, 1ph		24							
5053	VMS-3001						28							
5194	VMK-p2500						2550-1800	400-1400	380, 3ph	2870	25			
5119	VMA-p2500										21			
6061	VA-p2500	23												
5195	VMK-p2501	25												
5120	VMA-p2501	3400-2000	400-1600	220, 1ph	2870	21								
6062	VA-p2501					23								
5087	VMK-p3400					2320-800	800-3400	380, 3ph	2880	35				
5086	VMA-p3400									1,5	800-3400	220, 1ph	2790	31
5728	VMK-4000	2,2	800-3500	380, 3ph	2860									33
5720	VMA-4000													2450-1000
5736	VMS-4000					2,2	800-3500	380, 3ph	2860					
5729	VMK-4001									2,2	800-3500	380, 3ph	2860	
5721	VMA-4001	2,2	800-3500	380, 3ph	2860									
5737	VMS-4001													2,2
5062	VMK-4700					2,2	800-3500	380, 3ph	2860					
5061	VMA-4700									2,2	800-3500	380, 3ph	2860	
5060	VMS-4700	2,2	800-3500	380, 3ph	2860									
5624	VMD-4700													2,2
5266	VMK-6000					2,2	800-3500	380, 3ph	2860					
5269	VMA-6000									2,2	800-3500	380, 3ph	2860	
5268	VMS-6000	2,2	800-3500	380, 3ph	2860									
5625	VMD-6000													2,2

Attention: SovPlym remains the right to alter characteristics and motor models without prior notice.

*VA fans are used with hose reels, see "Vehicle exhaust extraction system" catalogue from SovPlym.

** VMD fans are used for installation on DCSC-S filters.

Production range overview



VMA (VMD)

This series of fans was specially developed for installation directly on filters, manufactured by SovPlym. VMD are intended for vertical installation on top of DCSC-S self-cleaning filters, with special connecting duct piece.



VMS (VMSB)

Fan on special support with handle for carrying. VMSB fan have round outlets and are intended for pressurizing various trampolines and other inflatable constructions.



VMK

This series of fans is supplied with two universal brackets. These brackets allow installation of fan on walls, ceiling, floor and fix the fan body in any position, including parallel or perpendicular to support surface.

FTEV, FTEVnr | INDUSTRIAL FANS



Description

Radial fans of FTEV series provide airflow from 500 to 11200 m³/h at pressure range of 1550 to 4300 Pa. Square body shape allows easy installation on the floor or mounting on the wall, as well as manufacturing of noise reduction jacket for these fans. Working temperature range from -40 to +40°C.

Intended use

FTEV fans are intended for transportation of non-explosive gas mixtures with dust concentration below 0,1g/m³:

- Welding processes;
- Removal of vehicle exhaust gases;
- Removal of oil mist and smoke;
- Removal of non-sticky and non-explosive dust.

Features and advantages

- Light impeller made of alumina
- Precise balancing
- Low vibration level
- Not requiring frequent maintenance
- Low noise level
- Simple installation, square body shape
- Durable welded construction.

Aerodynamic characteristics of FTEV fans

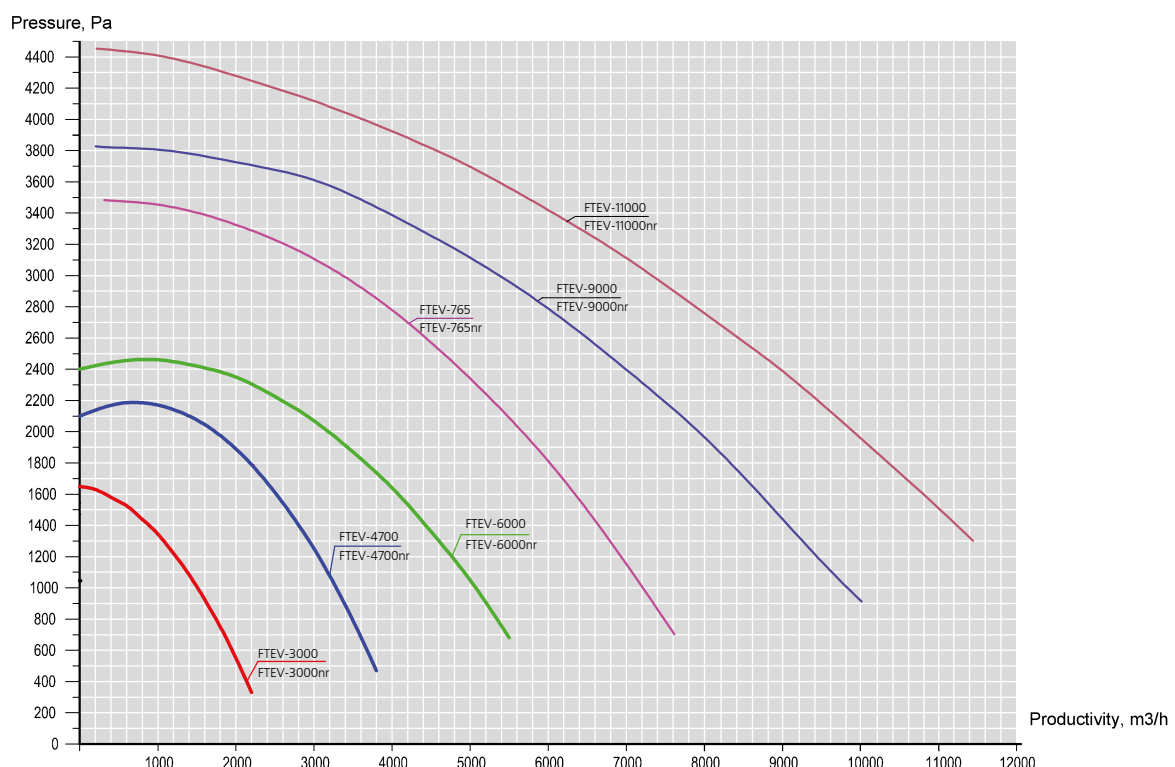





Technical characteristics

Article	Fan model	Optimal working regime		Three phase electrical motor				Weight, kg
		Pressure range, Pa	Productivity, m ³ /h	Power, kW	Voltage, V	Current frequency, Hz	Rotation speed, rpm	
Without noise reduction jacket								
5405	FTEV-385	1550-700	500-1900	1,1	380	50	2810	30
5400	FTEV-470	2200-800	800-3500	2,2	380	50	2860	48
5402	FTEV-600	2450-1000	1000-5000	4,0	380	50	2850	63
5078	FTEV-765	3400-1200	1400-6900	5,5	380	50	2850	80
5180	FTEV-9000	3750-1400	1600-9000	7,5	380	50	2910	150
5191	FTEV-11000	4300-1400	1800-11200	11,0	380	50	2890	185
With noise reduction jacket								
5406	FTEV-385nr	1550-700	500-1900	1,1	380	50	2810	46
5401	FTEV-470nr	2200-800	800-3500	2,2	380	50	2860	75
5403	FTEV-600nr	2450-1000	1000-5000	4,0	380	50	2850	90
5079	FTEV-765nr	3400-1200	1400-6900	5,5	380	50	2850	110
5103	FTEV-9000nr	3750-1400	1600-9000	7,5	380	50	2910	195
5104	FTEV-11000nr	4300-1400	1800-11200	11,0	380	50	2890	255

Accessories

Special accessories are being used for connection of fans, manufactured by SovPlym, to extraction arms and standard ducting systems.

	T250-160-1	T-joint. For connection of one extraction arm or Ø160mm hose to fans with Ø250mm inlets.
	T250-160-2	T-joint. For connection of two extraction arms or Ø160mm hoses to fans with Ø250mm inlets.
	OL	Transition piece for all series of SovPlym fans: VMK, VMA, VMS, VMD, FTEV. Intended for connection of standard rectangular outlet of the fan to round ducts with standard diameters from 100 to 500mm.
	PK	Conical transition piece. Options with various combinations of large (from 100 to 250) and small (from 75 to 200mm) diameters. Intended for connection of hoses or ducts of corresponding diameters to fan, filter and other equipment's inlets.

HPF | INDUSTRIAL FANS



HPF



HPF/LI (RI)

Standard HPF fans

Medium pressure radial fans with snail body shape on the support frame, intended for installation on the floor or any basis. Impeller is welded, made of steel in a shape of squirrel cage.

Optional productivity up to 25000 m³/h, maximum full pressure up to 5 400 Pa, depending on the actual model. Power supply voltage 380 V, 50 Hz.

Standard HPF/LI (RI) fans

This series of fans is supplied in special noise reduction casing. Casing has special inspection door, installed on the left (LI) or on the right (RI) side, relative to the position of the inlet.

Intended use

HPF and HPF/LI (RI) fans are intended for transportation of non-explosive gaseous mixes, which do not cause rapid corrosion of metals (annual corrosion speed below 0,1mm) with contents of dust and other solid admixtures below 0,1g/m³, containing no sticky or fiber materials.

Features and advantages

- Low noise and vibration levels
- Steel, welded impeller
- Precise balancing
- High energy efficiency
- Convenient installation and simple maintenance

Technical characteristics

Model	Optimal working regime		Electrical motor				Inlet diameter, mm	Outlet diameter, mm	Weight, kg	Noise level, dB
	Full pressure, Pa	Productivity, m ³ /h	Power, kW	Voltage, V	Current fr., Hz	Freq., rpm				
HPF-1200	2800–1100	2000–12000	7,5	380	50	2910	450	315x315	113	90
HPF-1200/LI (RI)								Ø 500	247	80
HPF-1500	3500–1200	3000–15000	11	380	50	2890	500	350x350	168	95
HPF-1500/LI (RI)								Ø 630	372	85
HPF-1800	3900–1300	3500–18000	15	380	50	2930	500	350x350	215	95
HPF-1800/LI (RI)								Ø 630	420	85
HPF-2000	4700–1700	4500–20000	22	380	50	2940	560	392x392	280	100
HPF-2000/LI (RI)								Ø 630	488	90
HPF-2500	5400–1800	5000–25000	30	380	50	2940	560	392x392	311	100
HPF-2500/LI (RI)								Ø 630	523	90

IMPORTANT INFORMATION

HPF industrial fans must be equipped with soft start automatics or frequency inverter, which has to be ordered separately. For more detailed information, contact our specialists.

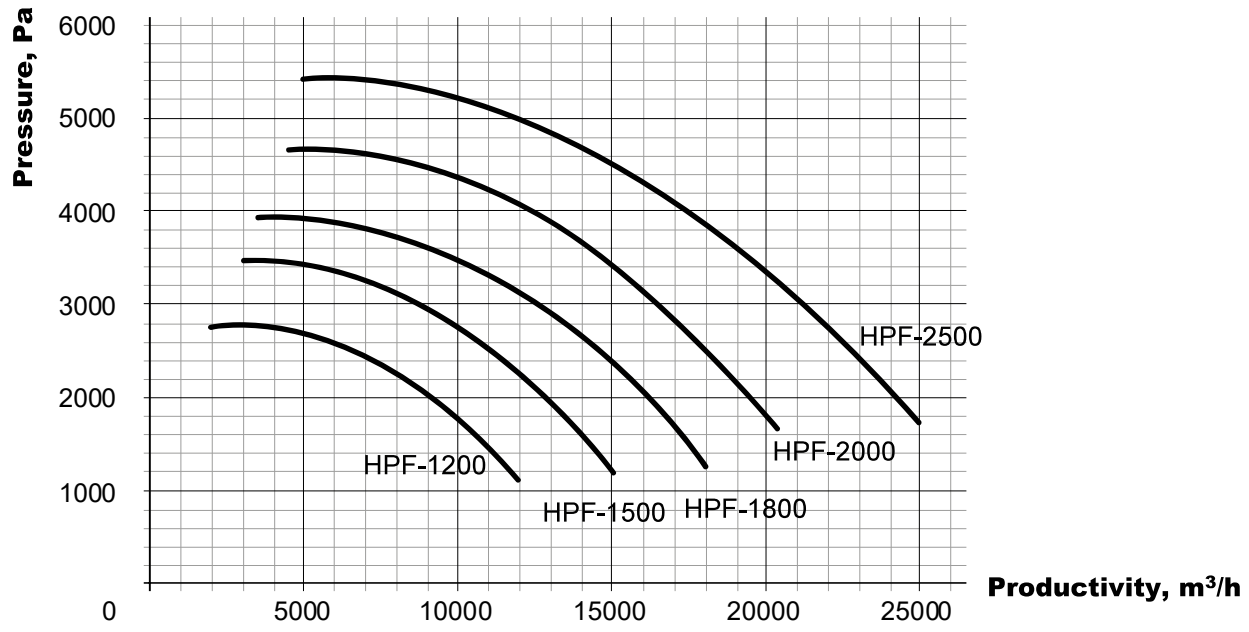
Aerodynamic characteristics of HPF fans



AD

Electrically driven automatic damper



ICE-LC

Automatic damper control box

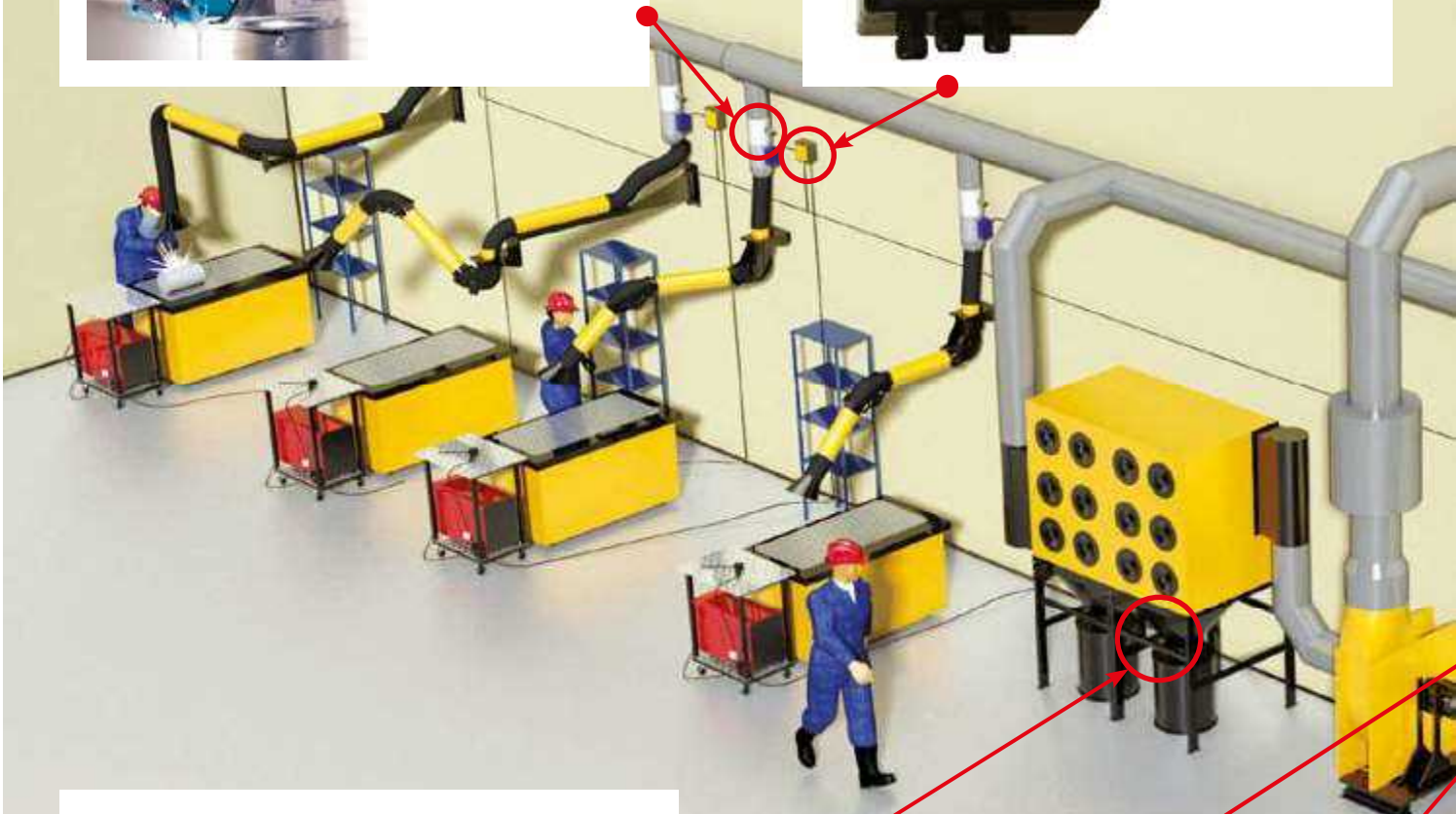

Control boxes CONT

Control box for self-cleaning filters



Frequency inverter

Provides required airflow in the system by adjustment of fan rotation speed according to signal from USS unit.



USS

Signal coordination unit. Sends the signal to frequency inverter depending on the number of activated sensors.



Control box PU for extraction arms

Supplied with starter and thermal relay for the fan motor and transformer for extraction arm lighting lamp.

In order to increase energy efficiency of filtration systems and avoiding human factor influence on their work, SovPlym has developed series of units, which allow fully automatic activation, adjustment (or maintaining) of productivity, deactivation, notification on maintenance requirement or emergency situations.



ES-90, PCU-1000, PU-F

Energy saving control boxes. Fan start/stop is done with the help of sensors (ordered separately).

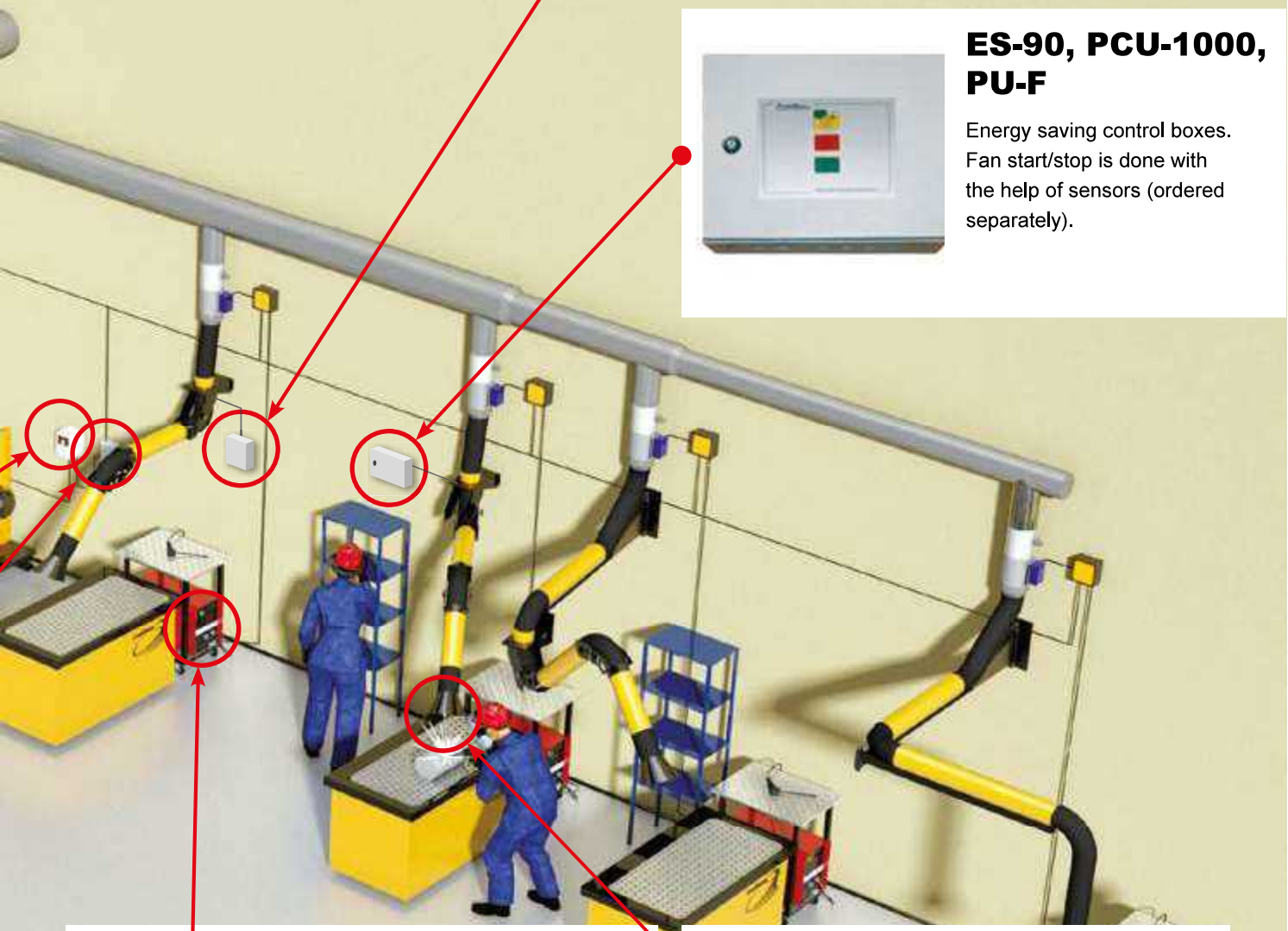

IWS

Induction sensor. To be connected on the ground cable of welding machine. Detects start/stop of the welding process on the basis of current presence.



Light sensor

Lights sensor for extraction arm nozzle. Detects start/stop of the welding process on the presence of light.

AUTOMATIC CONTROL SYSTEMS



IWS

Induction sensor is being fixed on the ground cable of welding machine. Detects start/stop of the welding process by the presence of electrical current. Works in connection to automatic damper control box ICE-LC.



LS-12

Lights sensor is being fixed on the nozzle of extraction arm. Detects start/stop of the welding process on the presence of light. Serves as an alternative to induction sensors for welding currents below 30 A and gas welding processes.



USS

Signal coordination unit send the signal for parameter change of frequency invertor depending on the number of activated induction, light or other sensors. Intended for connection of up to 8 control signals from ICE-LC units.



AD

Electrically driven automatic damper. Available diameters 100, 125, 160, 200, 250, 315, 400mm. Power supply for electrical drive and controls from ICE-LC control box.



Frequency invertor

Provides required airflow in the system by adjusting the rotation speed of the fan motor according to signal from USS.



Control box CONT/SP

Control box for filters with automatic cartridge cleaning system by compressed air. Supplied with controller for up to 32 pneumatic valves. Cartridge cleaning done in accordance to estimated values of compressed air pulse length and frequency.



CONT-M control box

Main control box for filters with automatic cartridge cleaning system by compressed air. Supplied with controller for up to 24 pneumatic valves. Equipped with electronic differential manometer with P-function, activating cartridge cleaning system on the basis of estimated value for cartridge clogging. For more than 24 pneumatic valves, additional control box CONT-S (secondary) is required.



ICE-LC

Control box for automatic damper AD. Damper opening/closing signal comes from induction or light sensor, or button on the nozzle of the extraction arm with lighting.



PU

Controller for extraction arms with lighting. Intended for power supply of lighting lamp and fan starting with the help of buttons, located on the nozzle of extraction arms with lighting. Controller is supplied with transformer for connection of up to 5 pcs of 20W halogen lamps and starter with thermal relay for one fan.



ES-90, PCU-1000

Automatic controllers for energy saving. Intended for systems without automatic adjustment of airflow by frequency inverter. Conduct start/stop of the fan on the signal from induction/light sensor or manually.

TABLES FOR WELDING, GRINDING, THERMAL CUTTING



page 111

Welding-grinding table CCZ-1200

Professional extraction table for removal of dust and fumes from light types of welding and grinding. Pollutant capturing done through exhaust grid, taking full table top surface. Table is equipped with protective screens made of flexible strips. Intended for connection to external filtration system with productivity from 1200 to 2500 m³/h.



page 112

Welding-grinding table CCZ-2500

Professional extraction table for removal of dust and fumes from intensive types of welding and grinding. Pollutant capturing done through table top exhaust grid and vertical suction panel on the back wall. Table is equipped with two hinged protective screens and adjustable legs. Intended for connection to external filtration system with productivity from 2500 to 3000 m³/h.



page 113

Welding table CCB-1200

Basic model of welding table, equipped with integrated fan and self-cleaning filter, with productivity of 1200 m³/h. Supplied with extraction arm. Cartridge cleaning system requires connection to external system of compressed air supply. Optionally available with integrated compressor.



page 115

Welding table CCM-1200

Full set of the welding table with maximum options, equipped with integrated fan and self-cleaning filter with productivity of 1200 m³/h. Supplied with extraction arm, protective screens, luminescent lamp, rotary table and adjustable legs. Cartridge cleaning system requires connection to external system of compressed air supply or compressor. Optionally available with integrated compressor.



page 117

Modular suction table CCT

Sectional suction table to thermal cutting. This table is developed for removal of dust and smoke, formed during plasma, laser, gas cutting of metal. Modular design allows building of required configuration according to the size of the metal sheet. Requires connection to the extraction system with corresponding filter.

CCZ-1200

WELDING-GRINDING TABLE



Description

Professional extraction table for removal of dust and fumes from light types of welding and grinding. Pollutant capturing done through exhaust grid, taking full table top surface. Table is equipped with protective screens made of flexible strips. Intended for connection to external filtration systems from SovPlym.

Intended use

- Welding
- Grinding
- Polishing

Limitations

- Not for thermal cutting of metals.
- Not for aggressive, combustible or explosive substances.
- Not for dust or materials inclined to smoldering or self-igniting.

Features and advantages

- Adjustable feet for installation on uneven surfaces.
- Full table top surface exhaust grid from carbon steel.
- Detachable screen from protective strips.
- Convenient cabinet for tools with lock.
- Integrated lighting.
- Outlets for duct connection on both sides.

Technical characteristics

Article	Dimensions, mm (LxWxH)	Max. load, kg	Table top height, mm	Max. airflow, m ³ /h	Pressure drop, Pa	Connection diameter, mm	Weight, kg
5492	1010x820x1570	100	852	2500	300	200	150

Delivery set

- Protective screen from flexible strips
- Luminescent lamp
- Side ducts Ø 200mm
- Lockable cabinet for tools
- Detachable steel exhaust grid

CCZ-2500

WELDING-GRINDING TABLE



Description

Professional extraction table for removal of dust and fumes from intensive types of welding and grinding. Pollutant capturing done through table top exhaust grid and vertical suction panel on the back wall. Table is equipped with integrated damper for distribution of suction between horizontal and vertical suction surfaces. Supplied with two side hinged protective screens and adjustable legs. Intended for connection to external filtration system from SovPlym.

Intended use

- Intensive welding processes.
- Intensive metal processing (sample: welding seam processing with corner-grinding machines).

Limitations

- Not for thermal cutting of metals.
- Not for aggressive, combustible or explosive substances.
- Not for dust or materials inclined to smoldering or self-igniting.

Features and advantages

- Adjustable feet for installation on uneven surfaces.
- Full table top surface exhaust grid from carbon steel.
- Vertical extraction panel.
- Side hinged metal screens.
- Convenient cabinet for tools with lock.
- Integrated lighting.
- Outlets for duct connection (two on both sides and one on the top).

Technical characteristics

Article	Dimensions, mm (LxWxH)	Max. load, kg	Table top height, mm	Max. airflow, m ³ /h	Pressure drop, Pa	Connection diameter, mm	Weight, kg
5479	1125x866x1825	100	833	3000	200	250	153

Delivery set

- Side protective screens
- Luminescent lamp
- Connection ducts Ø250mm, 3 pcs.
- Lockable cabinet for tools
- Detachable steel exhaust grid

CCB-1200 | WELDING TABLE



Description

Basic welding table CCB-1200 with integrated fan and self-cleaning filter, with productivity of 1200 m³/h. CCB-1200 is intended for removal and filtration of welding fumes and aerosols from various types of welding. Capturing of smokes is done through extraction grid in the table top and extraction arms. Cartridge cleaning system requires connection to external system of compressed air supply. Optionally available with integrated compressor.

Intended use

Designed for various industrial factories, training and certification facilities.

Limitation

- Not for thermal cutting of metals.
- Not for explosive, combustible or aggressive substances.

Features and advantages

- Integrated silencer.
- Solid metal work surface with integrated alumina grid.
- Integrated self-cleaning filter.
- Integrated compressor (option).

Technical characteristics

Dimensions, mm (LxWxH)	Max. load, kg	Table top height, mm	Max. airflow, m ³ /h	Power consumption (380 V), kW	Integrated fan	Filtration surface, m ²	Noise level, dB	Weight, kg
1600x885x815	100	815	1200	1,1	F-p2500	12	70	200

Optional types

Article	Model	Filter type
Without compressor		
27863	CCB-1200-T12	CART-T12
With integrated compressor		
27873	CCB-1200-K-T12	CART-T12

Delivery set

- Integrated fan
- Filtration cartridge
- Extraction arm
- Oil and moisture separator with reducer and manometer
- Control box

Filtration cartridges

	Article	Model	Description
	6903	CART-T12	Filtration cartridge, 12m ² , PTFE



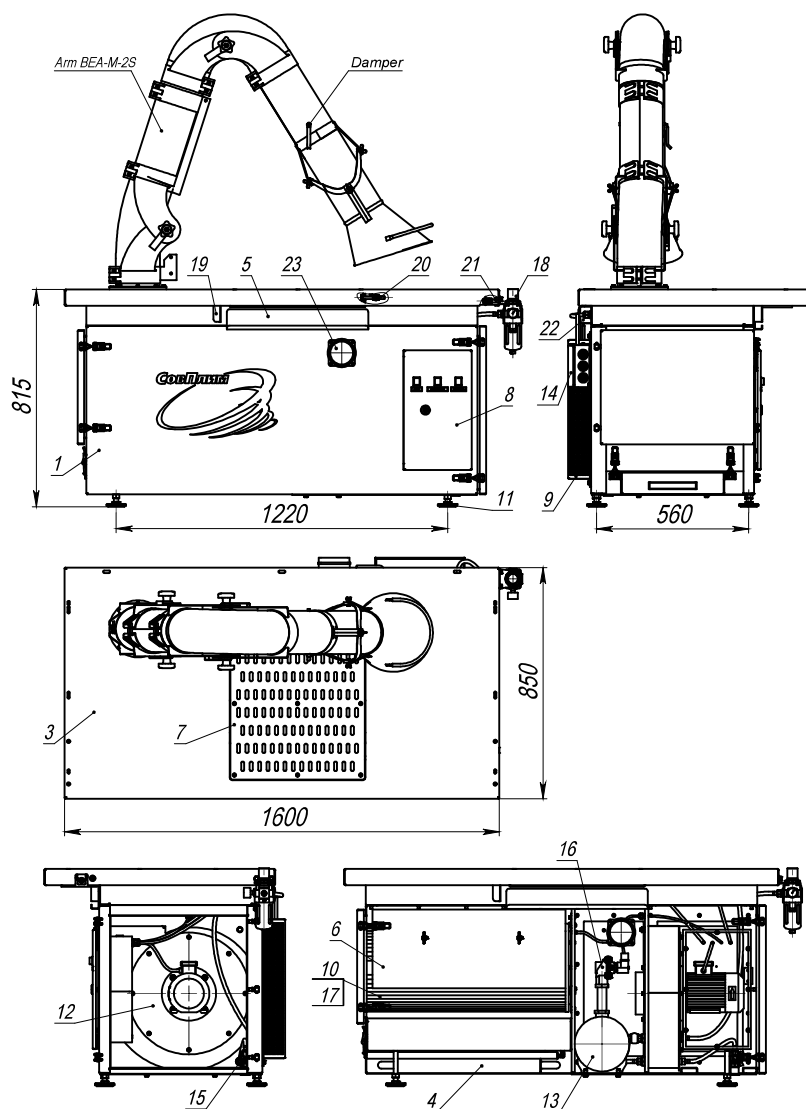

Dimensions



1. Table body;
2. Frame;
3. Table top;
4. Dust bin;
5. Tray for slag;
6. Spark-arrestor;
7. Grid;
8. Control box;
9. Silencer;
10. Splitter;
11. Adjustable feet;
12. Integrated fan;
13. Receiver;
14. Connector;
15. Ball valve;
16. Electromagnetic valve with timer;
17. Filtration cartridges CART;
18. Oil and moisture separator (CCB/CCM-1200);
19. Regulating damper;
20. Threaded pin M8 "mass";
21. Threaded pin M10 "grounding";
22. Single phase socket 220 V;
23. Integrated differential manometer;
24. Air compressor *

*only for CCB-1200-K/CCM-1200-K

Additional equipment

	Артикул №	Модель	Описание
	6382	OZM	Metal protective screen. Consists of back and two side steel walls. Side walls can be opened or detached.
	6383	OZG	Protective screen made of flexible strips of dark green color fixed on metal frame. Strips protect from welding radiation as well as sparks and splashes.
	6380	OR-OZ	Luminescent lamp with bracket for installation on protective screen.
	6294	SP	Rotary table for work with small parts. Diameter of rotary part 300mm. Table basis 300x300mm.

CCM-1200

WELDING TABLE



Description

Welding table CCM-1200 with integrated fan and self-cleaning filter with productivity of 1200 m³/h. CCM-1200 is designed for removal and filtration of welding fumes and grinding and polishing dust. Capturing done through extraction grid in the table top and extraction arm. Supplied detachable steel protective screens, luminescent lamp, rotary table and adjustable legs. Cartridge cleaning system requires connection to external system of compressed air supply or compressor.

Intended use

Designed for various industrial factories, training and certification facilities.

Limitation

- Not for thermal cutting of metals.
- Not for explosive, combustible or aggressive substances.

Features and advantages

- Integrated silencer.
- Massive steel table top with aluminum extraction grid.
- Integrated fan and self-cleaning filter.
- Detachable screens allow working with large constructions.
- Equipped with rotary table for welding small parts.

Technical characteristics

Dimensions, mm (LxWxH)	Max. load, kg	Table top height, mm	Max. airflow, m ³ /h	Power consumption (380 V), kW	Integrated fan	Filtration surface, m ²	Noise level, dB	Weight, kg
1600x885x1315	100	815	1200	1,1	F-p2500	12	70	200

Optional types

Article	Model	Filter type
27843	SSM-1200-T12	CART-T12

Delivery set

- Integrated fan
- Filtration cartridge
- Extraction arm
- Oil and moisture separator with reducer and manometer
- Control box
- Rotary table
- Lighting

Filtration cartridges

	Article	Model	Description
	6903	CART-T12	Filtration cartridge, 12m ² , PTFE

Dimensions

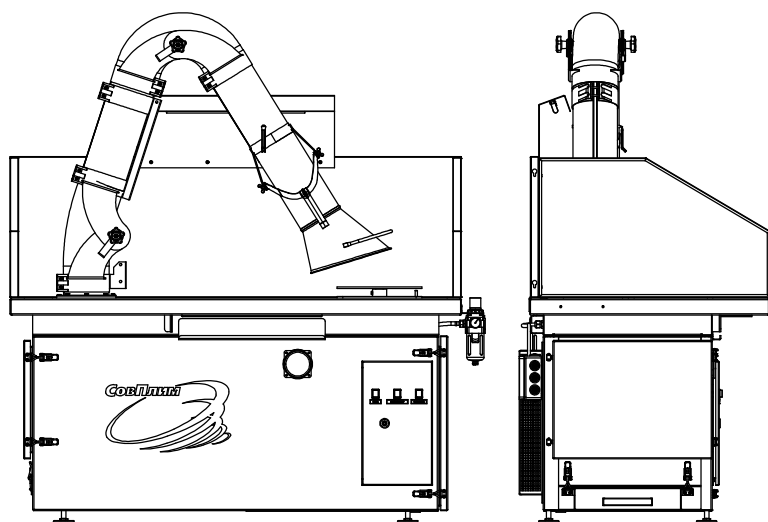

Dimensions of welding table CCM-1200 with integrated fan and self-cleaning filter are similar to the dimensions of basic welding table CCB-1200 with integrated fan and self-cleaning filter (page 114).

CCT

TABLE FOR THERMAL CUTTING OF SHEET METAL



Description, area of use, limitations

Sectional extraction table, manufacture by SovPlym is intended for thermal cutting of sheet metal with portal machines of various manufacturers and removal of products of burning formed during cutting.

Extraction table has modular design and is assembled from standard extraction sections of CCT series. CCT modules have various lengths and widths, allowing building of the table with required dimensions.

Removal and cleaning of air from pollutants is provided by filtration installation, which should be chosen and ordered separately, depending on the size of the table and number of cutting parameters.

Surrounding environment and air, containing products of burning, should not be explosive or/and containing aggressive vapors and gases.

Features and advantages

- Removal of smoke directly from cutting zone.
- Smallest volume of extracted air at maximum efficiency of smoke removal.
- Significant reducing of cost, energy consumption and dimensions of filtration unit.
- Pneumatic components from Japanese supplier "SMC".
- Pneumatic cylinders do not require periodical greasing.
- Resource of pneumatic cylinders over 8000km (50 mln cycles).
- Modular design for simple transportation and maintenance.
- Standard modules allow building large number of optional table sizes.

Design and working principle

Table consists of several modules, installed in a row one after another. Number of modules depend of the length of the working zone. Two rows can be installed next to each other to receive table of necessary width.

Standard module has three optional widths: 1500, 2000, 2500mm and two optional lengths: 1500 or 2000mm. Each module has side air channel for smoke removal. Thus standard modules allow building a table of up to 18 m and more in length and up to 4m wide. Tables over 2,5m wide will have two air channels, since it is build of two rows of modules.

General view of table,
assembled from CCT
modules:

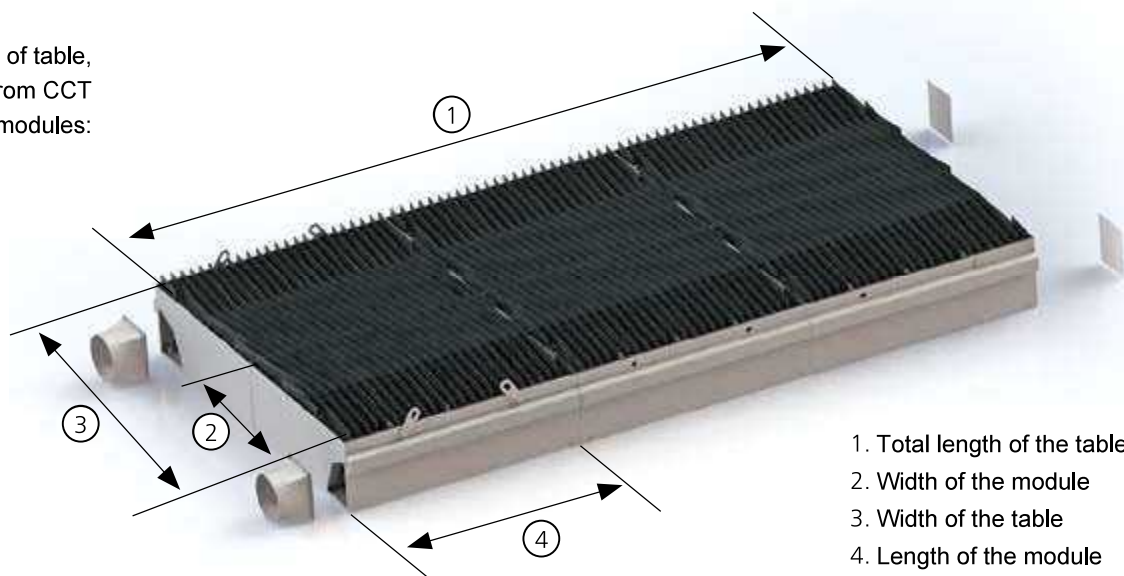

1. Total length of the table
2. Width of the module
3. Width of the table
4. Length of the module

Design of single module of extraction table

Module of extraction table consists of following basic elements:



1. Main frame with plates
2. Mesh for small parts
3. Bath for slag
4. Table module

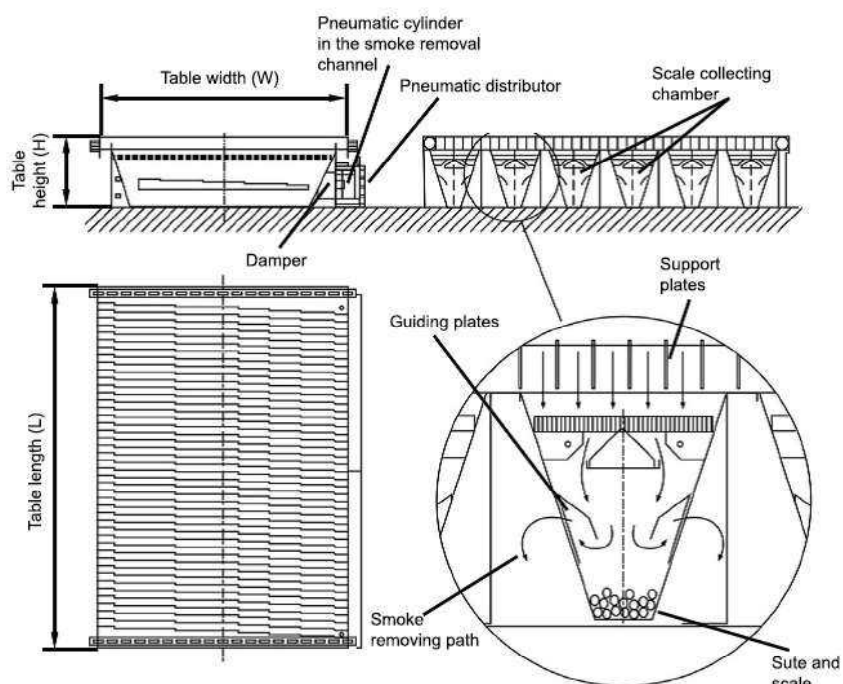

Body of the module is welded metal structure. It is separated into 4 sections (CCT15x20, CCT20x20, CCT25x20) or 3 sections (CCT15x15, CCT20x15, CCT25x15), each 515mm wide separated from each other.

Each section of CCT has a bath installed for collection of solid particles, formed during thermal cutting process. Bath is made in a way, forming ring suction zone, providing even suction of smoke in every point of section. On top of the bath there is a net, preventing small parts falling down into the bath. Nominal size of openings in the net is 40mm.

Top part of the module is made of plates, installed vertically in special slots. Plates serve for placing the sheet of metal which is being cut. Plates are made of straight cut metal strips, allowing local manufacturing of replaceable plates in future.

Module has special air channel with windows opposite to each section. These windows are closed with dampers, placed on pneumatic cylinder rod, which are being controlled with special pneumatic distributing device, fixed on the front wall of the section body and covered with protective hood. In order to provide high reliability, we use Japanese components for pneumatic system from SMC company.



For ease of installation, the table is equipped with special eyelets. Due to the fact that they are removable, it is possible to install the modules one by one using just one set of eyelets.

The number of modules depends on the size of the working area. The modules are connected to each other using sets of mounting and connecting parts, which are ordered separately. Modules, arranged in one row, form an air duct for removal of fumes and gases. One end of this channel is closed with a special plug, and the other is equipped with a transition piece for connection to Ø400 mm duct. When the working area is over 2.5 meters wide, the modules are assembled in two rows. In this case, the table will have two air ducts with Ø400 mm adapters for connection to the extraction system.

In general, the work of the table is as follows. In the process of cutting, the burner of the cutting machine moves relative to the blank lying motionless on the plates. The thermal cutting machine is equipped with a control lever, which is included in the assembly kit.

When the burner moves along the table, the lever deflects the roller alternately for each of the pneumatic distributors. As a result, pneumatic cylinders opens and closes flaps of the air channel windows one after another. Thus, only one flap is open at a time, opposite to the section over which the cutting is currently taking place. When the damper is open, the cutting products are being removed from the section. This method has an advantage over simultaneous suction from the entire surface of the table, since, due to the division into small sections of 0.5 meters each, a significantly lower air consumption of the filtration equipment is required. Reducing the performance and power of filtration unit allows reduction of energy consumption, number and cost of replacement cartridges, space occupied by filtration system, noise level.

Technical characteristics

Module model *	CCT 15x20	CCT 15x15	CCT 20x20	CCT 20x15	CCT 25x20	CCT 25x15
Table dimensions (without pneumatic system), mm, LxWxH	2063x1634x690	1548x1634x690	2063x2134x690	1548x2134x690	2063x2634x690	1548x2634x690
Dimensions of the metal sheet to cut, mm, LxW	2000 x 1500	1500 x 1500	2000 x 2000	1500 x 2000	2500 x 2000	2500 x 1500
Maximum load per module, kg/m ²	785					
Pressure of compressed air (working), MPa	0,4-0,5 (4-5)					
Diameter of connected duct	400					
Max. weight, kg	630	480	790	610	920	750
Max. temperature of gases removed, °C	120					
Consumption of compressed air per opening/closing, liters of free air	2,4					

* in the name of the model, first digit shows width of the metal sheet to be cut, second – shows the length of the sheet (15 – stands for 1500mm, 20 – for 2000mm)

Recommendations on selection of CCT modules

Width of the metal sheet to be cut, mm	1500	2000	2500	3000	4000
Configuration of CCT modules	1 row	1 row	1 row	2 rows	2 rows
Model of CCT modules (number of modules in 1 row is determined by the length of the sheet)	CCT15x15 or CCT15x20	CCT20x15 or CCT20x20	CCT25x15 or CCT25x20	CCT15x15 -2pcs or CCT15x20 -2pcs	CCT20x15-2pcs or CCT20x20-2pcs
Number of connection ducts to filtration system	1	1	1	2	2
*Airflow, m ³ /h (for tables up to 18m long)	3600	4800	6000	7800	9600
*Airflow, m ³ /h (for tables over 18m long)	–	6000	7800	9600	11200
Number of connecting kits KC	N _{KC} = N CCT modules – 1			N _{KC} = (N CCT modules – 1)x2	
Number of installation kits KM	1			2	

* Airflow stated in the table is for the reference purpose only and calculated for portal machines with single burner and plasma source up to 300A.

In any case, when determining the configuration of extraction table, airflow and type of filtration installation should be coordinated with SovPlym specialists.

List of components for table assembly

	Model	Technical characteristics. Delivery set.
	CCT 15x20	Sectional extraction module for thermal cutting of metal 1500x2000mm (WxL).
	CCT 15x15	Sectional extraction module for thermal cutting of metal 1500x1500mm (WxL).
	CCT 20x15	Sectional extraction module for thermal cutting of metal 2000x1500mm (WxL).
	CCT 20x20	Sectional extraction module for thermal cutting of metal 2000x2000mm (WxL).
	KC	Connection kit for thermal cutting table. Sample of calculations: Number of KC = Number of CCT – 1
	KM	Installation kit for thermal cutting table. Note: one row table requires 1 KM kit. Two row tables require 2 KM kits.

General view of the installation of the sectional thermal cutting table

General view of the extraction sectional table for thermal cutting of metals looks like it is shown on the picture (table for cutting the sheet metal 1500mm wide and 3000mm long).

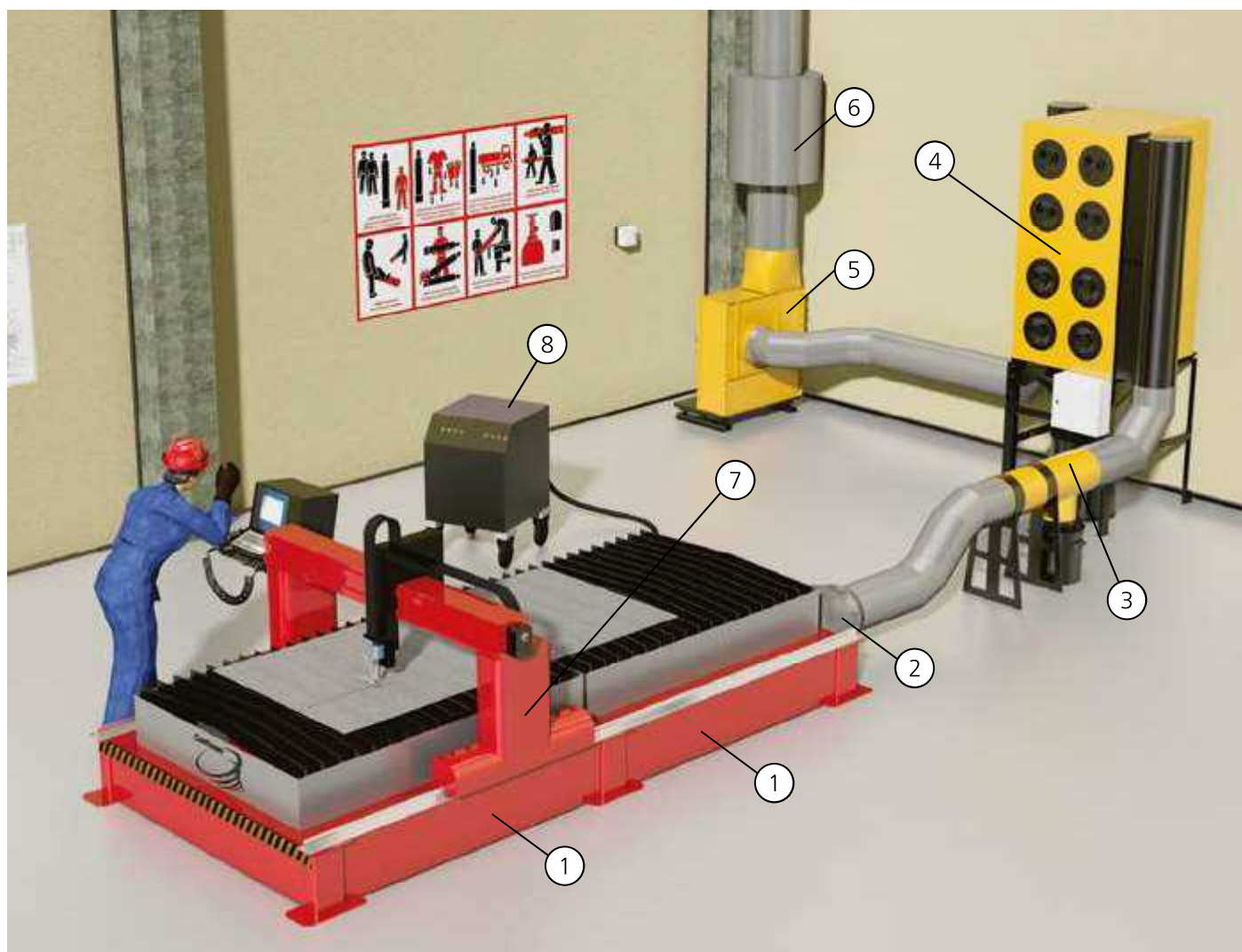

1. Sectional extraction module CCT15x15 – 2 pcs.
2. Connection duct for filtration system
3. Direct flow cyclone for coarse particles capturing
4. Filtration system on the basis of self-cleaning filter DCSC-S-8-T12 with PTFE cartridges.
5. Fan in noise reduction casing.
6. Silencer.
7. Portal machine.
8. Power source.

Calculation of ventilation system

PRESSURE LOSS. CALCULATION OF PRESSURE LOSS IN THE SYSTEM.

Pressure loss – is the biggest problem in all ventilation systems. On these pages you will find the information on how it occurs, how to calculate it and how to minimize pressure loss in your ventilation system. Remember that no local extraction device will work efficiently if pressure losses in your system are too big.

WHAT IS THE PRESSURE LOSS?

Air resistance in the duct network is mostly determined by the speed of air movement in it. As speed increases, resistance increases as well. This is what's called "pressure loss". Characteristics of "static pressure" of the fan determines the amount of air, which fan can provide at certain value of pressure loss. The higher the pressure loss is, the smaller is the amount of air that fan can deliver.

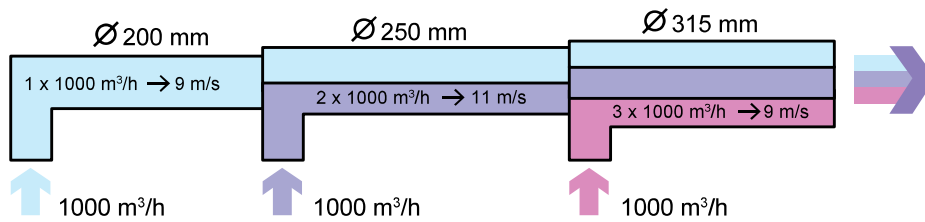

The diagram above shows how pressure loss (resistance) can be minimized by increasing the duct diameter in order to maintain same speed of the airflow along the full length of the system. For smoke and dust removal systems, maintaining the speed of the airflow is very important in order to avoid settling and accumulating of pollutants in the system. Recommended speed of air in extraction system is 9-15m/s.

PRESSURE LOSS CALCULATION

Pressure is measured in pascals (Pa). In order to calculate how many pascals you loose in certain duct, first of all it is necessary to determine how much air passes through this duct. Volume of air per time unit is measured in m³/h or l/s. Information below will give you general understanding on pressure loss calculation.

Correspondence:

1 m³/h = 0,28 l/s

Recommended values:

Speed in the duct: 10-15m/s
Airflow per standard extraction arm
Ø160mm – 1000m³/h

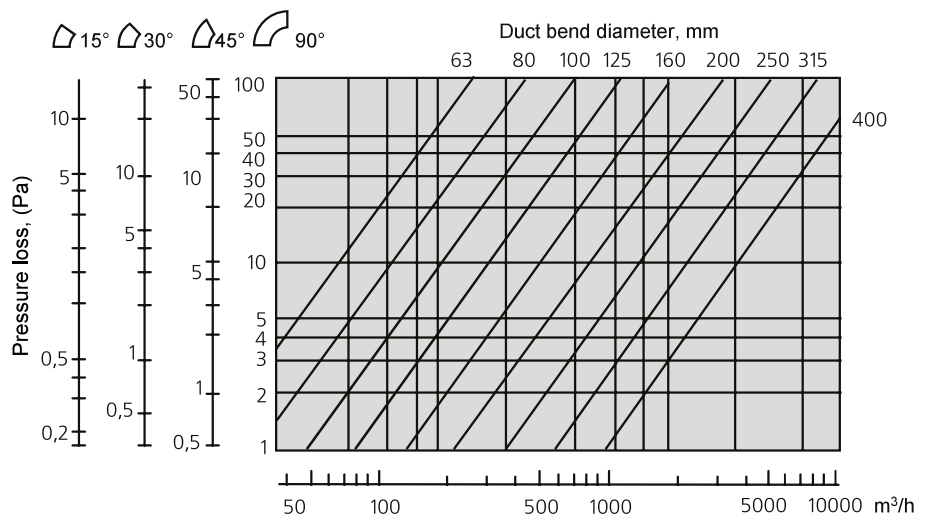

SAMPLE OF CORRECT SYSTEM ORGANIZATION

In large systems, it is preferable to put extraction fan in the middle of the system. It allows minimizing pressure losses and using of less diameter ducts.

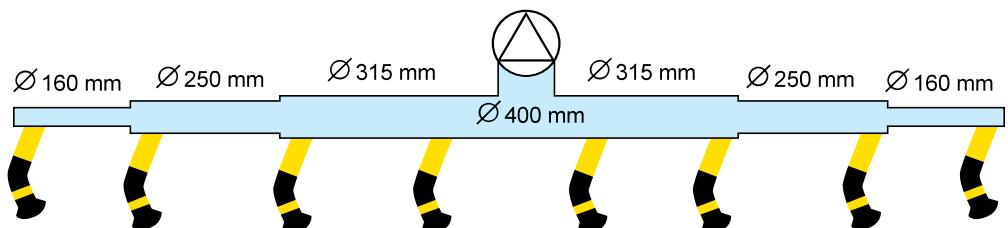

PRESSURE LOSS CALCULATIONS

Duct diameter	1000 m ³ /h		2000 m ³ /h		3000 m ³ /h		4000 m ³ /h		5000 m ³ /h		6000 m ³ /h		7000 m ³ /h		8000 m ³ /h		9000 m ³ /h		10000 m ³ /h		
	Pa	m/s	Pa	m/s	Pa	m/s	Pa	m/s	Pa	m/s	Pa	m/s	Pa	m/s	Pa	m/s	Pa	m/s	Pa	m/s	
Ø 160	18	13	60	26																	
Ø 200	5	9	20	18	45	26	75	35													
Ø 250	2	5,5	6	11	14	17	22	22	40	28	50	34	70	39							
Ø 315			2	6,5	3	9	6	13	9	16	11	19	17	22	22	26	27	28	32		
Ø 400					1	7	2	9	3	11	5	12	6	15	8	17	10	18	12	22	
Ø 500							1	6	1	7	2	8	2	10	3	11	3	13	4	14	

In the table there are pressure losses in Pa per 1 m of ducts of various diameters at various speed of air and airflow.

Step-by-step example of calculation:

1. Start with a simple sketch of the system: where to place extraction arms and fan. What length of ducts will be in between (see pic. 1).
2. Determine necessary airflow in each part of the system (recommended airflow – 1000m³/h per extraction arm) (see pic.2)
3. Calculate pressure loss in the duct for each section (A, B, C and D)

Section A:

Determine duct diameter for section A using the table above: recommended speed of air – 10-15m/s. For the airflow of 1000m³/h duct diameter should be 160mm. Speed of air in it will be equal to 13m/s, pressure losses per 1m will be 18 Pa, which is 18 x 5 for the full section. Result of calculations for section A: 1000m³/h, 160mm, 13m/s, 18x5=90 Pa.

Section B:

Repeat calculations for section B, considering, that this time airflow in the duct should be equal to 2000 m³/h. Result for section B: 2000 m³/h, 250mm, 11m/s, 6 Pa x 5 = 30 Pa.

Section C:

Calculation for section C is more complicated. In the column for 3000 m³/h there is no value corresponding to 10-15m/s. Only for 9 or for 17. Your decision should be based on the speed which you plan to maintain in whole system. Remember that you should maintain even airflow in the system. If you choose 17 m/s, you will get 15 Pa, and at 9 m/s it will be only 3 Pa. Thus 9m/s value will be better choice in this case.

Result for section C: 3000 m³/h, 315mm, 9m/s, 3 Pa x (5 + 5) = 30 Pa.

Section D:

Result for section D: 4000 m³/h, 315mm, 13 m/s, 6 Pa x 5 = 30 Pa.

4. After calculation of pressure losses for the last section, you need to calculate pressure loss for 90 bend. Duct bends have the same diameter as ducts, thus airflow through 315mm bend will be equal to 3000 m³/h. On the table of pressure losses in duct bend find the 3000 value on the bottom scale. Then find the point on diagonal line, corresponding to 315mm, and on the vertical scale find the pressure loss, corresponding to 90 bend. Result for our system is equal approximately to 17 Pa (see pic. 4). Thus for all sections and one bend pressure loss will be equal to: 90 Pa + 30 Pa + 30 Pa + 30 Pa + 17 Pa = 197 Pa. This value should be added by the pressure loss on extraction arm, which is installed at the largest distance form extraction fan. Let's assume that this extraction arm is EF-M-2520, which pressure loss at 1000 m³/h (in medium working position) is equal to 850 Pa. Thus total pressure loss for the system will be equal to 197 + 850 = 1047 Pa. For extraction arms located closer to the fan pressure loss will be smaller, therefore it is recommended to install regulating dampers at each of those. After installation of the system, regulating dampers should be adjusted to reach equal airflow through each extraction arm.

System calculation is done. You provided even airflow along the whole length of the system and you know that required fan should deliver airflow of 4000 m³/h at pressure loss of 1047 Pa.

HOW TO SELECT A FAN?

Choose the fan which can provide airflow of 4000 m³/h at resistance of the network equal to 1047 Pa. In our case, best suitable fan is F-6000 (see aerodynamic characteristics in "Fans" section), which provides 1600 Pa pressure at 4000 m³/h airflow. It is required for additional installation of regulating dampers, and overcoming of additional pressure drop when extraction arms are folded more than usual. However, even without this assumptions, real airflow through one extraction arm will not be more than 1200 m³/h, which completely corresponds to recommended values. Remember, that in case of installation of the silencer after the fan or long ducting network and other network elements, their additional resistance should also be considered when calculating total pressure losses and choosing the fan.

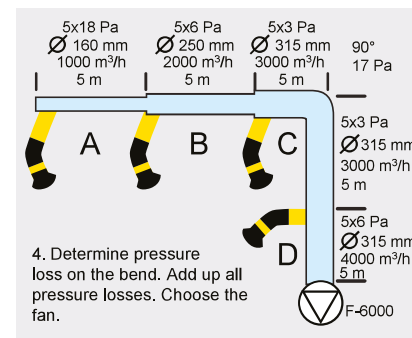
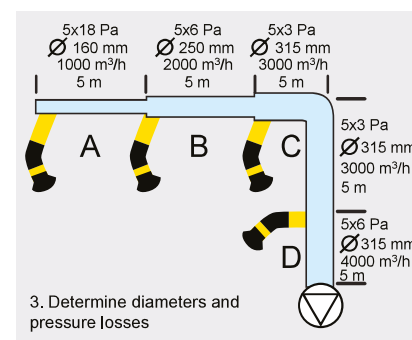
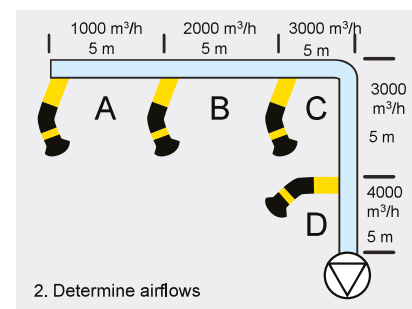
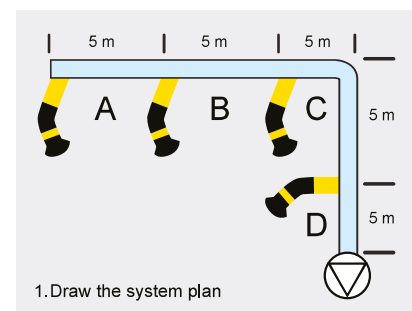

Questionnaire for designing of local extraction ventilation system on welding manufacturing

1. Contact data.

Company name:	Phone:
Contact person:	E-mail:
Company address:	
Name of the workshop:	

2. Task statement:

<input type="checkbox"/> Choice of equipment for replacement in existing ventilation system		
<input type="checkbox"/> Choice of equipment for ventilation system with discharge of clean air to atmosphere		
<input type="checkbox"/> Choice of equipment for ventilation system with return of clean air back into premises		
<input type="checkbox"/> Choice of "Push-Pull" system		
<input type="checkbox"/> Choice of "Diluter" system		
<input type="checkbox"/> Project development	<input type="checkbox"/> Project and design of the system	
<input type="checkbox"/> Installation	<input type="checkbox"/> Installation guidance	<input type="checkbox"/> Start-up
<input type="checkbox"/> Additional requirements		

3. Parameters of technological processes.

Type of welding:	Semi-automatic	Manual	Automatic or other
Number of workplaces			
Type of welding material			
Consumption of welding material, kg/h			
Type of welded metal			
Welding current, A			
Number of welders working simultaneously			
Number of shifts (1 / 2 / 3)			
Pollutants on metal	<input type="checkbox"/> None <input type="checkbox"/> Others	<input type="checkbox"/> Protective greasing	<input type="checkbox"/> Paint
Max. height of welding over the floor level			
Power supply voltage in the workshop, V	<input type="checkbox"/> 220	<input type="checkbox"/> 400	<input type="checkbox"/> Other
Compressed air if present	<input type="checkbox"/> 5-6 bar, 2-3 class according to ISO 8573-1 <input type="checkbox"/> Other		

4. Parameters of premises.

Workshop dimensions, m	(length * width * height)
Cranes and height of guiding rails installation	
Possible height of duct installation, m	

5. Parameters of welded parts.

Type of objects	
Maximum dimensions of welded objects	
Welding conditions	<input type="checkbox"/> Inside the object <input type="checkbox"/> Outside of the object

6. In case of existing ventilation system

General ventilation	Supply	Extraction
Type of installation, fan, number of fans (pcs)		
Productivity, m ³ /h		
Power, kW		

Local extraction ventilation	
Technological equipment *	
Type of fans, quantity	
Productivity, m ³ /h	
Power, kW	

* in case of several items, state data for each item separately

7. Existing heating system

Type of heating system	<input type="checkbox"/> Radiators		<input type="checkbox"/> Air heating	
	<input type="checkbox"/> Heating registrars		<input type="checkbox"/> Infrared heating	
	<input type="checkbox"/> Other			
Type of heat carrier	<input type="checkbox"/> Water	<input type="checkbox"/> Vapor	<input type="checkbox"/> Electricity	<input type="checkbox"/> Gas
Quantity, pcs				
Productivity, m ³ /h				
Power consumption, kW				

Please attach workshop plan or scheme to the present questionnaire with following data:

- type of premises on explosion and fire danger of industrial processes
- positioning of welding work places
- preferable places of installation of extraction arms, ducts, filters and fans (according to the technical assignment)
- in case of air heating, show places of installation of heaters

Questionnaire for filter selection for dust processes

1. Contact data.

Company name:	Phone:
Contact person:	E-mail:
Company address:	
Name of the workshop:	

3. Parameters of technological process

Brief description of technological process, working regime:			
Chemical contents of dust, substances:			
Size of particles:			
Dust properties:	<input type="checkbox"/> Flammable	<input type="checkbox"/> Explosive	<input type="checkbox"/> Sticky
	<input type="checkbox"/> Hygroscopic	<input type="checkbox"/> Abrasive	<input type="checkbox"/> Electrostatic
	<input type="checkbox"/> Moist	<input type="checkbox"/> Corrosion aggressive	
	<input type="checkbox"/> Other		
Bulk density of dust, t/m ³ :			
Temperature of cleaned airflow, C:			
Humidity of cleaned airflow, %:			
Quantity of dust, g/h:			
Size of dust allocation area, m:	(Length * Width * Height)		
Dust concentration at entrance to the filter, g/m ³ :			
Required remaining concentration of dust after filter, mg/m ³ :			

4. Parameters of filter installation location

Filter placement	<input type="checkbox"/> Inside heated premises
	<input type="checkbox"/> Inside non-heated premises
	<input type="checkbox"/> Outside
Explosive and fire danger grade of the premises of industrial process:	
Temperature of the environment, C:	
Required productivity, m ³ /h:	
Presence of compressed air:	<input type="checkbox"/> 5-6 bar, 2-3 class according to ISO 8573-1
	<input type="checkbox"/> Other
Air after filtration	<input type="checkbox"/> Return to premises <input type="checkbox"/> Discharge to atmosphere

5. Additional information

--

Please, attach construction plan with placement of technological equipment and stationary constructions of the building.

○ Branches

● Dealers

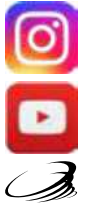

JSC «SovPlym»

Russia 195279
Saint Petersburg
Shosse Revolyutsii 102/2
tel.: +7 (812) 416-40-16
e-mail: export@sovplym.com
www.sovplym.com

SovPlym-India Pvt Ltd

India 411014
Pune
Kharadi, Kolte Patil Downtown
Arrisa Avenue, Unit #15,
Office No. 303
tel.: +91 7875657764
e-mail: info@sovplym.in
www.sovplym.in

SovPlym-Israel Ltd

Israel
Or Akiva
Ha'hadas 2 street
tel.: 1-700-555-846
e-mail: info@sovplym.co.il
www.sovplym.co.il

www.sovplym.com