

Thermal cutting

MAIN PROBLEM:



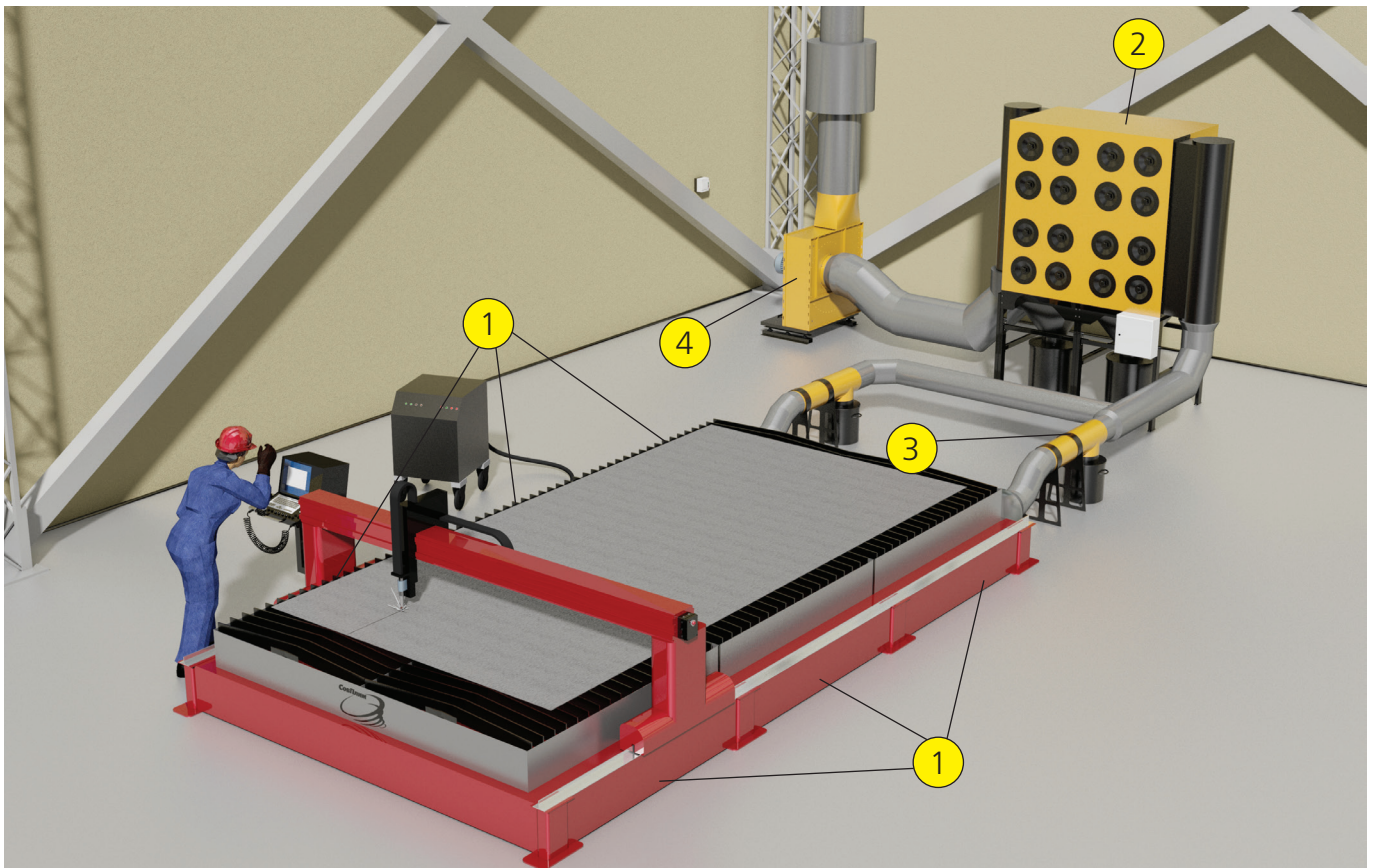

Large amount of smoke in the cutting zone.
The task is capturing of the smoke and cleaning the air. Cutting of wide sheets of metal (up to 3x6m).

SOLUTION:

Sectional exhaust table made of standard modules 1,5x2m put in two rows with two side extraction along the table length. Air filtration via stationary 16 cartridge mechanical filter. Cyclones used as pre-separators for coarse dust.



EQUIPMENT USED FOR SOLUTION:

Equipm.	Pos. on pic.	Description	Pcs
	①	Sectional exhaust CCT 15x20 table for thermal cutting consisting of several modules and intended for placing the sheet metal and removing of the combustion products allocated during thermal cutting.	6
	②	Stationary self-cleaning filter DCSC-S-16-T12 designed to clean the air from dust particles; welding, plasma, laser, gas cutting aerosols and similar particles released during various manufacturing processes in industrial shops.	1
	③	Direct flow cyclones CPO-4000 are being used for cleaning dusty environments from medium - coarse dust. Cyclone design provides its installation (inset) directly into the duct through which, the polluted air is moving.	2
	④	High pressure fan TEF-9000 .	1